

SULIT

UNIVERSITI MALAYSIA PERLIS

Peperiksaan Akhir Semester Pertama
Sidang Akademik 2025/2026

Januari - Februari 2026

EMK32003 – Electrical Machines Technology II
[Teknologi Mesin Elektrik II]

Masa: 2 jam

Please make sure that this question paper has **EIGHT (8)** printed pages including this front page before you start the examination. Appendices are given at the back of this question paper.

*[Sila pastikan kertas soalan ini mengandungi **LAPAN (8)** muka surat yang bercetak termasuk muka hadapan sebelum anda memulakan peperiksaan ini. Lampiran-lampiran diberikan dibahagian belakang kertas soalan ini.]*

This question paper has **FOUR (4)** questions. Answer **ALL** questions. Each question contributes 20 marks.

*[Kertas soalan ini mengandungi **EMPAT (4)** soalan. Jawab **SEMUA** soalan. Markah bagi tiap-tiap soalan adalah 20 markah.]*

Question 1*[Soalan 1]*

- (a) Name and describe
- TWO**
- techniques of controlling the speed of induction motors.

[Namakan dan huraikan DUA teknik-teknik mengawal kelajuan motor aruhan.]

(5 Marks/ Markah)

- (b) A 415 V, four-pole, 50 Hz, Y-connected three phase induction motor is rated at 30 hp and rotates at 5 % slip. Its equivalent circuit components are shown in
- Table 1**
- . Calculate:

*[Motor aruhan tiga fasa 415 V, empat-kutub, 50 Hz, sambungan-Y dikadarkan pada 30 hp dan berputar pada 5 % gelinciran. Komponen litar setaranya ditunjukkan dalam Jadual 1. Kirakan:]***Table 1**
[Jadual 1]

Component Parameter <i>[Parameter Komponen]</i>	Value <i>[Nilai]</i>
R_1	0.100 Ω
R_2	0.070 Ω
X_M	10.0 Ω
X_1	0.210 Ω
X_2	0.210 Ω
P_{mech}	500 W
P_{misc}	0
P_{core}	400 W

- (i) the stator current.
-
- [arus pemegun.]*

(5 Marks/ Markah)

- (ii) the load torque.
-
- [daya kilas beban.]*

(3 Marks/ Markah)

- (iii) the overall motor efficiency.
-
- [kecekapan motor keseluruhan.]*

(7 Marks/ Markah)

....3/-

Question 2*[Soalan 2]*

- (a) Explain the conditions that are necessary for paralleling two synchronous generators.

[Terangkan syarat-syarat yang perlu untuk memadankan dua penjana bergerak secara selari.]

(6 Marks/ Markah)

- (b)
- Figure 2**
- shows two generators supplying a load. Generator 1 has a no-load frequency of 51.5 Hz and a slope (
- s_{p1}
-) of 1.5 MW/Hz while Generator 2 has a no-load frequency of 50 Hz and a slope (
- s_{p2}
-) of 3 MW/Hz. The two generators are supplying a total load of 3 MW at a power factor of 0.88 lagging.

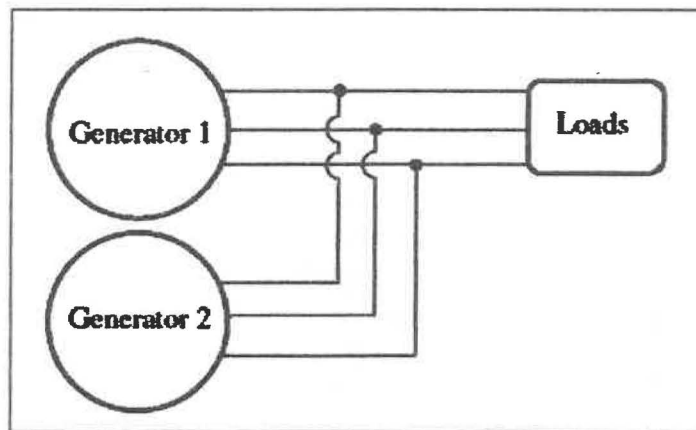
[Rajah 2 menunjukkan dua penjana yang membekalkan satu beban. Penjana 1 mempunyai frekuensi tanpa-beban 51.5 Hz dan kecerunan (s_{p1}) pada 1.5 MW/Hz manakala Penjana 2 mempunyai frekuensi tanpa-beban 50 Hz dan kecerunan (s_{p2}) pada 3 MW/Hz. Kedua-dua penjana tersebut membekalkan beban berjumlah 3 MW pada factor kuasa 0.88 mengekor.]**Figure 2***[Rajah 2]*

- (i) Calculate the operating frequency of this system and power supplied by each of the two generators.

[Kirakan frekuensi operasi sistem ini dan kuasa yang dibekalkan oleh setiap penjana.]

(8 Marks/ Markah)

- (ii) Assume an additional 2 MW load is attached to this power system and at the same time the governor set point of Generator 2 is now increased by 2 Hz. Evaluate the new system frequency and the new power that will be supplied by Generator 1 and Generator 2.

[Andaikan tambahan beban 2 MW kini dikenakan kepada sistem kuasa ini dan pada masa yang sama titik tetapan pengawal kelajuan Penjana 2 ditingkatkan sebanyak 2 Hz. Nilaikan frekuensi baru sistem dan kuasa baru yang dibekalkan Penjana 1 dan Penjana 2.]

(6 Marks/ Markah)

....4/-

Question 3*[Soalan 3]*

- (a) A synchronous motor produces torque only when it operates at synchronous speed. Since the field rotates at this speed, the motor must be accelerated to achieve synchronism. Explain the methods used to start a synchronous motor.

[Motor segerak menghasilkan daya kilas hanya apabila ia beroperasi pada kelajuan segerak. Oleh kerana medan berputar pada kelajuan ini, motor mesti memecut untuk mencapai keadaan segerak. Terangkan kaedah-kaedah bagi memulakan sebuah motor segerak.]

(6 Marks/ Markah)

- (b) Develop the schematic diagram of Direct Online (DOL) starter for three phase motor and explain its principal operation.

[Binakan gambarajah litar penghidup Talian Terus (DOL) untuk motor tiga fasa dan terangkan prinsip operasinya.]

(8 Marks/ Markah)

- (c) Differentiate the Direct Online (DOL) starter, star-delta starter and autotransformer starter.

[Bezakan penghidup Talian Terus (DOL), penghidup bintang-delta dan penghidup pengubahauto.]

(6 Marks/ Markah)

....5/-

Question 4*[Soalan 4]*

- (a) Briefly explain the shutdown maintenance and the breakdown maintenance that is always found in the industry.

[Terangkan secara ringkas penyelenggaraan penutupan dan penyelenggaraan kerosakan yang selalu terdapat di industri.]

(6 Marks/ Markah)

- (b) State **EIGHT (8)** failures and causes that can happen to the AC motor in the industry.

[Nyatakan LAPAN (8) kegagalan dan penyebab yang boleh berlaku kepada motor AU di dalam industri.]

(8 Marks/ Markah)

- (c) Describe the preventive maintenance that can be done to the AC motor.

[Nyatakan penyelenggaraan cegahan yang boleh dilakukan kepada motor AU.]

(6 Marks/ Markah)

...6/-

APPENDIX A
[LAMPIRAN A]

Basic Mathematical Formulae for Induction Motor	
Speed of the magnetic field's rotation	$n_{sync} = \frac{120f_e}{p}$
Slip speed	$n_{slip} = n_{sync} - n_m$
Slip	$s = \frac{n_{slip}}{n_{sync}} \times (100\%)$ $s = \frac{n_{slip} - n_m}{n_{sync}} \times (100\%)$ $s = \frac{\omega_{slip} - \omega_m}{\omega_{sync}} \times (100\%)$
Mechanical speed of the rotor shaft	$n_m = (1 - s)n_{sync}$ $\omega_m = (1 - s)\omega_{sync}$
Rotor frequency	$f_r = sf_e$ $f_r = \frac{n_{sync} - n_m}{n_{sync}} f_e$ $f_r = (n_{sync} - n_m) \frac{p}{120f} f_e$ $f_r = \frac{p}{120} (n_{sync} - n_m)$
Efficiency of the induction motor	$\eta = \frac{P_{out}}{P_{in}} \times 100\%$
Torque	$\tau_{ind} = \frac{P_{AG}}{\omega_{sync}}$ $\tau_{load} = \frac{P_{out}}{\omega_m}$
Mathematical Formulae for Three-Phase Induction Motor	
Rotor reactance	$X_R = \omega_r L_R$ $X_R = 2\pi f_r L_R$ $X_R = 2\pi s f_e L_R$ $X_R = sX_{RO}$
Rotor current	$I_R = \frac{E_R}{R_R + jX_R}$ $I_R = \frac{E_R}{R_R + jsX_{RO}} \quad ; X_R = sX_{RO}$ $I_R = \frac{E_{RO}}{R_R/s + jX_{RO}} \quad ; E_R = sE_{RO}$
Equivalent rotor impedance	$Z_{R,eq} = \frac{R_R}{s} + jX_{RO}$
Input current to a phase of the motor	$I_1 = \frac{V_\phi}{Z_{eq}} = \frac{V_\phi}{Z_{tot}}$

...7/-

Total equivalent impedance	$Z_{eq} = R_1 + jX_1 + \frac{1}{G_C - jB_M + \frac{1}{\frac{V_2}{s} + jX_2}}$
Total impedance	$Z_{tot} = Z_{stator} + Z_f$
Conductance	$G_C = \frac{1}{R_C}$
Susceptance	$B_M = \frac{1}{X_M}$
Stator impedance	$Z_{stator} = R_1 + jX_1$
Combined magnetization plus rotor impedance	$Z_f = \frac{1}{\frac{1}{jX_m} + \frac{1}{Z_2}}$
Referred rotor impedance	$Z_2 = \frac{R_2}{s} + jX_2$
Rotor power factor	$PF_R = \cos \theta_R = \cos \left(\tan^{-1} \frac{sX_{RO}}{R_R} \right)$
Input and output power of the motor	$P_{in} = \sqrt{3}V_T I_L \cos \theta$ $P_{out} = P_{conv} - P_{F\&W} - P_{misc}$
Stator Copper Loss	$P_{SCL} = 3I_1^2 R_1$
Core Losses	$P_{core} = 3E_1^2 G_C$
Rotor Copper Loss	$P_{RCL} = 3I_2^2 R_2 = sP_{AG}$
Air Gap Power	$P_{AG} = P_{in} - P_{SCL} - P_{core} = 3I_2^2 \frac{R_2}{s}$ $P_{AG} = \frac{3V_{TH}^2 \frac{R_2}{s}}{\left(R_{TH} + \frac{R_2}{s} \right)^2 + (X_{TH} + X_2)^2}$
Power converted from electrical to mechanical form	$P_{conv} = P_{AG} - P_{RCL}$ $P_{conv} = 3I_2^2 R_2 \left(\frac{1-s}{s} \right)$ $P_{conv} = (1-s)P_{AG}$
Induced Torque	$\tau_{ind} = \frac{P_{conv}}{\omega_m}$ $\tau_{ind} = \frac{3V_{TH}^2 \left(\frac{R_2}{s} \right)}{\omega_{sync} \left[\left(R_{TH} + \frac{R_2}{s} \right)^2 + (X_{TH} + X_2)^2 \right]}$
Maximum pullout torque	$\tau_{max} = \frac{3V_{TH}^2}{2\omega_{sync} \left[R_{TH} + \sqrt{R_{TH}^2 + (X_{TH} + X_2)^2} \right]}$

....8/-

Starting torque	$\tau_{start} = \frac{3V_{TH}^2 R_2}{\omega_{sync} [(R_{TH} + R_2)^2 + (X_{TH} + X_2)^2]}$
Slip of pullout torque	$S_{max} = \frac{R_2}{\sqrt{R_{TH}^2 + (X_{TH} + X_2)^2}}$
Thevenin voltage	$V_{TH} = \frac{jX_M}{R_1 + jX_1 + jX_M} V_\phi$ $V_{TH} = \frac{X_M}{\sqrt{R_1^2 + (X_1 + X_M)^2}} V_\phi$ $V_{TH} \approx V_\phi \frac{X_M}{X_1 + X_M}$
Thevenin impedance	$Z_{TH} = \frac{Z_1 Z_M}{Z_1 + Z_M}$ $Z_{TH} = R_{TH} + jX_{TH}$ $Z_{TH} = \frac{jX_M(R_1 + jX_1)}{R_1 + j(X_1 + X_M)}$
Thevenin resistance	$R_{TH} \approx R_1 \left(\frac{X_M}{X_1 + X_M} \right)^2, \quad X_{TH} \approx X_1$
Current I_2	$I_2 = \frac{V_{TH}}{Z_{TH} + Z_2} = \frac{V_{TH}}{R_{TH} + \frac{R_2}{S} + jX_{TH} + jX_2}$ <p>Magnitude current:</p> $I_2 = \frac{V_{TH}}{\sqrt{\left(R_{TH} + \frac{R_2}{S}\right)^2 + (X_{TH} + X_2)^2}}$
Mathematical Formulae for Synchronous Generator	
Electrical frequency	$f_e = \frac{n_m P}{120}$
Speed droop	$SD = \frac{n_{nl} - n_{fl}}{n_{fl}} \times 100\%$
Power output of a generator	$P_{out, gen} = S_p (f_{nl} - f_{sys})$
Total power	$P_{tot} = P_{load} = P_{G1} + P_{G2}$
Total reactive power	$Q_{tot} = Q_{load} = Q_{G1} + Q_{G2}$

-0000000-