

Real-Time Monitoring for Mechanical Boiler Chamber Using IoT Application

Mohammad A'mirul Ahmad Fauzi¹, Muhamad Syazmie Sepeeh¹ and Shamsul Aizam Zulkifli^{1*}

¹Department of Electrical Power Engineering, Faculty of Electrical and Electronics Engineering, Universiti Tun Hussein Onn Malaysia, 86400 Batu Pahat, Johor

ABSTRACT

Nowadays, more and more IoT applications have been integrated into manufacturing activities. Therefore, this project develops a monitoring system for mechanical boiler chamber using the internet of things (IoT) application in real-time monitoring. This real-time monitoring is connected between temperature, vibration, and motion sensors with Node MCU ESP8266 to establish the IoT network. An advantage of Node MCU ESP8266 where it can communicate to the smartphone at the same Wi-Fi. The sensors response will be displayed on the Blynk IoT platform. During actual monitoring, the Blynk IoT is used to show the real-time data flow for the temperature, vibration, and motion actions before the power is disconnected if the boiler operates more than the allowable limit. All results obtained in real-time can be accessed using a smartphone. At the end of the sensors, the smartphone can see the output for immediate action when necessary.

Keywords: Boiler monitoring, Blynk, ESP8266, IoT, Wi-Fi

1. INTRODUCTION

Internet of Things (IoT) can collect real-time data and transfer it to the internet cloud to be managed by the user at any place. This application has been applied to the mechanical boiler chamber that required the temperature [1], vibration and motion for complex operations to avoid a broken section. However, in [1], the paper used Arduino as for microcontroller compared to this project which uses an ESP module, which is a smaller size that suitable for sensors that needed to reduce the cost of the system and at the same time, the ESP has its built Wi-Fi module. Other than that, to increase the efficiency of the boiler applied to the heating system, it needs constant monitoring [2], which can be implemented in IoT. Nowadays, sensors that can be used at the boiler to sense the electrical source's heat, vibration, and movement can be interpreted in the electrical system. As for the temperature excursions, the energy loss in the temperature sensor can enhance the boiler's efficiency [3]. For example, in biomedical engineering, the blood pressure, pulse rate, and respiration rate could influence temperature change [4], monitored in real-time. With the advancement of phone apps, the phone or smartphone connection with IoT reduces the gap between physical and digital, especially in industrial [5]. The high level of IoT is where the SCADA system collects more measurements from the peripheral and converts the information to the computer program format for the next process step [6]. As for the water detector model, the faulty motorised fault affects the thermostat and water level reading [7]. Paper [8] is used the Blynk IoT system with the humidity sensor to be applied for the environmental drone system.

As for the boiler concept, choosing and protecting the boiler from overheat is by applying sensors that can notify the conditions as quickly as possible. It avoids broken due to overheating [7] and to animal intruder such as rat [9] that affects the boiler's performance. Therefore, an IoT interface

*aizam@uthm.edu.my

is needed if many data sources are required and simultaneously store real-time data before it can be analysed to forecast the boiler's health further. An online system such as ThinkSpeak is collect and analyse the data from sensors [10]. On others, Blynk is also one of the friendly software and more accessible to be developed. Blynk software and set up buttons, sliders, graphs and other widgets on the computer [11].

Figure 1 shows the project configuration where it used Node MCU ESP8266 as the microcontroller. This microcontroller is embedded with the flow process program that determined the input and output to be processed. Among sensors involve in this project are heat generation such as temperature, vibration, and motion sensors. The Node MCU receives data from the sensors then sends this real-time data using a wireless network to communicate with the Blynk IoT platform installed in the smartphone at the same Wi-Fi configuration. The display set is shown on the smartphone for the user to see the real-time data. It allowed the boiler to be protected at all the time. The paper has been organised where developing the software using python for IoT integration, and the hardware configuration has been further explained in section 2. In Section 3, the results on the outcome from the sensors have been integrated with smartphone monitoring configuration. In the end, Section 4 is concluded the finding of this project which achieved the IoT system.

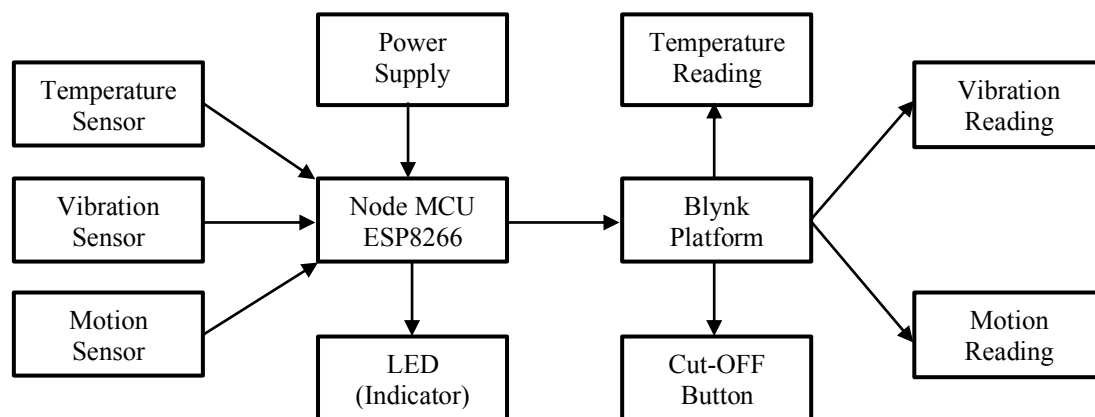

Figure 1. Block diagram of real-time monitoring boiler chamber using IoT application.

2. DESIGN PROCESS OF SOFTWARE AND HARDWARE

The central part of this design process is the Node MCU. It is known as a brain for the IoT system. The Node MCU can be connected to the wireless configuration of the available network to transmit the data with a bidirectional mechanism for the following process. All the sensors applied to this project are suitable to be located at the body of the boiler chamber. It stored the specific program to be integrated. The flow process for the software and hardware is being shared in this paper to help the reader build a monitoring system with more response time and ability, as shown in Figure 2.

Figure 3 explain the connection between sensors that are connected to the microcontroller. The only sensor that uses analogue input is the temperature sensor. The signal from other sensors except the temperature sensor using a GPIO pin. The ESP8266 controller board has been declared on the library of the Arduino software. Meanwhile, the vibration and motion sensor are used digital pin. This part is essential due to all components are needed to communicate and interpreted the data. Therefore, the signal sent to the cloud through the ESP8266 can

interconnect with the internet. C++ is the programming language used in Arduino software and added with some codes connecting with Blynk.

After the communication between node MCU and Blynk is established, with all the sensors, the temperature, motion, and vibration sensor, an actual data signal can be observed from the smartphone. For the power cut test, the relay opening has been replaced with the LED where will be operated when all the sensors reach their maximum threshold. This indication has also been displayed on the Blynk. One analogue pin in Node MCU is mentioned, so it is only for the temperature sensor. Analog pin must be declared on the Blynk platform in the virtual category with the available GPIO same goes with motion and vibration sensors. The signal from the sensors is converted from the digital output by using node MCU. Any verified data straight away display in the Blynk that has been developed in a smartphone has been confirmed. If the sensor detects an abnormality, for example, the vibration sensor detects high vibration at the boiler, the Blynk notification appears through the smartphone.

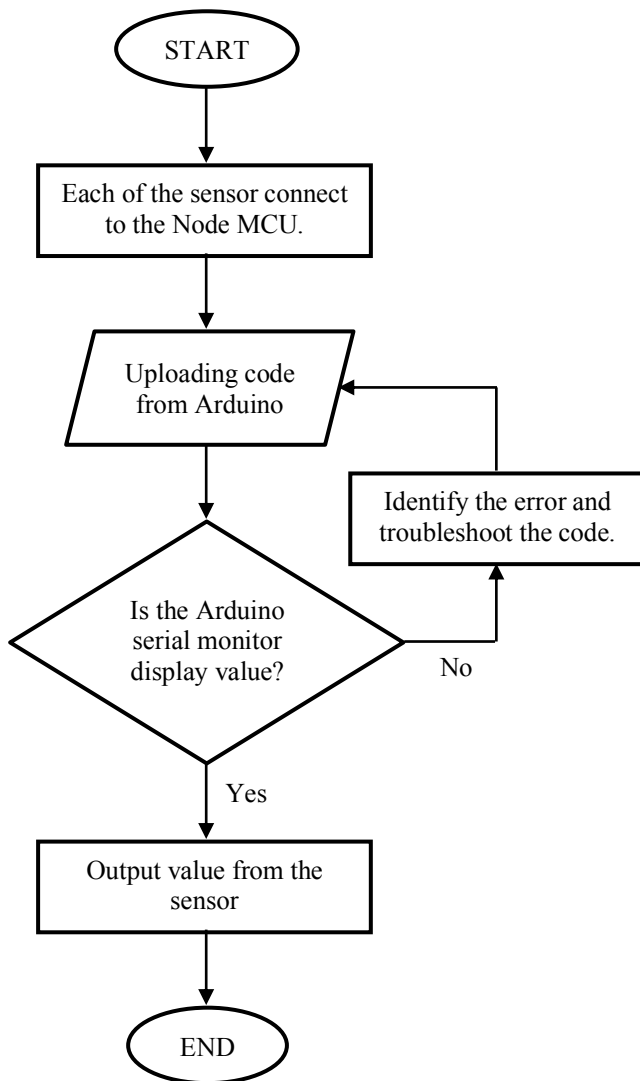

Figure 2. Flowchart of the process of the project.

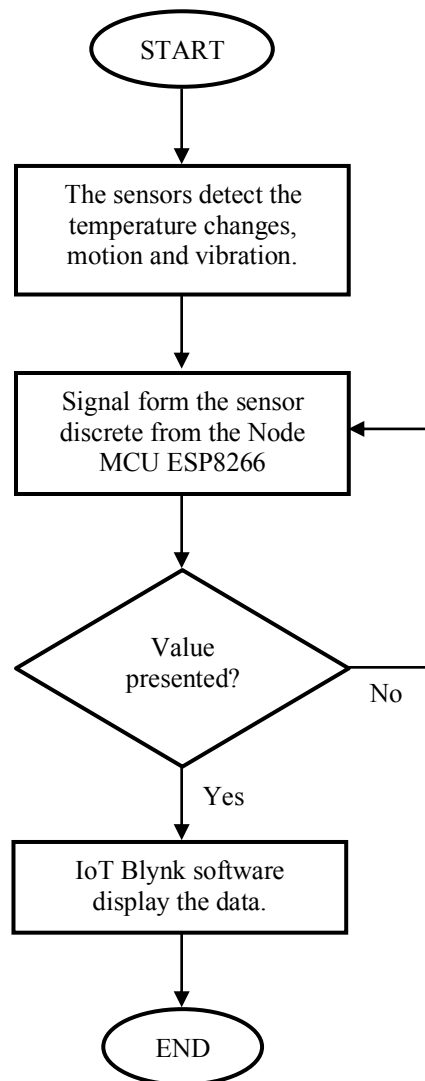

Figure 3. Flowchart of sensor integration for the system.

Figure 4 illustrates the flowchart of the monitoring system by using Blynk based on a microcontroller, and it can be created using Superchart that is available in Blynk Widget Box. The Wi-Fi ID, a password is needed to establish the network communication before uploading with

the code. If the result cannot display as the command, troubleshoot the error of the coding is required. While the value expressed as a command displayed on the smartphone also needs to be added for simple understanding. Figure 5 shows the IoT hardware setup for the project with all the components. The actual sensors connect for the hardware such as temperature, vibration, motion sensors, and LED to replace the relay with Node MCU ESP8266.

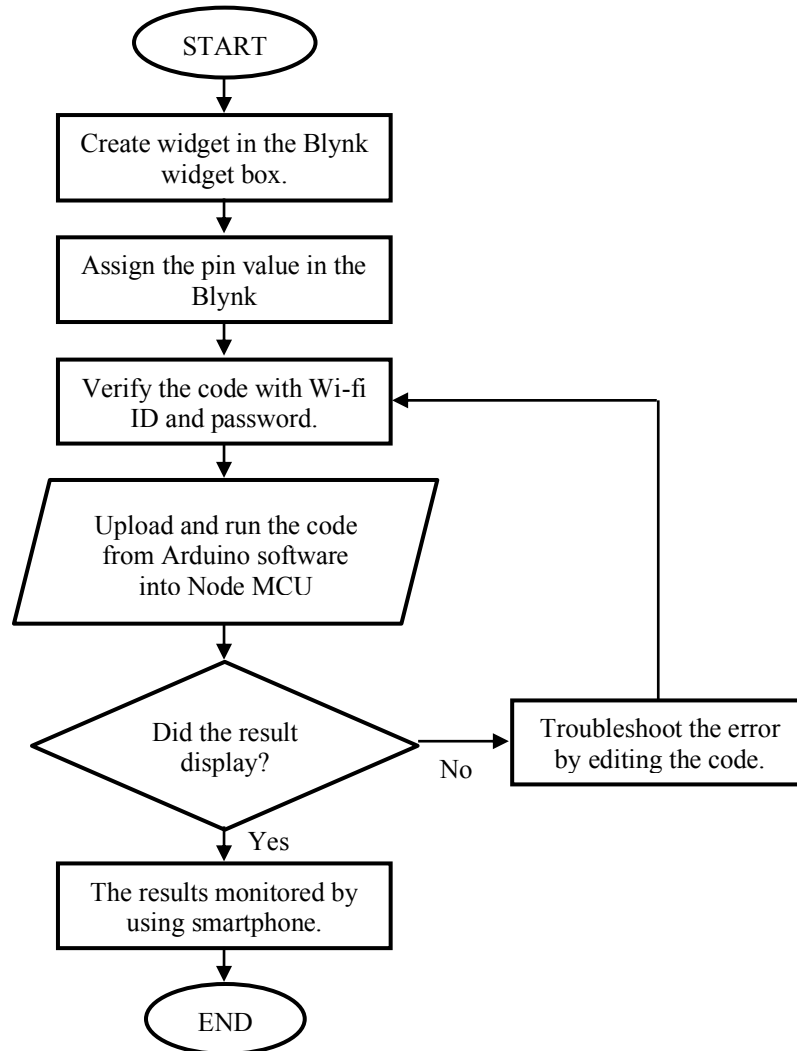

Figure 4. The flow of the Blynk process.

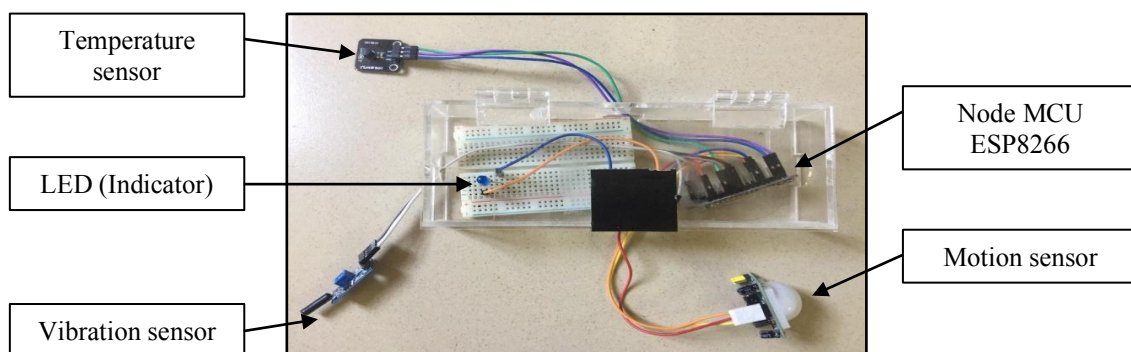

Figure 5. IoT hardware setup.

3. RESULTS AND DISCUSSIONS

The results from the project are being categorised between the responses of the sensors. It displays between the node MCU and the Blynk. Communication is the first result that needs to be established among the Node MCU and sensors. The MCU has been written based on Arduino language due to its simplicity, and it is straightforward to be developed. Figure 6 shows the programming applied for temperature, motion and vibration sensor displayed in Arduino recording. The data value can be displayed on the Node MCU GUI if the communication between the sensors and the software has been integrated, as shown here.

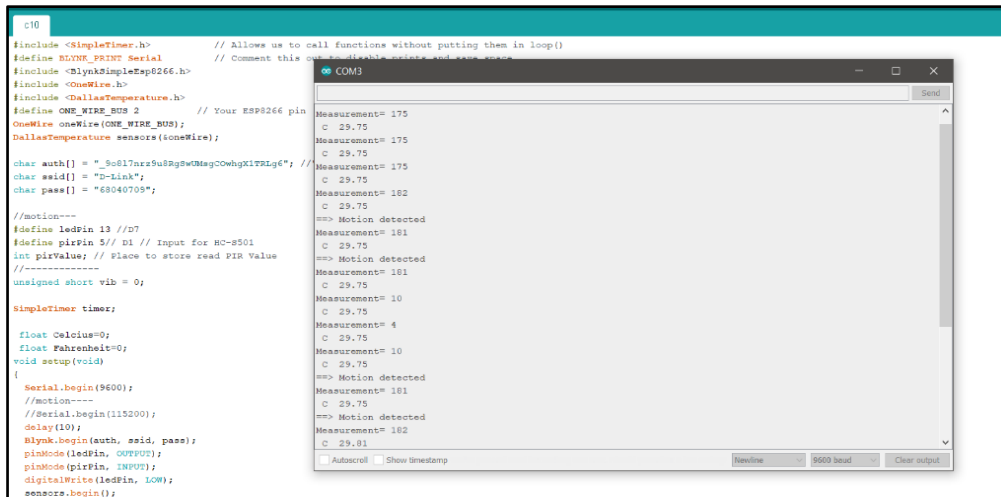
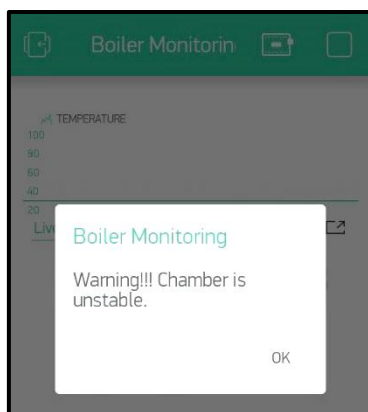
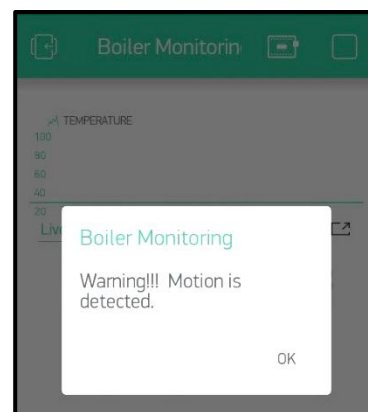

Figure 6. Arduino programming language for temperature, motion, and vibration sensors.

Figure 7 shows the output display from the sensors using Blynk in the actual application. The IoT system has been placed on the hotbox material for behaving as a boiler system. The Blynk software has been installed and running on the smartphone. This output is the real-time output where any changes at the sensors will show on the Blynk Apps. The vibration setting is between 175 to 182 units, as shown in Figure 7 (a). If the signal calculates the value between this range and indication to the phone will be notified as "Warning!!! Chamber is unstable". The "Motion is detected" mean when using the motion sensor where any displacement to give a notification written as "Warning!!! Motion is detected" be displayed by the sensor on the smartphone as shown in Figure 7(b). As for the temperature sensor, the range between 40°C to 60°C is a cut-off limit, and the notification is written as "Warning!!! Temperature too high", as shown in Figure 7(c) and (d). Table 1 is the temperature test to make sure the system is in ready condition.



(a)



(b)

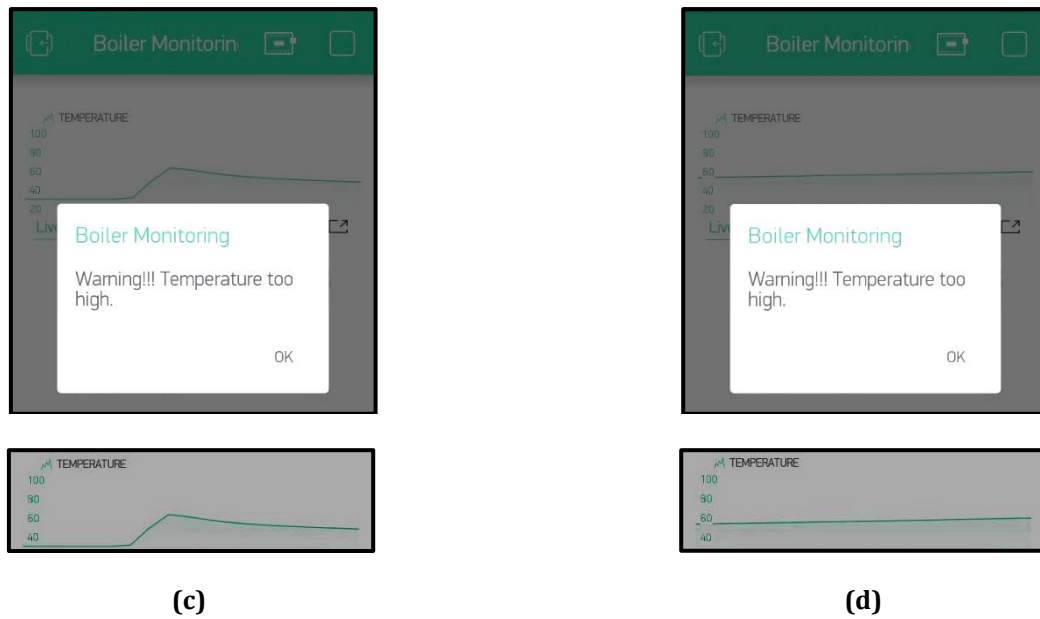

Figure 7. Sensors output signal notification in the smartphone: (a) vibration; (b) motion; (c) temperature at 40°C and (d) temperature at 60°C.

Table 1 The temperature reading for before and after testing.

Test condition	Temperature (°C)	Cut-off limit (°C)
Temperature room	30	-
The heat from lighter	40-50	40
The heat from boiling water	60-100	60

Figure 8 shows the overall display set in the IoT Blynk platform that appeared on the smartphone. All the outputs can be easily monitored with this simple interface. Any warning that occurs could be notified immediately, especially for vibration and motion sensors. At the same time, the temperature could be monitored in real and live data recorded on the IoT cloud before any warning is given if the temperature is more than the set limit.

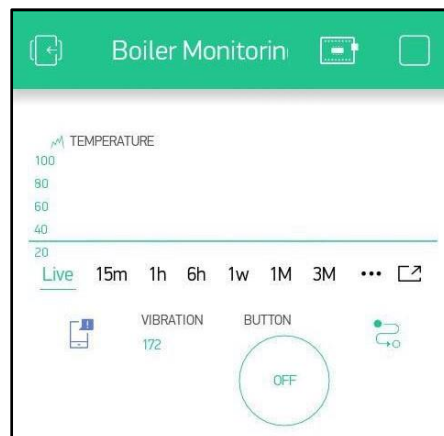

Figure 8. Boiler chamber monitoring display in a smartphone at room condition.

4. CONCLUSION

In conclusion, designing the dashboard of the Blynk in the smartphone gives a new way to integrate the hardware and the IoT network. Therefore, this project has been able to apply IoT system configuration that can be used for remote monitoring systems, especially for boiler systems where required 24 hours monitoring. All the sensors are being integrated into each other's where the temperature sensor is essential and needs to be monitored in continuous mode with display the actual data display and give initial warning of the boiler. Besides that, the vibration on the chamber must be frequently observed to estimate any surface cracking that appeared. As for the motion sensor is to see any displacement of the boiler that required high maintenance cost in the future. The development of heat and vibration monitoring systems for IoT applications to obtain real-time results has been successfully conducted and created a real-time monitoring system.

ACKNOWLEDGEMENTS

The authors gratefully acknowledge that he is supported by Universiti Tun Hussein Onn Malaysia (UTHM) through MDR (Vot H488), and Advanced Control on Power Converter Group of Universiti Tun Hussein Onn Malaysia undertake this research activity.

REFERENCES

- [1] Gnanavel, C., Satish Khanna, P., Rajavelan, M., Vanchinathan, K., and Gokul, C., "Real Time Monitoring and Controlling of Boiler Drum Parameters using Internet of Things (IoT)", *Test Engineering and Management*. vol **82**, issue January-February (2020) pp.2195-2198.
- [2] Varpe, J. R., and Kathwate, S. D., "Boiler Efficiency Monitoring and Boiler Losses Analysis: A Review", *International Journal on Theoretical and Applied Research in Mechanical Engineering*. vol **5**, issue 1 (2016) pp.62-65.
- [3] Djayanti, S., "Energy Efficiency Improvement Strategies for Boilers: A Case Study in Pharmacy Industry", *E3S Web of Conferences*. vol **125**, issue 12002 (2019) pp.1-6.
- [4] Yi, C. S., Abdul Shukor, S. A., Rahim, N. A., Kohlhof, K., and Jamal, Z. A. Z., "Internet-of-things (IoT) for human thermal comfort: A simulative investigation", *Journal of Telecommunication, Electronic and Computer Engineering*. vol **10**, issue 1-14 (2018) pp.119-123.
- [5] Sisinni, E., Saifullah, A., Han, S., Jennehag, U., and Gidlund, M., "Industrial Internet of things: Challenges, opportunities, and directions", *IEEE Transactions on Industrial Informatics*. vol **14**, issue 11 (2018) pp.4724-4734.
- [6] *SCADA System Fundamentals*, Credit: 1 PDH., Continuing Education and Development, Inc., T. Adams, NY, (2014) pp. 1-24.
- [7] Dinakaran, C., "Temperature and Water Level Control in Boiler by using Fuzzy Logic Controller", *International Journal of Electrical Power System Technology*. vol **1**, issue 1 (2015) pp.27-37.
- [8] Zulkifli, S. A., Mohammad Shukor, M. H. F., Razman, F. N., Abd Wahab, M. H., and Syed Idrus, S. Z., "Air Drone Pollution Monitoring System with Self Power Generation", *Journal of Physics Conference Series*, IOP PUBLISHING LTD. vol **1529**, issue April (2020) pp.022103.
- [9] D. K. Tiwari and M. A. Ansari, "Electronic Pest Repellent: A Review", in *2016 International Conference Innovations in Information Embedded Communications Systems*, Coimbatore, Tamil Nadu, India, (2016) pp.435-439.

- [10] Nettikadan, D., and Raj, S., "Smart Community Monitoring System using Thingspeak IoT Platform," *International Journal Applied Engineering Research*. vol **13**, issue 17 (2018) pp.13402-13408.
- [11] Controlling Arduino Board with Smartphone and Blynk via Internet, Tech. Doc., Researchgate, M. Todica, Romania, (2016) pp. 1-20.