



**DESIGN OF MICRO-WIND TURBINE FOR STAND  
ALONE APPLICATION**

by

**AMIRUL SYAFIQ BIN ZAMRY  
(1632221974)**

A dissertation submitted in partial fulfilment of the requirements for the  
degree of Master of Science Electrical Power Engineering

**School of Electrical System  
UNIVERSITI MALAYSIA PERLIS**

2017

UNIVERSITI MALAYSIA PERLIS (UniMAP)  
SCHOOL OF ELECTRICAL SYSTEM ENGINEERING  
DECLARATION OF REPORT

Author's full name : Amirul Syafiq Bin Zamry  
Date of birth : 30<sup>th</sup> July 1991  
Title : Design of Micro-wind Turbine for Stand Alone Application  
Academic Session : 2016/2017

I hereby declare that the report becomes the property of Universiti Malaysia Perlis (UniMAP) and to be placed at the library of UniMAP. This report is classified as:

**CONFIDENTIAL** (Contains confidential information under the Official Secret Act 1972)\*

**RESTRICTED** (Contains restricted information as specified by the organization where research was done)\*

**OPEN ACCESS** I agree that my report is to be made immediately available as hard copy or on-line open access (full text)

I, the author, give permission to the UniMAP to reproduce this report in whole or in part for the purpose of research or academic exchange only (except during a period of \_\_\_\_\_ years, if so requested above).

Certified by:

\_\_\_\_\_  
**SIGNATURE**

\_\_\_\_\_  
**SIGNATURE OF SUPERVISOR**

\_\_\_\_\_  
**(910730-08-6233)**

\_\_\_\_\_  
**DR. NORKHARZIANA BT MOHD  
NAYAN**

Date : \_\_\_\_\_

Date : \_\_\_\_\_

**\*NOTES:** If the report is CONFIDENTIAL or RESTRICTED, please attach with the letter from the organization with period and reasons for confidentially or restriction.

## ACKNOWLEDGEMENT

First of all thanks to Allah SWT for the blessing opportunity for me to finish this Thesis. Special thanks to my Master Project's supervisor Dr. Norkharzaina Binti Mohd Nayan for her helps, advices and support during my thesis. Without her guidance and persistent help, my thesis would not have been possible and of course I will not be able to gain knowledge and experience from the thesis too. All his comment and critics is guidance for producing a good work and report.

I would like to extend my gratitude to School of Electrical System Engineering and the Master Project coordinator for Electrical Power Engineering for providing me the chance to undertake this Master Project.

Thanks also to my family and friends that support me direct or indirect which make me motivated to complete this project as soon as possible.

Thank you.

## TABLE OF CONTENTS

	<b>PAGE</b>
<b>THESIS DECLARATION</b>	<b>i</b>
<b>ACKNOWLEDGMENT</b>	<b>ii</b>
<b>TABLE OF CONTENTS</b>	<b>v</b>
<b>LIST OF TABLES</b>	<b>viii</b>
<b>LIST OF FIGURES</b>	<b>ix</b>
<b>ABSTRAK</b>	<b>x</b>
<b>ABSTRACT</b>	<b>xi</b>
<b>CHAPTER 1 INTRODUCTION</b>	
1.1 Introduction	1
1.2 Problem Statement	2
1.3 Research Objective	3
1.4 Project Scope	4
1.5 Report outline	5
<b>CHAPTER 2 LITERATURE REVIEW</b>	
2.1 Introduction	6
2.2 DC Brushless motor	7
2.2.1 Basic Components of DC Brushless Motor	9
2.2.2 DC Brushless motor used as a generator	11
2.2.3 Brushless DC Motor	18
2.3 Schottky Diode	19
2.4.1 Characteristics of Schottky diode	20

2.4	Rectifier	20
2.4.1	Single phase rectifier	20
2.4.2	Single phase half wave rectifier	20
2.4.3	Single phase full wave rectifier	22
2.5	Voltage regulator	26
2.5.1	Integrated Circuit Voltage Regulator.	27
2.5.2	Fixed Positive and Negative Linear Voltage Regulator.	28
2.6	Energy storage	30
2.6.1	Lead Acid Battery	31
2.6.2	Nickel-Cadmium (Ni-Cd) and Nickel-Metal Hydride (Ni-MH) Batteries	32
2.6.3	Lithium-Ion (Li-Ion) Batteries	34
2.6.4	Ultra Capacitor (UC)	34
2.7	Recent development of micro-wind turbine	36
2.8	Challenge of wind turbine in Malaysia	38

### **CHAPTER 3 METHODOLOGY**

3.1	Introduction	41
3.2	Circuit operation	43
3.2.1	Generator	44
3.2.2	Single phase full-wave bridge rectifier.	47
3.2.3	Voltage regulator	51
3.3	The generator circuit configuration	53
3.3.1	Series configuration	54
3.3.2	Parallel configuration	55
3.3.3	Series parallel configuration	56

### **CHAPTER 4 RESULT AND DISCUSSION**

4.1	Introduction	57
4.2	Experiment setup	57
4.2.1	Voltage measurement	58

4.2.2	Current measurement	59
4.2.3	Wind speed and generator speed measurement	60
4.3	Series configuration	61
4.4	Series parallel configuration	62
4.5	Parallel configuration	63
4.6	Experimental with energy storage	64
4.7	Discussion	66
<b>CHAPTER 5 CONCLUSION</b>		
5.1	Summary	69
5.2	Recommendation for Future Work	69
<b>REFERENCES</b>		<b>71</b>

©This item is protected by original copyright

## LIST OF FIGURES

NO		PAGE
2.1	A brushless DC motor and its associated control unit	8
2.2	A voltages applied to the stator coils.	9
2.3	A rotor and a permanent magnet placed on the rotor.	12
2.4	A stator mounted on the desktop fan frame.	12
2.5	An Integrated Circuit (IC) is placed on the circuit.	13
2.6	A schematic diagram of 2-wire desktop fan with hall sensor.	14
2.7	A desktop fan with two wires.	14
2.8	A schematic diagram of three wire desktop fan with hall sensor and Tacho.	15
2.9	A desktop fan with three wires.	16
2.10	A schematic diagram of four wire desktop fan.	17
2.11	A desktop fan with four wires.	17
2.12	A single-phase half-wave rectifier with resistive load.	21
2.13	The voltage and current waveforms of the half-wave rectifier with resistive load.	22
2.14	A full wave rectifier with center-tapped transformer.	23

2.15	The voltage and current waveform of full wave rectifier with center tapped transformer.	24
2.16	A bridge rectifier.	25
2.17	The voltage and current waveform of the bridge rectifier.	26
2.18	A basic connection of a three-terminal IC voltage regulator.	27
2.19	The 78XX series fixed positive voltage regulator.	28
2.20	The 79XX series fixed negative voltage regulator.	29
2.21	A micro-wind turbines arranged in series combination.	37
2.22	The wind speed taken at several places. The wind speed is taken from 1st January to 31st August 2014.	39
2.23	The two wind turbine installed on Perhentian Island.	40
3.1	A general methodology flowchart.	42
3.2	A schematic circuit of micro-wind turbine in series connection.	43
3.3	A block diagram for micro-wind turbine project.	44
3.4	A 24V DC desktop fan.	45
3.5	An unregulated AC waveform of desktop fan.	45
3.6	Construction of the generator.	46
3.7	Replacement of motor driver.	46
3.8	A waveform and peak voltage after removing the IC.	47



3.9	A schematic diagram of full-wave bridge rectifier.	47
3.10	Rectifier hardware circuit.	48
3.11	Measurement $V_f$ of 1N5818 Schottky diode.	48
3.12	An unregulated DC voltage waveform.	49
3.13	A frequency at 104.67Hz when desktop fan speed is 1513 rpm.	50
3.14	A frequency at 71.84Hz when desktop fan speed is 1218 rpm.	50
3.15	A linear dc waveform when a $100\mu\text{F}$ capacitor is applied into rectifier circuit.	51
3.16	A schematic diagram of voltage regulator.	51
3.17	Voltage regulator circuit hardware.	52
3.18	A DC waveform with output voltage at 5V.	53
3.19	A schematic diagram of series configuration of micro-wind turbine.	54
3.20	A schematic diagram of parallel configuration of micro-wind turbine.	55
3.21	A schematic diagram of series parallel configuration of micro-wind turbine.	56
4.1	Experiment setup in CERE laboratory.	58
4.2	Experimental setup for voltage measurement.	59
4.3	Experiments setup for current measurement.	59
4.4	Wind source experimental purpose.	60
4.5	Digital tachometer DT-2234C.	60

4.6	The voltage and current results for series configuration versus wind speed.	61
4.7	The voltage and current results for series parallel configuration versus wind speed.	62
4.8	The voltage and current results for parallel configuration versus wind speed.	63
4.9	An energy storage in charging mode.	65
4.10	The speed of generator versus wind speed.	66
4.11	The generated voltage versus wind speed.	67
4.12	The generated current versus wind speed.	68

©This item is protected by original copyright

## LIST OF TABLES

NO.		PAGE
2.1	The minimum and maximum of voltage for 78XX series voltage regulator.	30
2.2	The minimum and maximum of voltage for 79XX series voltage regulator.	31
3.1	The specification of generator	44
3.2	The effect frequency of desktop cooling fan with changing of wind speed.	49
4.1	The specification of energy storage used for experiment.	64

©This item is protected by original copyright

## LIST OF SYMBOLS

$B_S$	Stator magnetic field.
$C_1$	Input capacitor.
$C_2$	Output capacitor.
$I_{G1}$	First generator current.
$I_{G2}$	Second generator current.
$I_{G3}$	Third generator current.
$I_{G4}$	Fourth generator current.
$I_{GT}$	Total generator current.
$I_L$	Load current.
$kB_R$	Rotor magnetic field.
$L di/dt$	Inductor in Laplace transform.
$\tau_{ind}$	Torque .
$V_d$	Diode voltage. Same as forward voltage.
$V_{D1}$	First diode voltage.
$V_{D2}$	Second diode voltage.
$V_{D3}$	Third diode voltage.
$V_{D4}$	Fourth diode voltage
$V_{dc}$	Direct Current voltage.
$V_f$	Forward voltage for diode.
$V_{G1}$	First generator voltage.
$V_{G2}$	Second generator voltage.
$V_{G3}$	Third generator voltage.
$V_{G4}$	Fourth generator voltage.
$V_{GT}$	Total generator voltage.
$V_i$	Input voltage.
$V_L$	Load voltage.
$V_m$	Amplitude voltage for AC source.
$V_O$	Output voltage.
$V_{RRM}$	Peak repetitive reverse voltage.
$V_S$	Voltage source.

## LIST OF ABBREVIATIONS OR NOMENCLATURE

AC	Alternating Current.
DC	Direct Current.
IC	Integrated Circuit.
LED	Light Emitted Diode.
MOSFET	Metal Oxide Field Effect Transistor.
MV	Megawatt.
PC	Personal Computer
PWM	Pulse Width Modulator.
PIV	Peak Inverse Voltage.
R	Resistor.
RF	Radio Frequency.
RPM	Rotation Per Minute

©This item is protected by original copyright

## **Merekabentuk kincir angin mikro untuk aplikasi sendiri**

### **ABSTRAK**

Thesis ini adalah mengenai mereka dan membangunkan kincir angin mikro untuk aplikasi sendiri. Faktor-faktor yang terlibat dalam mereka ialah jenis penjana, jenis penerus, pengatur voltan dan simpanan tenaga. Beberapa faktor seperti termasuk litar seperti litar siri, litar selari dan litar siri selari adalah penting dipelajari dalam memastikan litar yang terbaik dalam menghasikan voltan dan arus keluar. Faktor lain yang mempengaruhi projek ini ialah kelajuan angin, kelajuan penjana, jenis penerus dan jenis pengatur voltan. Faktor ini akan mempengaruhi voltan dan arus keluar. Projek ini terdiri daripada empat penjara menggunakan motor penyejuk PC yang telah diubahsuai litar, jambatan penerus, pengatur voltan dan tenaga simpanan. Data diambil dari alat pengukur termasuk multimeter, oscilloscope, tachometer dan anemometer. Selepas itu, data daripada alat pengukur tersebut digunakan untuk mendapatkan keputusan yang dikehendaki. Selain itu, perbandingan untuk voltan dan arus pada setiap litar juga dibincangkan. Pada penghujung laporan ini, kesimpulan mengenai penggunaan kincir angin mikro juga dibincangkan.

## **Design of Micro-wind Turbine for Stand Alone Application**

### **ABSTRACT**

This thesis is about the design and development of micro-wind turbine for standalone application. The design will consider the types of generator, rectifier, voltage regulator and energy storage. Several factors including the types of circuit such as series configuration, parallel configuration and series parallel configuration are important to study to ensure the suitable circuit configuration in micro-wind turbine which will give the best voltage and current output. The other factors that involve in this project are wind speed, generator speed, types of rectifier and voltage regulator. These factors are used to determine the output voltage and output current. This project consists of four generators taken from the modified circuit DC brushless PC cooling fans, four bridge rectifiers, a voltage regulator and an energy storage. Data are taken from measurement including a multimeter, an oscilloscope, a tachometer and an anemometer. After that, the data from measurement is used to obtain the desired results. In addition, the comparison of voltage and current in series configuration, parallel configuration and series parallel configuration are also discussed. At the end of this report, the conclusion about the using micro-wind turbine are also discussed.

# CHAPTER 1

## INTRODUCTION

### 1.1 Introduction

Wind energy is one of the potential renewable energy sources used for electricity. It uses kinetic energy from wind energy and convert it into electrical energy. The wind turbine consists of blade, pitch control, yaw control and generator. Normally, wind turbine has three blades with more than thirteen meters in diameter and tower with height is more than sixteen meters. It can generate more than 1kW of power with a minimum wind speed of five meter per seconds[ (THORSTENSSON)]. Manipulation of wind energy will reduce the air pollution. It also reduces reliance on fossil fuels. In 1991, the first offshore wind farm in the world was located in Denmark. Since then, more wind farms are constructed around the world (Ho, 2016).

The first wind turbine installed in Malaysia is located at Swallow reef, located some 200km from Kota Kinabalu, Sabah. It installed in 1996 with one wind turbine. This wind turbine can generate 150kW (The Ministry of Energy, 2009). In 2007, the second and third wind turbine was installed in Kapas island and Hentian island with capacity of 100kW. These installation of wind turbine in these area have an average wind speed of 5m/s (The Ministry of Energy, 2009).



## 1.2 Problem statement

There are several issue in wind farm and wind turbine

- a) A lot of space are required for constructing large scale wind farm.
- b) A Higher cost for construction and maintenance of wind farm.
- c) Safety issue of malfunctioning of wind turbine.
- d) A minimum 5 m/s of wind speed is required to operate the windmill.

A lot of space are required for constructing wind farm in large scale or small scale. The windmill consists of several of wind turbine to generate electricity but a larger space is required to construct them. A spacious land is required when installing a wind turbine. Meanwhile, a higher cost is involved for construction and maintenance of wind farm. The wind farm need a larger investment money for installation area and constructing wind turbine. The maintenance is required to make wind farm operate at optimum. Thus, the additional cost is needed to maintain them. In addition, safety issue on the malfunction of wind turbine also is take into account due to its large blades size and the height of the turbine tower. Usually, a minimum 5 m/s of wind speed is required to operate the windmill. Usually, many of windmill located at offshore where the wind speed is more than 5 m/s. If the wind speed is less than 5 m/s, the blade of wind turbine cannot rotate. Thus, the electrical energy cannot be produced.

### 1.3 Research Objectives

In this project, the following objectives are set to be achieved:

- a) To construct a hardware for micro-wind turbine with combination several wind turbine generators wind turbine with lower cost, modular and can be placed on small area.
- b) To design circuit configuration of generator in series, parallel or series parallel to give best voltage and current output based on wind speed.
- c) To implement a micro-wind turbine which can be operating at lower wind speed.

The first objective is to construct a hardware for micro-wind turbine with combination several wind turbine generators with lower cost, modular and can be placed on small area. The design of micro-wind turbine is in micro scale, therefore it can be located at any place that conventional wind turbine cannot be placed such as building, a rooftop house or so on. It is also design at lower cost since the cost of ordinary wind turbine are expensive.

The next objective is to design circuit of generator in series, parallel or series parallel in order to obtain optimum voltage and current output based on wind speed. This concept of micro-wind turbine inspired from Photovoltaic Solar cell which can arrange in series, parallel or array. These configurations would give an optimum voltage and current output. The last objective is to implement a micro-wind turbine prototype which can be operating and generating electrical energy at low wind speed.

## 1.4 Thesis Scope

This thesis is to design and develop a prototype of micro-wind turbine for stand-alone applications with a rated power of 5W. A hardware model is constructed based on low wind speed energy harvesting requirement. From hardware, several components characteristic are investigated to make a best modeling hardware of micro-wind turbine including generator, rectifier and voltage regulator.

In this research project, rectifier is used to convert AC voltage to DC voltage. A rectifier consists of diode and capacitor to filter the AC voltage. By using a bridge rectifier, a DC voltage can be generated. While for voltage regulator, it is designed to give fixed output voltage. The emphasis on design characteristics required for the voltage regulator includes:

- i. Capacitor – capacitance value, voltage rating and type of material.
- ii. Integrated Circuit (IC) – output voltage, minimum and maximum input voltage.

Lastly the energy storage is used for store energy. The voltage for energy storage must equally same be as output voltage at voltage regulator. It is important to prevent injury or damage the equipment when energy storage is in charging state.

## 1.5 Thesis Outlines

This thesis consists of five main chapters where all the concepts, activities and outcome of the project that are relevant throughout the project progress are documented. Chapter 1 discusses briefly about the project's introduction, background, problem statements, objectives and scope that give an overall idea of the project.

Chapter 2 is mainly about literature review which concentrated on the DC brushless motor, rectifier and inverter and voltage regulator where all useful equations related to the circuit are illustrated clearly in this chapter.

Chapter 3 concentrates on the methodology of this project, which includes the method in design of the proposed micro-wind generator including rectifier and voltage regulator. Besides that, the method in hardware design and construction of the project and as well as hardware testing are also included.

Chapter 4 is mainly discussing the results obtained through hardware testing, and the comparison between these circuit configurations of results which include the result from wind speed, speed of generator, voltage and current.

Lastly, Chapter 5 is the conclusion of the research project and possible recommendation is suggested to further improve this project in the future.

## CHAPTER 2

### LITERATURE REVIEW

#### 2.1 Introduction

Installed wind capacity has increased globally by an average of 23% over the past 18 years according to the Global Wind Energy Council (Ho, 2016). Despite the fact that wind energy is one of the fastest growing renewable energy sources today, there is limited literature on micro-wind turbine technology. Micro-wind turbines are generally characterized as small-scale turbines designed for use by individuals rather than for large scale energy or grid production. Although the power output of micro-wind turbines is much less than small and large-scale wind turbines, micro-wind turbines are less costly, easier to install, and can empower small electrical devices such as LED signs and cell phones (Bahaj A.S, 2014).

Current implementation and development for wind energy applications are exclusively focused on large-scale wind turbines that produce electricity for grid-tied markets. Large-scale turbines produce energy on the scale of megawatts (MW) and require large logistical and development efforts that may last several years or even decades. Small-scale wind turbines are still a minority part of the wind turbine market. However, demand is increasing due to a rising interest for turbines in general (THORSTENSSON). Small-scale turbines are larger than micro-wind turbines, the latter

ideally used on buildings and directly integrated into pre-existing infrastructure. Micro-wind turbines are beneficial because it creates a sustainable form of power generation, reduces fossil fuel emissions, and is cost efficient due to the affordability and small size of the turbine (Dixon P. Drumheller, 2015).

## 2.2 DC Brushless motor

Conventional DC motors have traditionally been used in applications where DC power sources are available, such as on aircraft and automobiles. However, small DC motors of these types have a number of disadvantages. The principal disadvantage is excessive sparking and brush wear. Small, fast DC motors are too small to use compensating windings and interpoles, so armature reaction and  $L di/dt$  effects tend to produce sparking on their commutator brushes. In addition, the high rotational speed of these motors causes increased brush wear and requires regular maintenance every few thousand hours. If the motors must work in a low-pressure environment (such as at high altitudes in an aircraft), brush wear can be so bad that the brushes require replacement after less than an hour of operation (Chapman, 2012).

In some applications, the regular maintenance required by the brushes of these DC motors may be unacceptable. Consider, for example a DC motor in an artificial heart-regular maintenance would require opening the patient's chest. In other applications, the sparks at the brushes may create an explosion danger, or unacceptable RF noise. For all of these cases, there is a need for a small, fast DC motor that is highly reliable and has low noise and long life (Chapman, 2012).

Such motors have been developed in the last 25 years by combining a small motor much like a permanent magnet stepper motor with a rotor position sensor and a solid-state electronic switching circuit. These motors are called brushless DC motors because they run from a DC power source, but do not have commutators and brushes. A sketch of a small brushless dc motor is shown in figure 2.1, and figure 2.2 shows voltage pulse. The rotor is similar to that of a permanent magnet stepper motor, except that it is nonsalient. The stator can have three or more phases and the figure 2.1 shows an example of four phases (Chapman, 2012). . The inputs to the control unit consist of a DC power source and a signal proportional to the current motor position.

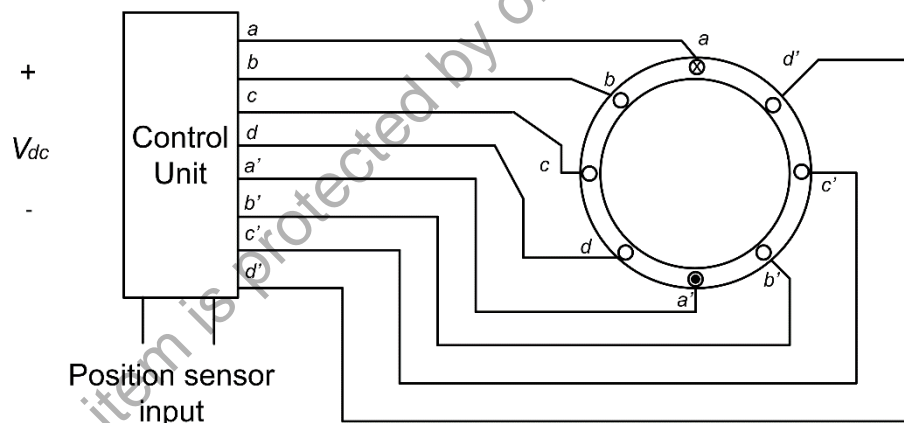

Figure 2.1: The figure shows a brushless DC motor and its associated control unit.

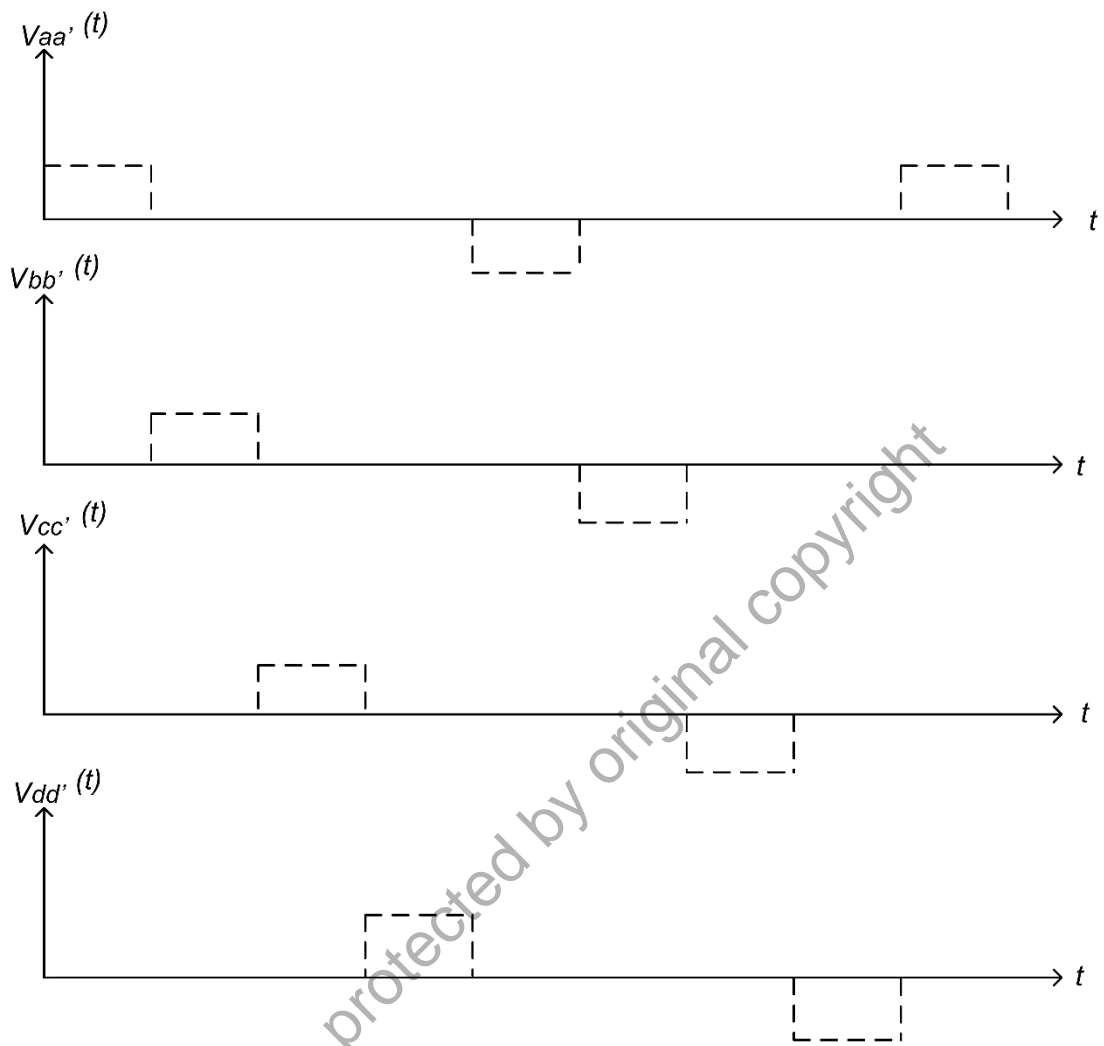

Figure 2.2: A voltages applied to the stator coils.

### 2.2.1 Basic Components of DC Brushless Motor

The basic components of a brushless de motor are:

- a) A permanent magnet rotor
- b) A stator with a three, four or more phase winding.
- c) A rotor position sensor.