



**MAXIMUM POWER POINT TRACKING (MPPT)  
ALGORITHM FOR PHOTOVOLTAIC (PV)  
SYSTEM BASED ON PARABOLIC PREDICTION  
METHOD**

by

**HUSSEIN ALI MOHAMMED SHUTARI  
(1732222327)**

A dissertation submitted in fulfillment of the requirements for the degree of  
Master of Science (Electrical Power Engineering)

**School of Electrical System Engineering  
UNIVERSITI MALAYSIA PERLIS**

2018

UNIVERSITI MALAYSIA PERLIS

DECLARATION OF DISSERTATION

Author's Full Name : HUSSEIN ALI MOHAMMED SHUTARI  
Title : MAXIMUM POWER POINT TRACKING (MPPT)  
ALGORITHM FOR PHOTOVOLTAIC (PV) SYSTEM  
BASED ON PARABOLIC PREDICTION METHOD  
Date of Birth : 22 MARCH 1987  
Academic Session : 2017/2018

I hereby declare that this dissertation becomes the property of Universiti Malaysia Perlis (UniMAP) and to be placed at the library of UniMAP. This dissertation is classified as:

- CONFIDENTIAL** (Contains confidential information under the Official Secret Act 1997) \*
- RESTRICTED** (Contains restricted information as specified by the organization where research was done) \*
- OPEN ACCESS** I agree that my dissertation to be published as online open access (Full Text)

I, the author, give permission to reproduce this dissertation in whole or in part for the purpose of research or academic exchange only (except during the period of \_\_\_\_\_ years, if so requested above)

Certified by:

  
\_\_\_\_\_  
**SIGNATURE**

\_\_\_\_\_  
**SIGNATURE OF SUPERVISOR**

07632276

DR. MOHAMMAD FARIDUN NAIM  
BIN TAJUDDIN

\_\_\_\_\_  
(NEW IC NO. /PASSPORT NO.)

\_\_\_\_\_  
NAME OF SUPERVISOR

\_\_\_\_\_  
Date: 06 August 2018

\_\_\_\_\_  
Date: 06 August 2018

## ACKNOWLEDGMENT

In the name of Allah, the Most Compassionate, the Most Merciful.

Firstly, (Alhamdulillah) all praise be upon Allah, Lord of the Universe for all blessings that He has given to us. And may His blessings, peace, and favours descend in perpetuity on our beloved Prophet Muhammad (peace be upon him) who was sent as mercy to the entire world. Honestly, without his blessings, grace, and guidance, this research would not have seen the light of day. My wish is that this work will be beneficial to people who need it.

Secondly, this research would not finish without many people, I would like to express my deepest gratitude to my supervisor Dr. Mohammed Faridun bin Tajuddin for his guidance, support, dedication, constant feedback and commitment to develop this research from start to finish.

Thirdly, special appreciation and gratitude go to my brother Fekri Ali for his financial support. Also, my beloved family for their unwavering support and encouragement without their prayers and support, I surely would not have endured the hardships and completed this task successfully. Not forgetting Azrilmukmin Azmi for his guidance from the first day of the research. Once again, thanks to all for the unforgettable support.

Furthermore, I would like to thank other lecturers from the School of Electrical System Engineering for their cooperation and advise that contributed to the completion of this dissertation. I am also grateful to University Malaysia Perlis (UniMAP), especially the School of Electrical Systems for providing me with an exciting opportunity to learn and advance my knowledge and creativity.

Lastly, I am indebted to all my seniors and friends for sharing their experiences and enriching the educational experience. They provided me with the encouragement and support to complete the project. I am truly blessed to have such friends.

## TABLE OF CONTENTS

	<b>PAGE</b>
<b>DECLARATION OF DISSERTATION</b>	<b>i</b>
<b>TABLE OF CONTENTS</b>	<b>iii</b>
<b>LIST OF TABLES</b>	<b>vi</b>
<b>LIST OF FIGURES</b>	<b>vii</b>
<b>LIST OF ABBREVIATIONS</b>	<b>xi</b>
<b>LIST OF SYMBOLS</b>	<b>xii</b>
<b>ABSTRAK</b>	<b>xiii</b>
<b>ABSTRACT</b>	<b>xiv</b>
<b>CHAPTER 1 INTRODUCTION</b>	<b>1</b>
1.1 Background	1
1.2 Problem Statement	3
1.3 Objectives	4
1.4 Scope of the Work	5
1.5 Dissertation Organisation	6
<b>CHAPTER 2 LITERATURE REVIEW</b>	<b>8</b>
2.1 Introduction	8
2.2 Maximum Power Point Tracking Methods	9
2.3 Conventional MPPT Methods	10
2.3.1 Fractional Open-Circuit Voltage	10
2.3.2 Fractional Short-Circuit Current	12
2.3.3 Perturb and Observe (P&O)	13
2.3.4 Incremental Conductance	16

2.4	Soft Computing Methods	19
2.4.1	Fuzzy Logic Control (FLC)	19
2.4.2	Artificial Neural Network (ANN)	22
2.5	Parabolic method.	24
2.6	Summary	27
<b>CHAPTER 3 METHODOLOGY</b>		<b>28</b>
3.1	Introduction	28
3.2	Photovoltaic Power Generation (PV Array)	30
3.2.1	Mathematical Model of PV Module	30
3.2.2	Output Characteristics of PV Module	32
3.3	DC-DC Buck Converter Analysis and Design	35
3.3.1	Inductor Current Analysis	36
3.3.2	Capacitor Analysis in CCM	40
3.3.3	Capacitor Current	40
3.3.4	Ripple Voltage	41
3.3.5	DC-DC Buck Converter Design	42
3.4	The Proposed MPPT Algorithm	43
3.5	Basic Mathematical Theory on Parabolic Function	44
3.5.1	MPPT Algorithm Based on Parabolic Prediction Method	45
3.5.2	Convergence System of the Proposed Method	49
3.5.3	Dynamic Response to Variations in Irradiance	51
3.6	MATLAB Simulation	53
3.6.1	PV Array Simulation	53
3.6.2	The DC-DC Buck Converter Simulation	54
3.6.3	MPPT Block Simulation	55
3.7	Summary	56
<b>CHAPTER 4 RESULTS &amp; DISCUSSION</b>		<b>57</b>

4.1	Introduction	57
4.2	DC-DC Buck Converter Analysis	57
4.3	The Proposed MPPT Algorithm Performance	58
4.3.1	MPPT Performance During Steady State Condition	59
4.3.2	Performance MPPT Algorithm at Dynamic Change in Irradiance Condition	69
4.4	Summary	78
<b>CHAPTER 5 CONCLUSION</b>		<b>79</b>
5.1	Summary of the work	79
<b>REFERENCES</b>		<b>81</b>
<b>APPENDIX A</b>		<b>89</b>
<b>Appendix A-1. Data Sheet of Solar Panel</b>		<b>89</b>
<b>Appendix A-2. Data Sheet of Solar Panel</b>		<b>90</b>
<b>APPENDIX B</b>		<b>91</b>
<b>APPENDIX B 1. Irradiance of 1000W/m<sup>2</sup></b>		<b>91</b>
<b>APPENDIX B 2. Irradiance of 900W/m<sup>2</sup>.</b>		<b>92</b>
<b>APPENDIX B 3. Irradiance of 800W/m<sup>2</sup>.</b>		<b>93</b>
<b>APPENDIX B 4. Irradiance of 700W/m<sup>2</sup>.</b>		<b>94</b>
<b>APPENDIX B 5. Irradiance of 600W/m<sup>2</sup>.</b>		<b>95</b>
<b>APPENDIX B 6. Irradiance of 500W/m<sup>2</sup>.</b>		<b>96</b>
<b>APPENDIX B 7. Irradiance of 400W/m<sup>2</sup>.</b>		<b>97</b>
<b>APPENDIX B 8. Irradiance of 300w/m<sup>2</sup>.</b>		<b>98</b>
<b>APPENDIX B 9. Irradiance of 200w/m<sup>2</sup>.</b>		<b>99</b>
<b>APPENDIX B 10. Irradiance of 100W/m<sup>2</sup>.</b>		<b>100</b>

## LIST OF TABLES

	<b>PAGE</b>	
Table 2.1	Summary of works related to the P&O method	15
Table 2.2	Summary of works that used the incremental conductance method	19
Table 2.3	Rule-based table of MPPT for seven fuzzy subsets	22
Table 2.4	Summary of work on FLC and ANN based MPPT methods	24
Table 2.5	Summary of previous works related to parabolic method	26
Table 3.1	Parameters of the DC-DC Buck Converter	43
Table 3.2	Specification of JWP 250W DESERT module and array	54
Table 4.1	Experimental results of DC-DC buck converter	58
Table 4.2	Comparison tracking results of the proposed and conventional P&O methods	69
Table 4.3	Comparison tracking results of proposed and conventional P&O methods under a dynamic change in irradiance by a step change of $200\text{W}/\text{m}^2$	72
Table 4.4	Comparison tracking results of proposed and conventional P&O methods under a dynamic change in irradiance by a step change of $100\text{W}/\text{m}^2$	74

## LIST OF FIGURES

	<b>PAGE</b>	
Figure 2.1	Block diagram of the PV system with MPPT controller	8
Figure 2.2	Flowchart of fractional open-circuit voltage	11
Figure 2.3	Flowchart of fractional short-circuit current method	13
Figure 2.4	Oscillation operating point around MPP.	14
Figure 2.5	Typical flowchart of the P&O method	14
Figure 2.6	Flowchart of the incremental conductance method	18
Figure 2.7	Characteristic of the P-V curve for the incremental conductance method	18
Figure 2.8	Structure of fuzzy logic control	21
Figure 2.9	Membership function of I/O of the fuzzy logic controller	22
Figure 2.10	Neural network structure with three layers	23
Figure 2.11	Selecting three points with the best estimation	25
Figure 3.1	Block diagram of the PV system	28
Figure 3.2	Flowchart of the proposed method	29
Figure 3.3	Equivalent circuit of a solar cell	30
Figure 3.4	PV cell, module and array	32
Figure 3.5	P-V curves for different irradiances	33
Figure 3.6	I-V curves for different irradiances	33
Figure 3.7	P-V curves for different temperatures	34
Figure 3.8	I-V curves for different temperatures	34



Figure 3.9	Configurations of a DC-DC buck converter in the ON state	35
Figure 3.10	Configurations of DC-DC buck converter of the OFF state	36
Figure 3.11	Waveform associates with Buck converter in CCM mode. (A) is Switch state (B) inductor voltage and (C) inductor current.	37
Figure 3.12	Symmetry axis of standard and vertex forms of the parabolic function	44
Figure 3.13	Output power approximated by a parabolic curve	46
Figure 3.15	Finding the maximum power from three given points	48
Figure 3.14	Flowchart of the proposed method	49
Figure 3.16	Shifting of the duty cycle to the right for convergence	50
Figure 3.17	Shifting of the duty cycle to the left for convergence	50
Figure 3.18	(a) Change in irradiance from low to high, (b) Change in irradiance from high to low	51
Figure 3.19	Rearrangement of duty cycle after the measured power points became to the left due to the change in irradiation	52
Figure 3.20	Rearrangement of duty cycle after the measured power points became to the right due to the change in irradiation	52
Figure 3.21	Modelling system through Simulink environment	53
Figure 3.22	Simulink model of PV array	54
Figure 3.23	Overview of the DC-DC buck converter model in Simulink	55
Figure 3.24	Simulink model of the MPPT controller	55
Figure 4.1	Tracking the performance of the proposed method at irradiance $1000\text{W}/\text{m}^2$	59

Figure 4.2	Tracking the performance of the conventional P&O method at 1000W/m <sup>2</sup>	60
Figure 4.3	Tracking the performance of the proposed method at irradiance 900w/m <sup>2</sup>	61
Figure 4.4	Tracking the performance of the conventional P&O method at 900W/m <sup>2</sup>	61
Figure 4.5	Tracking the performance of the proposed method at irradiance 800W/m <sup>2</sup>	62
Figure 4.6	Tracking the performance of the conventional P&O method at 800W/m <sup>2</sup>	63
Figure 4.7	Tracking the performance of the proposed method at irradiance 600w/m <sup>2</sup>	64
Figure 4.8	Tracking the performance of the conventional P&O method at 600W/m <sup>2</sup>	65
Figure 4.9	Tracking the performance of the proposed method at irradiance 400w/m <sup>2</sup>	66
Figure 4.10	Tracking the performance of the conventional P&O method at 400W/m <sup>2</sup>	66
Figure 4.11	Tracking the performance of the proposed method at irradiance 200w/m <sup>2</sup>	67
Figure 4.12	Tracking the performance of the conventional P&O method at 200W/m <sup>2</sup>	68
Figure 4.13	Tracking the performance of the proposed method under a dynamic change in irradiance by step-up change of 200 W/m <sup>2</sup>	70
Figure 4.14	Tracking the performance of conventional P&O method under a dynamic change in irradiance by step -up change of 200W/m <sup>2</sup>	71

Figure 4.15	Tracking the performance of the proposed method under dynamic change in irradiance by step -up change of $100\text{W}/\text{m}^2$	73
Figure 4.16	Tracking the performance of conventional P&O method under dynamic change in irradiance by step -up change of $100\text{W}/\text{m}^2$	73
Figure 4.17	Tracking the performance of the proposed method under a dynamic change in irradiance by step-down change of $200\text{W}/\text{m}^2$	75
Figure 4.18	Tracking the performance of the conventional P&O method under a dynamic change in irradiance by step-down change of $100\text{W}/\text{m}^2$	75
Figure 4.19	Step-up and step-down rapidly change in irradiances	76
Figure 4.20	Tracking the performance of the proposed method at multi-step change	77
Figure 4.21	Tracking the performance of the at conventional P&O multi-step change in irradiance	77

## LIST OF ABBREVIATIONS

ANN	Artificial Neural Network
CCM	Continuous Conduction Mode
D	Duty cycle
Inc cod	Incremental Conductance
$I_{PV}$	Photovoltaic Current
MATLAB	Matrix Laboratory
MPP	Maximum Power Point
MPPT	Maximum power point tracking
P&O	Perturbation and observation method
$R_S$	Series Resistances
$R_{sh}$	Shunt Resistances
$P_{PV}$	Photovoltaic Power
$V_{PV}$	Photovoltaic Voltage
FLC	Fuzzy Logic Control
$V_{ref}$	Voltage Reference

©This item is protected by original copyright

## LIST OF SYMBOLS

P	Parallel
S	Series
I	Current
V	Voltage
D	Duty cycle

©This item is protected by original copyright

## **Algoritma pengesanan titik kuasa maksimum (MPPT) untuk sistem photovoltaic (PV) berasaskan kaedah ramalan parabola**

### **ABSTRAK**

Peningkatan penggunaan tenaga elektrik dalam dekad-dekad kebelakangan ini telah mendorong pencarian sumber tenaga lain. Salah satu daripada sumber ini ialah tenaga suria. Sistem fotovoltan (PV) adalah pendekatan strategik untuk mengeksploitasi tenaga solar. Walau bagaimanapun, kelemahan modul PV adalah kecekapan penukaran yang rendah, ciri tidak linear dan kebergantungan pada suhu dan jumlah sinaran. Teknik pengesanan titik kuasa maksimum (MPPT) adalah penyelesaian praktikal untuk memaksimumkan pengeluaran sistem PV dan mengatasi ciri-ciri tidak linear dalam semua keadaan. Banyak algoritma MPPT telah dicadangkan. Kebanyakan algoritma MPPT mengalami masalah ayunan di mana titik operasi berayun di sekitar titik kuasa maksimum. Akibatnya, kehilangan kuasa meningkat. Kehilangan pengesanan di bawah perubahan dinamik dalam sinaran adalah satu lagi cabaran dalam MPPT. Dalam kerja ini, algoritma MPPT baru berdasarkan Kaedah Ramalan Parabola dicadangkan untuk menjejaki titik kuasa maksima. Kaedah yang dicadangkan dapat mengatasi keterbatasan algoritma MPPT konvensional seperti ayunan keadaan mantap dan kehilangan pengesanan semasa perubahan dinamik dalam sinaran. Prinsip kerja kaedah ini adalah pengiraan kuasa maksimum dari fungsi cembung parabola. Selanjutnya, skema kaedah asas adalah canggih untuk mengawal kecengkungan dan rantau optimum parabola anggaran untuk menjamin penumpuan berulang algoritma yang dicadangkan. Untuk mengesahkan keunggulannya, kaedah yang dicadangkan dibandingkan dengan kaedah P&O konvensional dari segi keadaan mantap dan perubahan dinamik dalam keadaan sinaran. Algoritma ini dilakukan pada penokar arus terus. Pengesanan kaedah yang dicadangkan telah dilakukan menggunakan MATLAB / Simulink. Hasilnya membuktikan bahawa algoritma MPPT yang dicadangkan menjejaki kuasa maksimum dengan jayanya dalam masa yang singkat yang kurang daripada kaedah P&O konvensional. Selain itu, kaedah yang dicadangkan mempunyai tindak balas dinamik yang lebih cepat dan menghilangkan ayunan pada titik operasi di sekitar titik kuasa maksimum (MPP) di bawah keadaan keadaan mantap. Dalam perubahan dinamik dalam sinaran, algoritma MPPT memerlukan kurang daripada 100 mili saat untuk mencapai kuasa maksimum baru berbanding dengan algoritma P&O konvensional yang memerlukan lebih daripada 100 mili saat. Untuk semua ujian kes, algoritma yang dicadangkan mempunyai ayunan sifar selepas mencapai titik maksimum berbanding dengan algoritma P&O konvensional yang berterusan berayun walaupun selepas mencapai kuasa maksimum.

## Maximum Power Point Tracking (MPPT) Algorithm for Photovoltaic (PV) System Based on Parabolic Prediction Method

### ABSTRACT

The increased consumption of electric energy during the recent decades has prompted a search for other sources of energy. One of these sources is solar energy. Photovoltaic (PV) systems are a strategic approach to exploiting the solar energy. However, the harvesting energy of the PV module is low conversion efficiency, nonlinear characteristics and dependent on the temperature and the amount of irradiance. Maximum power point tracking (MPPT) techniques are a practical solution to maximise the output of the PV system and overcome nonlinear characteristics under all circumstances. Many MPPT algorithms have been proposed. Most MPPT algorithms suffer from oscillation where the operation points oscillate around the maximum power point. As a result, the loss of power is increased. The loss of tracking under a dynamic change in irradiance is another challenge in MPPT. In this work, a new MPPT algorithm based on the Parabolic Prediction Method is proposed to track the maximum power point. The proposed method can overcome the limitation of conventional MPPT algorithms such as steady state oscillation and loss of tracking during a dynamic change in irradiance. The working principle of this method is the calculation of the maximum power from a parabolic convex function. Subsequently, a methodical scheme is sophisticated to regulate the concavity and optimum region of the approximate parabola for guaranteeing the repetitive convergence of the proposed algorithm. To validate its superiority, the proposed method is compared with the conventional P&O method in terms of steady state and dynamic change in irradiance conditions. The algorithm is carried out on a DC-DC buck converter. The verification of the proposed method has been done using MATLAB/Simulink®. The results prove that the proposed MPPT algorithm tracks the maximum power successfully within a short time of 100 ms that is less than the conventional P&O method. Besides that, the proposed method has a faster dynamic response and removes oscillations of the operating point around the maximum power point (MPP) under steady state conditions. In a dynamic change in irradiance, the MPPT algorithm needs less than 100msec to reach the new maximum power compared to the conventional P&O algorithm that needs more than 100msec. For all case tests, the proposed algorithm has zero oscillation after reaching the maximum compared to the conventional P&O algorithm that continues in oscillation even after reaching maximum power.

# CHAPTER 1

## INTRODUCTION

### 1.1 Background

Global electricity needs have increased significantly over the past few decades. Demand is anticipated to grow further due to population growth and modern lifestyles that are integrated with high levels of technology use. Furthermore, the industrial and technological revolutions have changed modern living and are fuelled by power consumption. Furthermore, fears of declining fossil fuels and environmental damage have brought about a global push to alternative sources of power. Irrespective of the effects of environmental pollution due to the use of conventional fossil fuel, global climate change has contributed to the problem of oil scarcity (Sebri & Ben-Salha, 2014).

Due to the reasons mentioned above, researchers and world communities are preparing to face these challenges and find alternative sources of energy. Renewable energy is one of the alternative resources used to meet energy requirements. Solar energy is one of the best renewable energies to enhance other energy resources such as wind, rain, tides, waves, and geothermal heat to reduce the use and dependence on fossil fuel. Using clean energy like solar instead of using fossil fuel decreases the effects of CO<sub>2</sub>, environmental pollution and global warming (Chauhan & Saini, 2014).

Photovoltaic technology is one of the best ways to benefit from solar energy and convert sunlight energy into electrical energy using solar cells which is called the PV



effect. The name 'photovoltaic' comes from the process of converting sunlight (photons) directly into electricity (voltage.) (Parida, Iniyar, & Goic, 2011). Nowadays, many countries are using photovoltaic systems in several areas as the most comfortable solution for electricity demand despite its low efficiency and high initial cost (Salas & Olias, 2009).

The photovoltaic system has two main limitations. The first is that the PV system depends on weather conditions like varied temperature and amount of irradiance. The second is that the energy conversion efficiency of the PV module is low. Studies show that solar cells convert 20% of sunlight energy into electrical energy (Yalçın & Öztürk, 2013).

Researchers are in the process of improving PV system technology to increase its efficiency and reduce costs. Some improvements include installing controllers and sensors for the PV system to track the sun's position and orientate a solar panel with the movement of the sun to concentrate the sunlight on the solar panel. These improvements are not enough to overcome the limitations of the PV system. Therefore, the maximum power point tracking techniques are also used to decrease the cost and improve the efficiency of the PV system (Aribisala, 2013).

To date, photovoltaic efficiency depends on the efficiency of the PV module, converter/inverter, and maximum power point tracking technique (MPPT) technique. It is not easy to improve the PV module and converter/inverter because they depend on the available hardware, whereas it is much easier to improve the MPPT techniques. Several MPPT techniques are currently being improved.

The MPPT is a suitable algorithm that is included in a conversion power device to extract the maximum power from the PV array under all environmental circumstances in order to make the PV system operate at its maximum potential.

The unique point at which the power output of the PV panel is at its maximum is called the maximum power point (MPP). MPP is not constant but changes depending on the weather conditions such as the amount of irradiance and ambient temperature. Many MPPT techniques have been presented and applied. If the MPPT algorithm can adjust its operating point corresponding to MPP, it is considered an efficient system (Dawoud, Amer, & Gross, 2007).

This work is carried out by a new proposed MPPT algorithm based on the parabolic prediction method. It first uses three duty cycles and their corresponding power to define the parabola curve. Next, the parabolic function is utilised to find the maximum duty cycle at the curve. The maximum duty cycle is applied to extract its corresponding maximum power from the PV array. A DC-DC buck converter will be used. This MPPT algorithm incorporates the tracking of the maximum power in terms of dynamic and steady-state conditions.

## **1.2 Problem Statement**

The output characteristics of the photovoltaic array are nonlinear. It presents nonlinear I-V and P-V curves. On the P-V curve is a unique point which is the maximum value. This point is called the maximum power point (MPP). The highest power can be extracted from the PV array when the operating point of the system is at MPP. The MPP

is not constant at all times and varies with the amount of irradiance and temperature. Therefore, there is a need to track the MPP permanently and justify the operating point of the PV system corresponding to the MPP. This task can be achieved using MPPT algorithms. Although many MPPT algorithms have been used for this purpose, some can only track the maximum power point (MPP) under uniform irradiance where only a unique MPP exists in the P-V curve. Also, most MPPT algorithms have the problem of oscillation where the operation points oscillate around the maximum power point. This increases the loss of power. The loss of tracking under a dynamic change in irradiance is another challenge in MPPT. This means that the amount extracted from the PV array is much lower than the available power generated by the array. Therefore, there is a need to optimise the PV system power generation by using an accurate MPPT algorithm in the composition of the DC-DC converter.

### **1.3 Objectives**

The main objectives of this work are as follows:

- (i) To select suitable DC-DC Buck converter parameters for MPPT application.
- (ii) To develop an MPPT algorithm based on the parabolic prediction method.
- (iii) To simulate and analyse the performance of the proposed MPPT algorithm under a static and dynamic change in irradiance conditions in terms of tracking efficiency.

## 1.4 Scope of the Work

The main scope that will be accomplished in this work is summarised as follows:

- (i) MATLAB/Simulink<sup>®</sup> 2017a is employed to simulate the components of the PV system. The modelled system consists of a PV array, DC-DC buck converter, and MPPT algorithm. The PV array consists of four solar panels which are connected in  $2 \times 2$  ( $S \times P$ ) configurations.
- (ii) A basic DC-DC buck converter is utilised for power conversion. The buck converter is analysed to evaluate its performance in order to integrate it with the MPPT controller.
- (iii) The validation of the MPPT algorithm based on the proposed method is performed under a steady state and dynamic change in irradiance conditions to evaluate its tracking efficiency and speed. Besides that, the MPPT algorithm performance is evaluated in terms of eliminating steady-state oscillation and the probability of deviation from the MPP position.
- (iv) For all tests, the proposed method is compared with the conventional P&O based MPPT to prove its effectiveness. The primary analysis focuses on the time spent to reach the MPP, number of iterations and the amount of extracted power from the PV array.

- (iiv) The partial shading condition is not addressed in this work. The MPPT algorithm based on the proposed method fails to track the MPP when the partial shading occurrence. This is because of its working principle.

## **1.5 Dissertation Organisation**

The contents of this dissertation are organised into five chapters. Chapter one introduces the idea of renewable energy and how it contributes to meeting the increasing demand for electricity, in particular, the photovoltaic system. It then explains the nonlinear problem of the output characteristic of the photovoltaic array which leads researchers to find a solution to dealing with the nonlinear problem. The chapter then explains the use of maximum power point tracking techniques to increase the efficiency of the PV system. The principal objectives, organisation, and scope of this dissertation are also detailed.

Chapter two reviews the literature on the methods used commonly in the field of MPPT. The MPPT techniques can be categorised into conventional techniques and soft computing techniques, where conventional techniques include open-circuit voltage, short-circuit current, perturbation, and observation (O&P) and incremental conductance (Inc Cond) methods that are used in large or medium power capacity photovoltaic (PV) systems. Soft computing techniques include fuzzy logic control and artificial neural network. The differences between the conventional and soft computing techniques are also described.

In chapter three details the methodology of this project. The design and simulation of power electronic DC-DC Buck converter along with maximum power point tracking (MPPT) algorithm for the PV system based on parabolic prediction method will be performed. Next, chapter four analyses the experimental results from a simulation using MATLAB/Simulink®. The research concludes in chapter five.

©This item is protected by original copyright

## CHAPTER 2

### LITERATURE REVIEW

#### 2.1 Introduction

The MPPT algorithms are essential in the PV system because the MPP of a PV array changes along with irradiance and temperature. This means that the use of MPPT algorithms are required to obtain the maximum power from the PV array. Figure 2.1 shows the proposed system of this work that consists of three main components namely the solar station, DC-DC buck converter and the MPPT controller that includes the proposed algorithm. Over the past years, several methods to track the MPP have been established and published. These methods differ in convergence speed, cost, required sensors, complexity, tracking when irradiation or temperature change, the range of effectiveness, and the hardware required for the implementation among others (Morales, 2010).

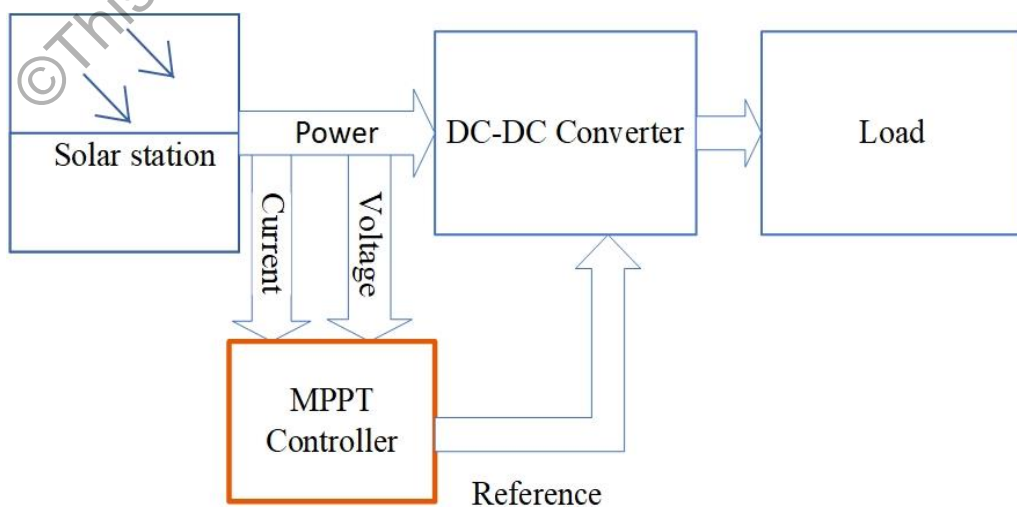

Figure 2.1 Block diagram of the PV system with MPPT controller

## 2.2 Maximum Power Point Tracking Methods

Maximum power point tracking methods are categorised into two categories (Garg, 2014). The first category is based on the conventional approach. The second category is based on the soft computing approach. The conventional methods are easy to implement, cheap and most widely used in commercial products. The soft computing techniques are complex structures but have more efficient and faster responses than conventional techniques.

Approximately 40 (Verma, Nema, Shandilya, & Dash, 2016) conventional and soft computing methods are presented in the literature until 2016. Some of them are similar to each other and share operating principles. In this work, the most commonly used methods of both categories are discussed. The principle of the methods and a summary of works related to the methods as used in the practical environment are presented and explained. The most common conventional and soft computing maximum power point tracking (MPPT) methods are listed as follows:

### **Conventional methods are:**

- (i) Fractional open-circuit method (Ahmad, 2010)
- (ii) Fractional short-circuit current method (Sher, Member, et al., 2015)
- (iii) Perturbative and observe(P&O) method (Atallah, Abdelaziz, & Jumaah, 2014)
- (iv) Incremental conductance method (Chafle & Vaidya, 2013)