

Reduction of Electrical Stresses in Grid Micro Inverter through Semiconductor Switches

Mohsin Tahir^{1*}, Sheeraz Ahmed², Shayan Tariq³, Asif Nawaz⁴, Shahid Latif⁵, Atif Ishtiaq⁶

^{1,2,3,5,6}Iqra National University Peshawar, Pakistan

⁴Higher Colleges of Technology, Women Campus, Dubai, UAE

Received 14 September 2021, Revised 28 December 2021, Accepted 9 January 2022

ABSTRACT

Micro inverters are power electronics devices integrated close to photovoltaic (PV) panels. PVs produced today could make 92% of its rated power. With the passage of time, the reliability and performance of micro inverter needs to be redesigned to operate under harsh temperature conditions. This paper presents the distribution of electrical and thermal stresses that occur in semiconductor devices of micro inverters. H5 micro inverter topology is simulated and analyzed as a benchmark of losses in devices of PVs. The performance of micro inverter is evaluated on the basis of conduction and switching losses in basic and distributed micro inverters using simulation tool PSIM. H5 inverter single switch conduction losses came out to be in the range of 6 W while the switching losses were about 0.12 W. Net conduction losses of the inverter were 24.2 W while the switching losses were 0.483 W. For modified inverter as well as auxiliary, single switch had conduction losses in the range of 1.64 W while the total conduction losses for individual switching segment were 13.22 W which are almost half of H5 losses. Results revealed that it has a significant impact on the micro inverter which is replaced with distributed components in this design and has a remarkable improvement. The conduction losses are reduced to 73% and that of switching losses are reduced to 58.4%; leading to major contribution in designing cost effective and safe applications for micro inverters.

Keywords: Electrical and thermal stress, Micro inverter, PV life span, Semiconductor switches

1. INTRODUCTION

Photovoltaic (PV) is envisioned as a key source for the future energy mix and the cost of a module have been reduced promptly in the last 10 years and now, photovoltaic energy plants with megawatt capability are common all around the world. But still, as compared to other fossil fuels, per watt cost of solar PV is still expensive. This is just because the capital cost and investment of this is much more than the previous. There is a wide range of research and development around the world conducted to increase and enhance the efficiency of the photovoltaic energy and performance of the solar cell. The most economical way for the increment of PV installation performance is to consider the balance of the system with the help of power inverters.

Maximum power point tracking (MPPT) algorithm is the best improvement area to boost the efficiency. The MPPT comprises of the software's codes which can be rooted within the firmware of the power inverter [13]. To accomplish the maximum power point, MPPT automatically locates it with maximum power point operating voltage (VMP) or maximum power point operating current (IMP).

*Corresponding author: mohsintahir85@gmail.com

In recent applications such as a follow-up of the “maximum power point” (MPP) for PV energy, converters are required to operate and function in asymmetric conditions, because of the difference in source and loads of each converter. Ripples reduction is also an important feature for dual phase switching converters because it allows interleaving of phases for each converter to operate at higher ripple. This can be achieved by the lower values of the inductors and capacitors and approach in reduction of cost and size of the converter [7].

Due to the immense growth of energy consumption in all top-tiers and low-tiers fields of life, the conventional power generation resources are not capable to fulfill the load demand; renewable energy resources are overtaking the conventional energy resources. Among all the renewable energy resources, photovoltaic technology is one of the fastest trends all over the world due to its unlimited availability and low operational cost. Unlike conventional power generators, photovoltaic generators produce DC power which is unable to entertain AC load, but this problem has been rectified by power electronic inverters which convert DC into AC.

1.1 Basic Types of Micro Inverter

There is sharp focus on green and sustainable energy technologies such as solar photovoltaic because of environmental concern and the nonrenewable nature of fossil fuels. Photovoltaic installation has grown at every level like commercial, residential and utility; micro-inverters are the most popular way to approach grid integration at the residential level. The output of photovoltaic panel is in DC current form while most of our appliances are designed for AC current. For this purpose, we need an interface between AC loads and DC current of the PV panel. This interface is where inverter comes in action. In the last ten years, the photovoltaic energy is grown by 35% to 40% and reached to the record high world market of installation as much as 18.5GW in 2019 in which grid integrated systems are the largest [17].

Grid tied inverters are one of the major components of the photovoltaic systems and are categorized into three main categories:

- Micro-inverter
- Centralized inverter
- String inverter

Micro-inverters are the one whose power ranges from 150W to 300W that become trends for upcoming PV systems development which includes:

1. Modular design
2. Ease of expandability
3. Plug-and-Play
4. Lower installation costs operation
5. Improved energy harvest

However, many challenges remain in order to achieve low manufacturing cost, high conversion efficiencies, and prolong life span. Since micro-inverters are typically placed behind the PV panel and may well be integrated on the PV panel's back casing, having an inverter lifespan which matches PV panel's life is a major design consideration. For applications whose power level is under several kilowatts, the single-phase connection is commonly used in the system. Though, single phase connection has the disadvantage that the power flow to the grid is time variable, while the power of the PV panel must be persistent for the maximum energy harvest, which results in instantaneous input power discrepancy with the output instantaneous alternating current power to the grid. Therefore, active energy storage elements should be placed between the input and output to balance the power conditions (decouple the unbalance conditions). Basically, capacitor is used to assist as a power decoupling element. However, the lifetime of

different types of capacitors varies, e.g., electrolytic capacitors typically have a partial lifetime, namely 1000~7000 hours at 105°C operating temperature [9].

The growth of solar energy has been remarkable over the past few years. This remarkable growth has been majorly influenced by the declining cost of photovoltaic modules. With years of research and development, the global average price of photovoltaic (PV) module is now less than \$0.70/watt. However, one of the major concerns for the future of the PV industry is the reliability of the PV system, inclusive of PV modules, interconnects the inverter system, the grid connection and the mounting systems. Modern commercial PV module manufacturers typically provide 25 years of warranty and claim 1% power degradation per year [12]. However, the system is only good as its weakest link and the reliability of the inverter system in particular is of high concern. One of the major concerns in today's world is global warming. The consequences of global warming are evident in the global temperature rise, sea level rise, climate change and frequent extreme weather conditions. Greenhouse gas is the primary contributor to global warming as more than 80% of the greenhouse gas emission is produced by the burning of fossil fuels. Renewable sources supplied about 11% of the total energy consumption globally in the year 2016 and contribute 19% towards global electricity generation. Hydro, solar, wind, biomass, ocean and geothermal energy are commonly considered as viable sources of renewable energy [5]. The total consumption of renewable energy sources is relatively small compared to fossil fuel energy source consumption as shown in Figure 1.

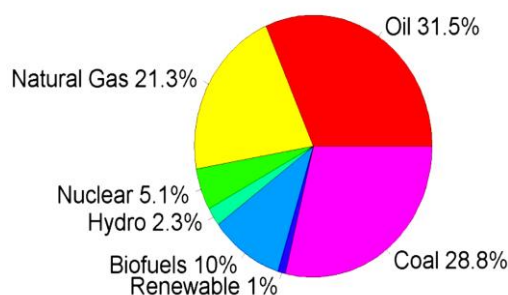

Figure 1. World renewable energy consumption [5]

According to Institute of Energy Association estimation, the growing global PV capacity will reach up to 3000 GW by 2050 which meets 11% of demand for global electricity. A complete PV system consists of several sub-systems. The first subsystem is for power generation, consisting of: PV cells, modules and arrays. PV arrays are created by interconnecting a large number of PV modules with each other [13]. The second sub-system is the interconnected and PV wire system. Depending upon the inverter system, the interconnected system can be in series or parallel. The final subsystem is the PV inverter system. The output of a PV module or array is DC power. Therefore, in demand to connect to the grid or directly to common household appliances, the DC power must be converted to utility frequency AC power. The integration of PV panels to the string inverter and its connections to the micro inverter is shown in Figure 2.

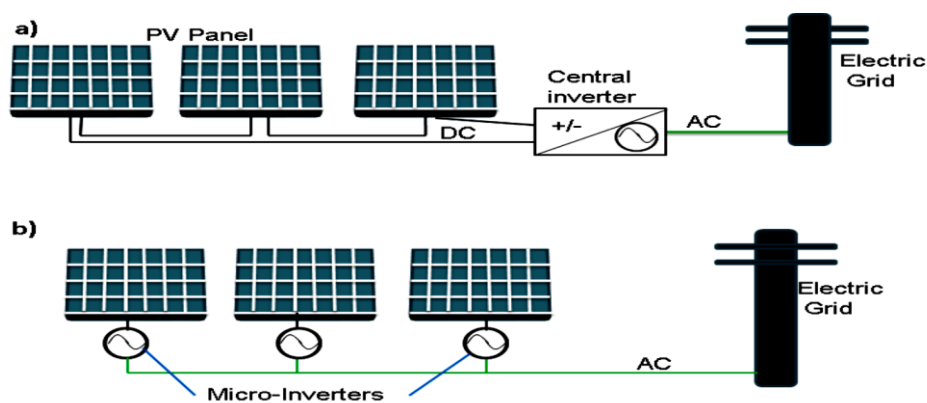

Figure 2. String and micro inverter connected to electric grid

1.2 Comparison of Micro Inverter and String Inverter

A solar micro-inverter or simply micro inverter is a plug-and-play device used in photovoltaic that converts DC produced by a single solar module to AC. The output generated from different micro inverters can be combined and fed to the electrical grid micro inverters diverge with conventional string and central solar inverters which are further connected to multiple solar modules/panels of the photovoltaic system [1].

Micro inverters have several benefits over conventional inverters. The main advantage is that minor amounts of shading, debris or snow lines on any one solar module, or even a complete module failure, does not disproportionately reduce the output of the entire array. Each micro inverter harvests optimum power by performing maximum power point tracking (MPPT) for its connected module [4]. Simplified stock management, simplicity in system design, and lower amperage wires are other factors introduced with the micro inverter solution.

The main disadvantages of micro inverter include initial equipment cost per watt than equivalent power of the central inverter as each inverter need to get installed together to a panel (specially on roof). Few manufacturers have pointed out this issue with panels which has built-in micro inverters.

Micro-inverters some time called as Module Integrated Converters (MIC), have appeared to have high vitality yield photovoltaic (PV) system because of inverters for every specific PV module. Micro-inverters are introduced on the rooftop under or by a module and for the most part serve one single module at any given moment. Some serve two modules yet the twofold ones have not been as effective as the small scale inverters appended to a solitary module. Smaller scale inverters change over the DC of the modules into AC similarly as traditionally conspicuous inverters do and give most extreme power point [14].

Table 1 Comparison of string inverters and micro inverters [14]

| | String Inverters | Micro Inverters |
|--|--|---|
| Functions | Photovoltaic module is connected in parallel with one or two strings and further connected directly to string inverter for Direct Current to alternating current conversion. | Every Photovoltaic module has one micro inverter for direct current to alternating current conversion. In this type of modules shading impacts only individual module |
| Relevant product price | Low | High |
| Shading Performance | Poor | High |
| Module levels Monitoring | No | Yes |
| Divergence losses | Yes | No |
| Quantity of Electronics component | Normal | High |
| Installation Safety | Normal | Uses AC cables with no high voltage |

In Table 1, the basic difference of sting and micro inverter in terms of its functions, price, performance, losses and safety are discussed.

2. LITERATURE REVIEW

The author in [1] presented the isolated and non-isolated topologies of micro inverter and showed that the non-isolated topologies are more efficient and compact than isolated topologies. In [2], the author presented development and design of micro inverter system from commercial-ready prototype. Topology, power supplies, control, filter solutions and packaging are discussed. In [3], the author tested and compared the stresses of inverters with manufacturers and purchasers. In [4], the author calculated the mean time between failure of the micro inverter and the proposed model was determined in terms of the statistical distribution of electrical and thermal stresses in the aspect of environment volatility. In [5], the author presented the different pulse width modulation techniques of micro inverter in detail with the selection of suitable PWM schemes and plotted the harmonic amplitudes vs. amplitude index. In [6], the author proposed the PV conversion systems and discussed PV converter which are more practical for the grid connected systems.

In [7], the author investigated the single stage and two stage topology micro inverter and investigated it by gallium nitride devices and Nano crystalline core materials. In [8], the author designed bidirectional boost/buck dc-dc converter for reactive power support and achieving high step-up ratio by using coupled inductors and proposed control strategy of micro inverter. In [9], the author designed 5 levels of 4 switch micro inverter by using PWM and proved that implementations reduce losses by up to 39% compared to a conventional topology. The results show that the proposed design improves performance of the micro inverter. In [10], the electro thermal models are built for the most reliability-critical components, i.e., power semiconductor devices and capacitors. The Monte Carlo simulation and Weibull analysis are conducted to obtain the system wear-out failure probability over time and revealed that both the mission profile and the thermal cross-coupling effect have a significant impact on the prediction of system. In [11], the author applied a reliability-oriented design method for a grid-connected PV micro inverter to

achieve specific lifetime requirement. Reliability allocation is performed from system-level requirement to component-level reliability design target. In [16], a single-phase PV inverter under yearly operation is presented with analyses of the thermal loading and lifetime. In [15], the author presented topological structure and operational principle of the micro inverter and overviewed the topologies and reliability of the conventional and string micro inverters. The author in [17] evaluated wear out reliability and analysis of impedance source PV micro inverter. Firstly, the implementation of hardware was described and then, the experimental results of the 300W micro inverter with electro thermal designed models of semiconductors and capacitors is carried out with the consideration of power loss and temperature. Finally, a DC link capacitor is employed which results in a remarkable improvement of micro inverter.

Table 2 Critical review of previous research work on micro inverters

| Reference | Methodology | Parameters Addressed | Achievements | Deficiencies |
|-----------|--|--|--|--|
| Ref [1] | Experimental verification and analysis of Micro inverter topologies. | Efficiency, power density, reliability and cost. | Estimated efficiency and loss breakdown. | high efficiency, high power density, and low cost |
| Ref [2] | Two-stage high-efficiency micro-inverter system with grid Volt/VAR support functions is designed. | Good switching variation, inverter loss breakdown, efficiency and total system cost. | Various design Trade-offs such as topology, control, filter solutions, and power supplies, and mechanical packaging are provided. | Power density and Reliability. |
| Ref [3] | Comparative analysis of stresses and levels for accelerated testing of inverters. | Temperature, humidity and voltage bias effect of the inverters. | inconsistent quality of the Inverters and the durability of components leading to greater cost for the photovoltaic plant operator. | Design validation testing using realistic operation, environmental, and connection conditions, including under end-use field conditions with feedback for continuous improvements. |
| Ref [4] | Based on stress-factor reliability for calculating the mean time between failures (MTBF) of a photovoltaic module-integrated inverter. | Module temperature, Insulation level and efficacy. | The reliability Of six different candidate inverter topologies for a PV-MII, showing the impact of each component on the inverter reliability. | Smaller data set was considered and no focus on operating cost. |
| Ref [5] | An energetic self-control strategy for design and prototype realization of a plug-in hybrid electrical vehicle (PHEV), To analyze and optimize the power flux between the different parts. | State of charge (SOC), temperature, and sign of the current (charge or discharge current). | Validation and improvement in combustion-engine mode CEM , electric-vehicle mode EVM, start-and-stop mode SSM. | Onboard energy control strategy and cost optimization. |

| | | | | |
|----------|---|--|---|---|
| Ref [6] | Commercial and Industrial power semiconductor modules for grid connected micro inverter. | High Power density, installation cost, minimization of leakage current. | Micro inverter system configuration, economic cost, reliability, high efficiency. | Residential applications, Warranties, Converters with SiC diodes. |
| Ref [7] | Investigation of subpanel level MPP tracking for increasing yield and reduce mismatching losses. | Efficiency, Power decoupling, MPP tracking. | Higher efficiency, loss model of multi input AC module converter. | Control effort, standby losses, hardware cost, sub string mismatch losses. |
| Ref [8] | Single phase grid connected PV micro inverter with reactive power support capability, constructed by bi-directional buck boost converter. | Grid voltage, peak current envelope, control strategy, efficiency. | High efficiency at unity power factor operation, reactive power supply using control strategy. | No consideration of cost and losses. Installation positions. |
| Ref [9] | Grid- tied single phase PV Micro inverter utilizing a split coil inductor. | Micro inverter Losses, control actions and measurements. | Reduced devices with increased number of levels, sole DC source without balance capacitor voltage, reduced semiconductor losses. Highly efficient micro inverter. | Losses ignored, high cost is a major factor. |
| Ref [10] | Impedance source PV micro inverter based on system level electro thermal modeling | Power loss on junction temperature, enclosure temperature, thermal cross coupling effect between components. | Thermal cross coupling effect , prediction of system wear out failure , long term reliability | Identification of weakest link in PV micro inverter, benchmark various design techniques for reliability improvement. Empirical devices may lead to errors due to different operating conditions, Installation positions. |
| Ref [11] | Two stage micro inverter design of a grid connected PV. | Power conversion efficiency, reliability, Power decoupling. | Long term stress analysis, life time prediction and reliability modeling. | Unreliability distributions for different HEMTs, degradation of PV module will slow down the wear out of micro inverters, failure modules are not considered. |
| Ref [12] | Physics of failure (PoF) based approach to correlate damp heat test for micro inverter reliability assessment. | Efficiency , output current and voltage ,total harmonic distortion | Damp heat , reliability, time to failure | Electrical Losses, No consideration of cost and losses. |

| | | | | |
|----------|---|--|---|---|
| Ref [13] | Improvement of reliability of DC link from reliability oriented and conditioning monitoring of DC link modes. | Reliability, failure mechanism , failure modes , life time models | Reliability oriented design approaches and condition monitoring methods are thoroughly presented | Coupling effect among various stressors on the life time of capacitors, noninvasive condition monitoring methods with less realization effort and higher estimation accuracy. |
| Ref [14] | MPPT controlled hybrid concept for PV Inverters. | Constant power generation, maximum power point tracking, efficiency, thermal loading, reliability. | Efficiency of annual energy yield in MPPT mode, inverter efficiency of power devices. | Selection of power limit, verification of feasibility, effectiveness of proposed control concept. |
| Ref [15] | Comparison of selected micro inverter in term of components counts, power rating and CAC efficiency | Power rating , MPPT range, power factor , Power density | The merits and drawbacks of main stream product in micro inverter were demonstrated. | Contributing roles of advanced power decoupling circuits and power semiconductor components are not considered. |
| Ref [16] | Reliability assessments of single phase PV micro inverter considering mission profile and uncertainty. | Life time model, manufacturing process, ambient temperature, solar irritation | Micro inverter installed in one part of the country has a longer life time than the one installed in some other area. Film capacitors have acceptable life time in the active power decoupling methods. | Reliability oriented investigation, limitation on disregarding temperature cycling and loading condition. |

In Table 2, critical review of previous researches in the field of micro inverter is discussed in which the methodology, parameters, achievements and deficiencies are considered in detail.

3. MOTIVATION

MOSFETs and capacitors are considered the critical components of micro inverters. The lifetime of the electrolytic capacitor is very much reliant on the operation environment. The increase in the equivalent series resistance (ESR) may evaporate the aqueous component electrolytes at high operating temperature due to which much heat is produced inside the capacitors and as a result, it reduces the capacitance and increases the evaporation rate.

The high ripple current produces greater joule heating and pushes the micro inverters to the condition of capacitor dry out failure. Even more, ripple current is higher at solar noon time when the solar irradiance is at its peak and this is when the micro inverter temperature is also highest. Therefore, a time series study of noon time data can provide important thermal information that can help one to understand the degradation mechanism of the micro inverter better.

During the power cycle, the rapid heat is formed on the die package due to this heat in the die attachment thermal stresses may occur which leads to other failure like wire breakage and bond

breakage. The likelihood of avalanche failure is higher at solar noon time due to high power-voltage current conditions. One of the main factors affecting the efficiency and PV system performance are the losses in the electrical system. Due to which the life span of the PV system is dramatically reduced. To overcome this, research on the multiple parts and components of the PV system are carried out by the scientific community. Mostly the focused areas are increasing the efficiency, reliability and optimization of the system.

Micro inverters have many advantages as compared to traditional string inverter. One of the main drawbacks of micro inverter is that they have a shorter life span as compared to the life span of solar modules. The average life span of certified PV modules is 20 years. Some manufactures even awarded guarantee for 25 years. In PV systems, each PV module has its own installed micro inverter whose life span varies between 5 to 10 years after which it has to be replaced and leads to increase cost of the PV system.

Our major contributions in designing low losses micro inverters will be reduced cost, enhanced safety, able to be tracked in real time, testing will be much reliable in extreme weather conditions. These features will lead to overall better ratings and investments in micro inverters over time.

4. MODEL TO CALCULATE LOSSES IN MICRO INVERTERS

Some of the factors which affect the life span of micro-inverters are:

- Electrical losses in DC Link electrolytic capacitor
- Thermal stresses in DC Link electrolytic capacitor
- Electrical losses in MOSFET
- Thermal stresses in MOSFET
- Electrical losses in diode
- Thermal stresses in diode

4.1 Losses in Capacitor

The electrical losses in micro inverters can be found by the following formula:

$$P_{\text{loss(cd)}} = \sum_{j=1}^{j=\infty} i_{c1}(f_j)^2 \text{ ESR}(f_j) \quad (1)$$

where $P_{\text{loss(cd)}}$ is the loss occurred in conduction switch, i_{c1} is the current following through the capacitor and ESR is the equivalent series resistance of the capacitor. The main reason of the electrical losses in the capacitor is because of equivalent series resistance of the capacitor and the current harmonics; with reducing the ESR of the capacitor the electrical losses can be reduced and vice versa. The electrical losses increase the temperature of the capacitor which in turn reduces the life span of the micro inverter.

Thus, there is a direct relation in the electrical and thermal stress; the temperature of the capacitor can be achieved by the following formula:

$$T_h = T_{\text{ambi}(t)} + Z_{\text{th}} P_{\text{loss(cd)}} \quad (2)$$

where $T_{\text{ambi}(t)}$ is the ambient temperature and Z_{th} is the thermal impedance.

4.2 Losses in Diodes

The main losses occur in diodes are conduction losses, switching losses and thermal losses. Diode has some body resistance; so, when it is turned ON or turned OFF, there may be a voltage and current drop across it which give rise to the conduction losses that can be denoted by the following formula:

$$P_{\text{loss(cond)}} = V_{D_j(\text{on})} i_{D_j(\text{on})} \quad (3)$$

where $P_{\text{loss(cd)}}$ is the loss occurred in conduction V_{D_j} and i_{D_j} is the ON state current in diode.

Due to the switching nature of the micro inverter, the diode has to quickly turn ON and OFF. During ON state, the current should be maximum and the voltage is minimum while vice versa in the OFF state; but this does not happen instantaneously and takes some time and thus, gives rise to the switching losses:

$$P_{\text{loss(sw)D}_j} = \frac{f_{\text{sw}}(Q_{\text{rrj}}V_{D_j(\text{off})})}{4} \quad (4)$$

where Q_{rr} is the reverse recovery charge.

So, the total electrical losses (conduction + switching) in diode can be found by the following formula:

$$P_{\text{loss(D}_j)} = V_{D_j(\text{on})} i_{D_j(\text{on})} + \frac{f_{\text{sw}}(Q_{\text{rrj}}V_{D_j(\text{off})})}{4} \quad (5)$$

As the electrical losses give rise to the temperature in diode, it also directly produces thermal stresses in the diode which can be calculated using the following formula:

$$T_{j(t)} = T_{\text{amb}(t)} + P_{\text{loss(mos or diode)}}(Z_{\text{th}(j-h)} + Z_{\text{th}(h-a)}) \quad (6)$$

where $T_{\text{amb}(t)}$ is the ambient temperature and $P_{\text{loss(mos or diode)}}$ are the losses in MOSFET and diode.

4.3 Losses in MOSFETS

Diode and MOSFETS are both semiconductor devices but with different structure configuration. Therefore, the losses present in diodes are also found in MOSFETS but are different due to the material parameters of the devices.

The conduction losses in the MOSFETS can be found by:

$$P_{\text{loss(mos j)}} = R_{\text{mos(j)}} i_{\text{mosj}}^2 \quad (7)$$

where $R_{\text{mos(j)}}$ is the body resistance of the MOSFET and i_{mosj}^2 is the current flowing through it.

The switching losses in the MOSFETS can be found by:

$$P_{\text{loss(switcing)}} = f_{\text{sw}}(V_{\text{mossj(on)}} i_{\text{mossj(on)}} t_{\text{rt}} + V_{\text{mossj(off)}} i_{\text{mossj(off)}} t_{\text{ft}})^2 \quad (8)$$

and the thermal losses in the MOSFETS can be found by the same equation (6).

5. METHODOLOGY

The main focus of this research article is to investigate the thermal and electrical stresses for the grid connected micro inverter performance improvement. The thermal stresses are totally

dependent on the electrical stresses, so the basic focus is to decrease the electrical stress which will eventually decrease the switching and conduction losses.

A single-phase grid connected H5 Micro inverter is identified in this model and the MOSFETS and diodes are under highly stressed. There are two methods to decrease the stresses in the micro inverter:

- Distribution of electrical and thermal stresses among components
- By decreasing the quantity of stresses

5.1 Quantity of Stress Reduction

In this method, the electric stresses in the semi-conductor devices of the micro inverter can be reduced by reducing their conduction losses and switching losses. By reducing these losses, the rise in temperature of the device can be controlled, which in turn, will limit the thermal stresses on the components. These can be achieved by introducing technological changes in the diodes and MOSFETs, either:

- (1) By decreasing the on-state resistance of the components and leakage current capability. This leads to decrease in conduction losses. To achieve this, we have to focus on manufacturing level which is costly.
- (2) By decreasing their reverse recovery time for diodes and decreasing rise and fall time for MOSFETs to decrease the switching losses in both components, which is also manufacturer-oriented approach and costly.

5.2 Stress Reduction Among Components

In this technique, the losses of the micro inverters are reduced by distributing the stresses. Stresses can be reduced by adding extra components of same power rating with existing components. By using two components of same rating together, stresses are distributed on two components instead of one. Less stresses caused less losses in the components. The targeted components are the semi-conductor components which include diode and MOSFET.

Table 3 Difference between electrical and thermal stress reduction and distribution

| Stress Distribution | Stress Reduction |
|--|--|
| In this technique, the aim is to distribute the electrical and thermal stress among the components | In this technique the aim is to eliminate the electrical and thermal stress. |
| The result is consistency improvements | The result is reliability improvements |
| Basic circuit changes needed for stress distribution | Technological changes needed for stress elimination |
| Applied on diodes, MOSFET, IGBT etc. | Applied on diodes , MOSFET etc. |

In Table 3, the basic difference in electrical and thermal stresses technique is discussed, in which the stress distribution technique is adopted for the micro inverters. The components targeted in the micro inverter are the semiconductors of diode and MOSFET. New topology is introduced in the work in which the well-established H5 micro inverter is selected. The basic model is first analyzed in detail for the stress losses, conduction losses and switch losses.

After analyzing the H5 micro inverter, changes are applied to the circuit of the micro inverter. New components are added to it. New semiconductor switches of the same power rating and type are added in parallel to the existing components so that the stresses can be distributed among two components instead of one. A new topology is introduced, where the new model is finalized

in detail for the stress losses, conduction losses and switch losses. Both the results of H5 and proposed topology are compared and analyzed. The flow chart of the proposed model for 300W micro inverter is shown in Figure 3.

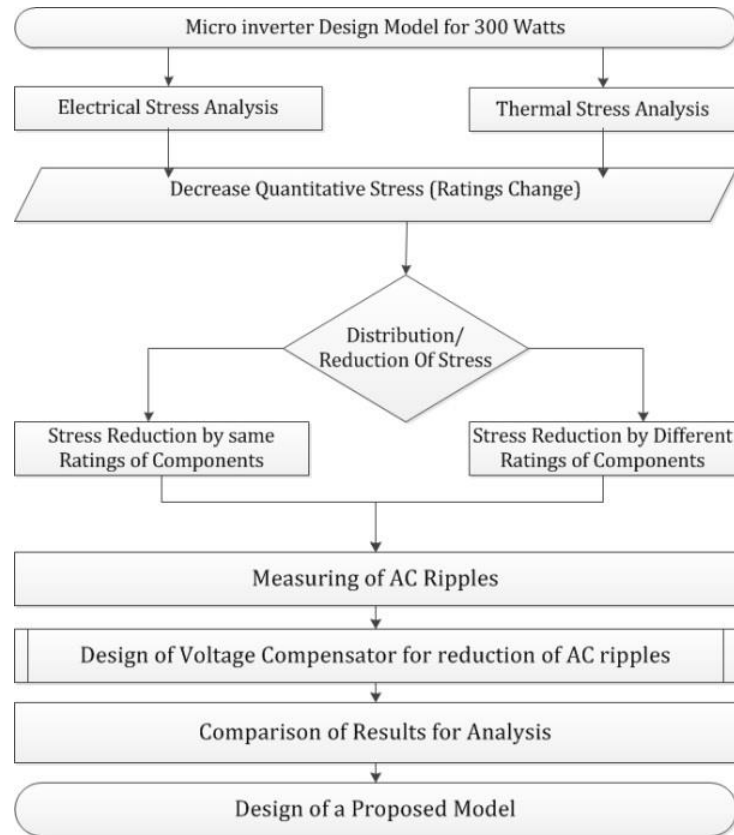

Figure 3. Flow chart of the proposed study

6. SYSTEM DESCRIPTION

The basic circuit of H5 micro inverter is shown in Figure 4. This circuit has no electrical and thermal stress distribution components, hence all the thermal and electrical stresses fall on the circuit diodes and MOSFETs which reduce the performance and reliability of the inverter. The major drawback is that it reduces the life span of the micro inverter.

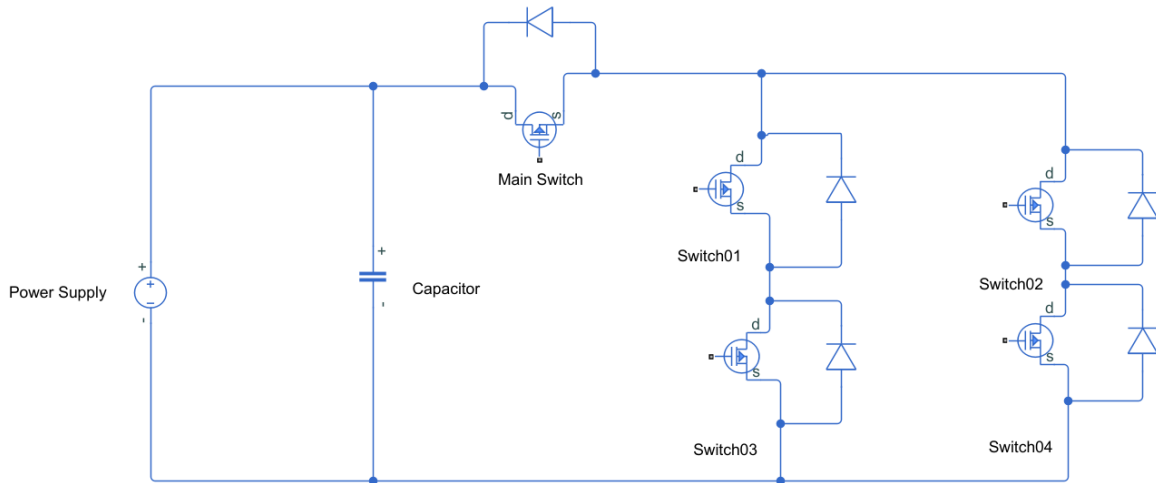

Figure 4. Single Phase H5 Micro inverter without Electrical stress distribution

In Figure 4, the “S” represents the semiconductor switches used in the H5 micro inverter while “C” represents the capacitor and “V” is the voltage source. In Figure 5, we have proposed H5 micro inverter topology in which we have distributed the thermal and electrical stresses in two ways:

- Distribution of stresses in diodes
- Distribution of stresses in MOSFETS

In this model, “A” represents the auxiliary switches used in the micro inverter topology to distribute stress in switches.

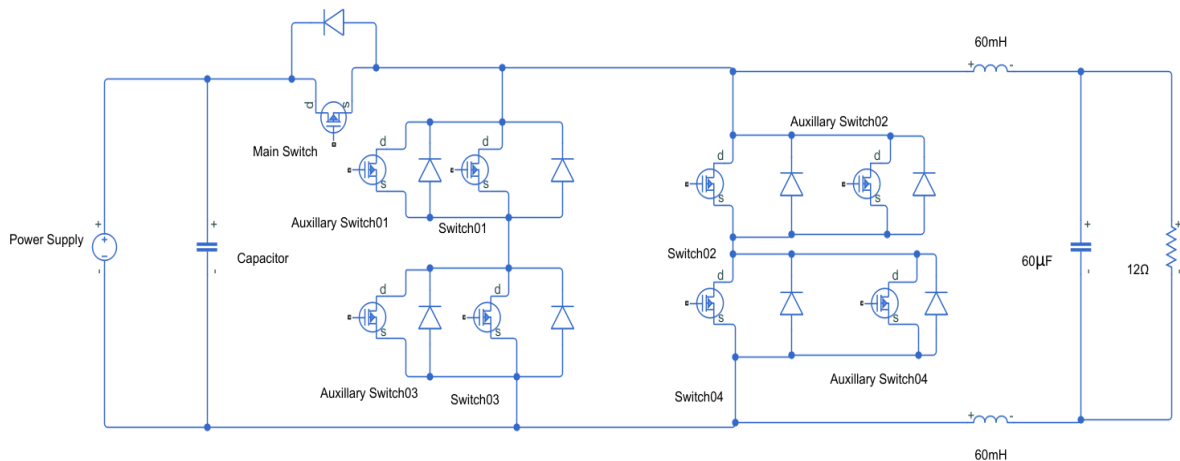

Figure 5. Single Phase H5 Micro inverter with Electrical stress distribution

In Figure 5, we have selected MOSFETS with recovery diodes so that in reverse state, diodes can provide alternate path. For the MOSFET and diode stress distribution in the semiconductor switches, we have added one additional diode-based MOSFETS in parallel to each existing diode-based MOSFET. Both the diodes are placed as forward biased keeping in view that both diodes are of same rating which gives the advantage that both diodes will carry the current, thus reducing the electrical stress on a single diode. Due to fast switching in the negative interval, the diode becomes reverse biased which causes leakage current. This can cause damage to the diode. To overcome this issue and protect the diode, the introduction of anti-parallel diode with the main diode in H5 micro inverter is a useful technique. Whenever the main diode is reversed biased, the

anti-parallel diode will become forward biased, therefore the leakage current is significantly reduced, thus decreasing the overheating in the main diode.

Similarly, to reduce the electrical and thermal stress in MOSFETS, the same procedure of diode stress distribution is adapted. With each existing MOSFETS, an additional MOSFET of same power rating is added so that both can operate at the same time, thus distributing the electrical stresses. The high voltage transients because of the high switching frequency of the MOSFETS can damage the semiconductor components and alter the behavior of the inverter. To reduce the voltage transients, a capacitor is added at the output terminal to tackle the sudden change in the voltage. Although these techniques increase the overall cost because of the additional components, they increase the performance and enhance the reliability of the micro inverter. The system is designed using PSIM electronics circuit simulation software and plots are generated using its circuit design parameters.

7. SIMULATION & CIRCUIT PARAMETERS

7.1 Voltage Source

Voltage source is a supply that is independent of the current flowing in the circuit and it is defined as the input voltage which is applied to the circuit for its functionality. In our case, we have set our source voltage as 100V.

7.2 Switching Frequency

The rate by which micro inverter switching device is turned ON/OFF is called switching frequency and ranges from few kHz to some MHz. The switching frequency in this system is set as 20 KHz.

7.3 Duty Cycle

A power cycle which is also known as duty cycle is a time to complete ON /OFF cycle and set as 50%. The method that corrects the output wave form is called output frequency and is set as 50Hz.

7.4 Internal Resistance/ESR

The internal resistance/equivalent series resistance represents the loss of useful energy in micro inverter which consists of ideal capacitor and resistor. It is actually the energy dissipated and is set as 0.2 ohm.

7.5 Forward Voltage of Diode

Forward voltage is a voltage drop across the diode when it is conducting in the forward direction and is set as 0.5V.

7.6 DC Link Capacitance

A DC link capacitance is used in micro inverter to minimize the voltage variations effects when the load changes and is set as 60uF and the power rating are set as 300W.

The Monte Carlo model is used in simulation to find the probability of different outcomes in the presence of random variables.

8. RESULTS AND DISCUSSION

The following simulation results show the comparison of basic H5 Micro inverter and the stress distributed micro inverters. As there are 4 main semi-conductor components used in the H5 inverter, 4 additional auxiliary components are added, one with each component. Each switch and its auxiliary switch are analyzed individually (graphs) and the total effect is then shown in Table 4.

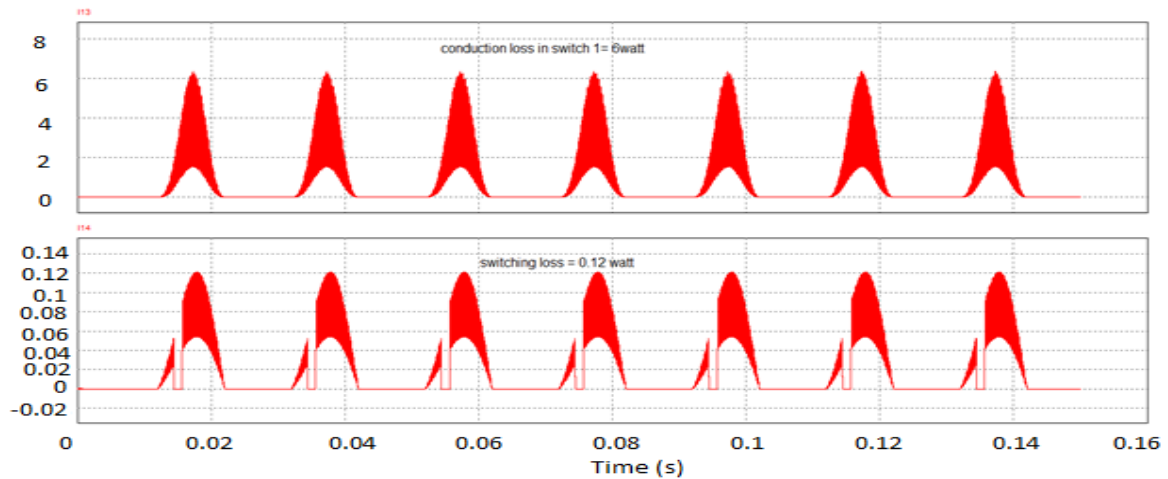

(a)

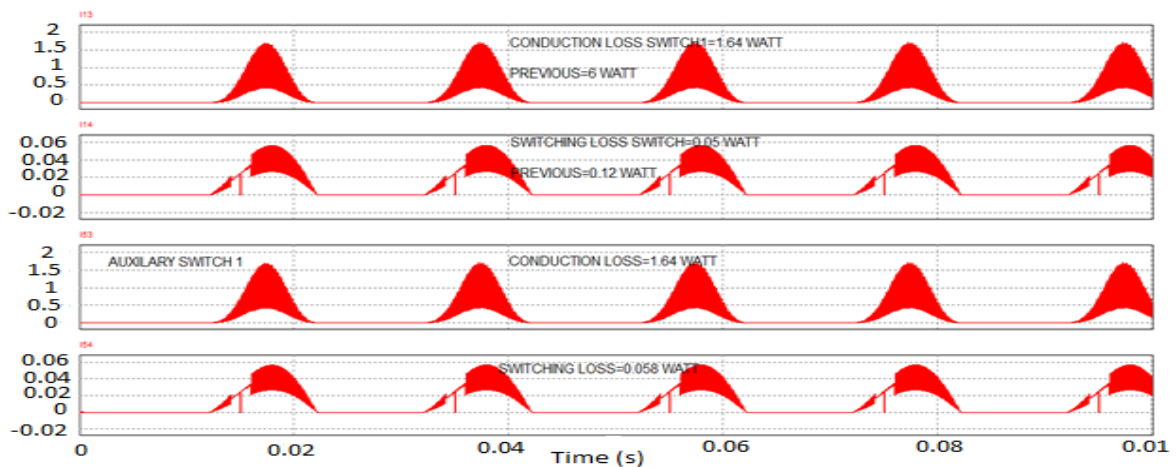

(b)

Figure 5. Losses in switch 1 of: (a) basic H5 inverter, (b) modified micro inverter

Figure 5 shows the switching and conduction losses in both micro inverter topologies for the first switch (s1) used in them. From the graphs, it can be seen that the H5 inverter has higher peaks as compared to the modified inverter. The conduction loss in the s1 switch of H5 inverter is 6.2 watt, while for the modified inverter, the s1 conduction loss is 1.64 watt and in the auxiliary switch is 1.64 watt, which shows that the stresses have been distributed. The total conduction loss in that segment is 3.28 watt which is almost half of H5 inverter. Similarly, the switching loss of H5 inverter is 0.12 watt. For the modified inverter, the switching loss in the s1 switch is 0.05 watt while in the auxiliary switch is 0.058 watt. The total switches loss in the inverter is 0.108 watt

which is less than the H5 inverter. From the results of both losses in s1 switch, it can be seen that by stress reduction method, not only the stresses and losses are distributed but also reduced.

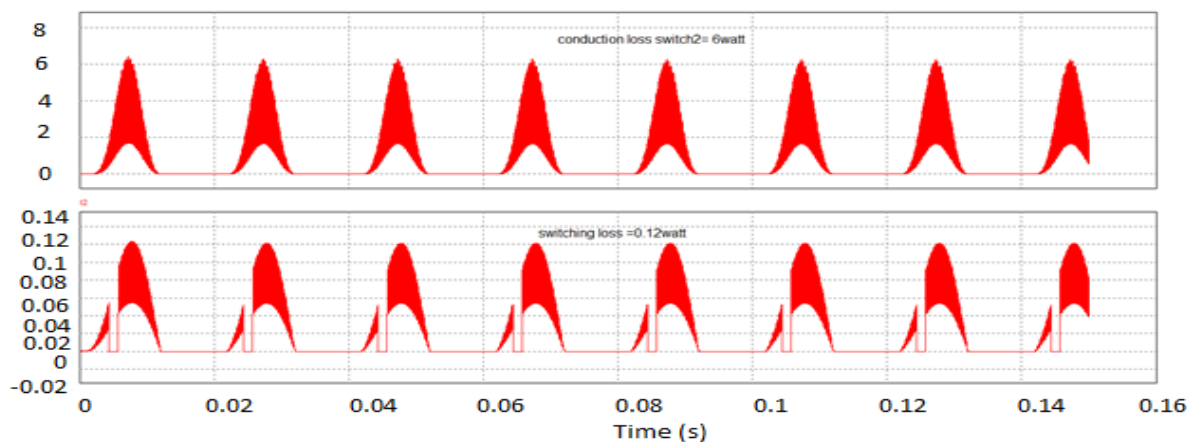

(a)

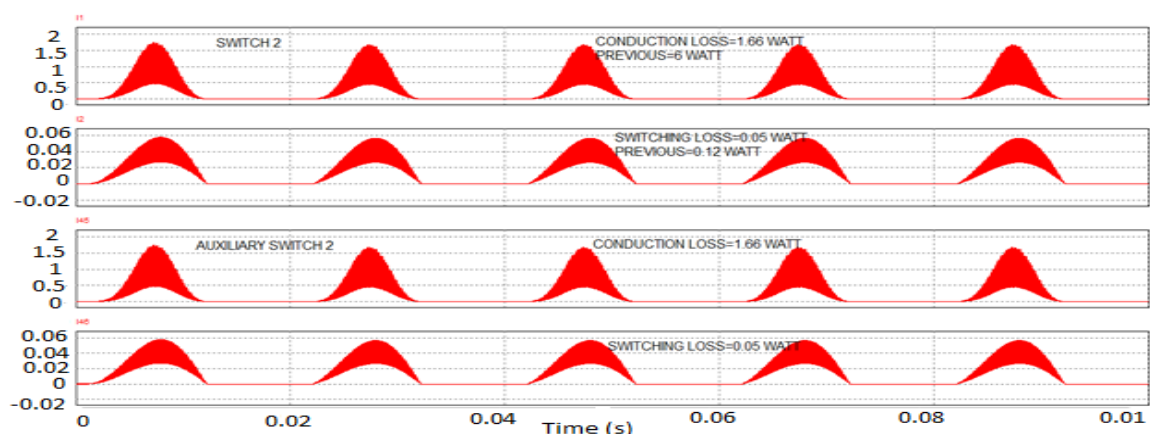

(b)

Figure 6. Losses in switch 2 of: (a) basic H5 inverter, (b) modified micro inverter

Figure 6 shows the switching and conduction losses in both micro inverter topologies for the second switch (s2) used in them. From the graphs, it can be seen that the H5 inverter has higher peaks as compared to the modified inverter. The conduction loss in the s2 switch of H5 inverter is 6.2 watt. While for the modified inverter, the s2 conduction loss is 1.66 watt and in the auxiliary switch is 1.66 watt, which shows that the stresses have been distributed. The total conduction loss in that segment is 3.32 watt which is almost half of H5 inverter. Similarly, the switching loss of H5 inverter is 0.12 watt. For the modified inverter, the switching loss in the s2 switch is 0.05 watt while in the auxiliary switch is 0.05 watt. The total switches loss in the inverter is 0.1 watt which is less than the H5 inverter. From the results of both losses in s2 switch, it can be seen that by stress reduction method not only the stresses and losses are distributed but also reduced.

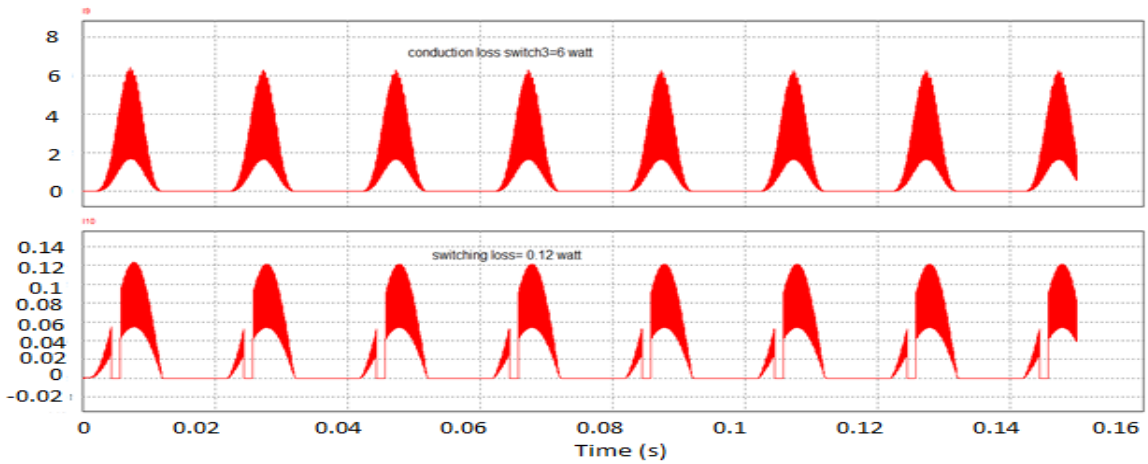

(a)

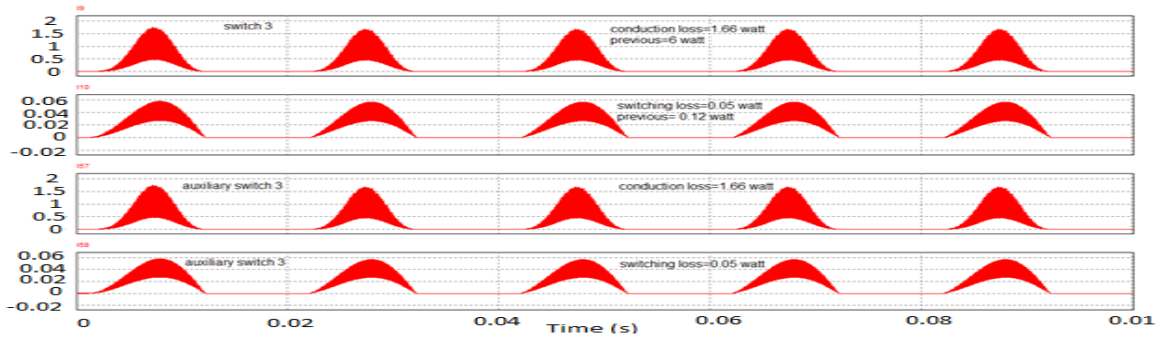

(b)

Figure 7. Losses in switch 3 of: (a) basic H5 inverter, (b) modified micro inverter

Figure 7 shows the switching and conduction losses in both micro inverter topologies for the third switch (s3) used in them. From the graphs, it can be seen that the H5 inverter has higher peaks as compared to the modified inverter. The conduction losses in the s3 switch of H5 inverter is 6 watt. While for the modified inverter, the s3 conduction loss is 1.66 watt and in the auxiliary switch is 1.66 watt, which shows that the stresses have been distributed. The total conduction loss in that segment is 3.32 watt which is almost half of H5 inverter. Similarly, the switching loss of H5 inverter is 0.12 watt. For the modified inverter, the switching loss in the s3 switch is 0.05 watt while in the auxiliary switch is 0.05 watt. The total switches loss in the inverter is 0.1 watt which is less than the H5 inverter. From the results of both losses in s3 switch it can be seen that by stress reduction method not only the stresses and losses are distributed but also reduced.

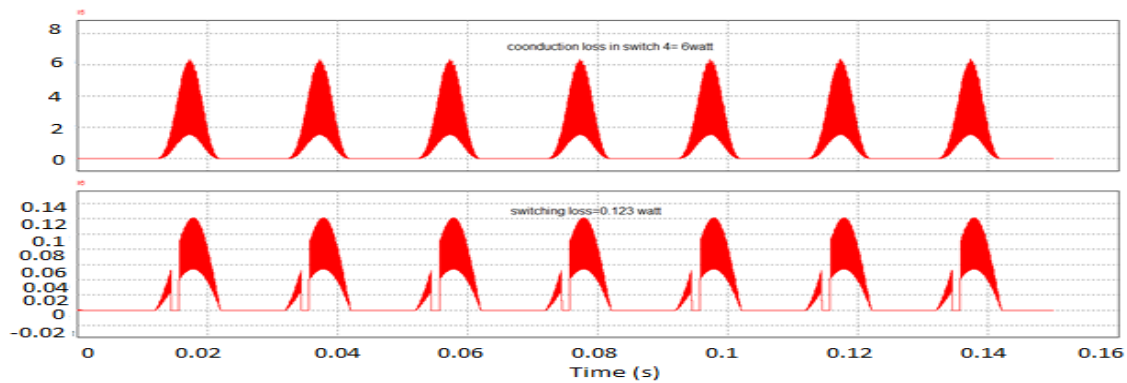

(a)

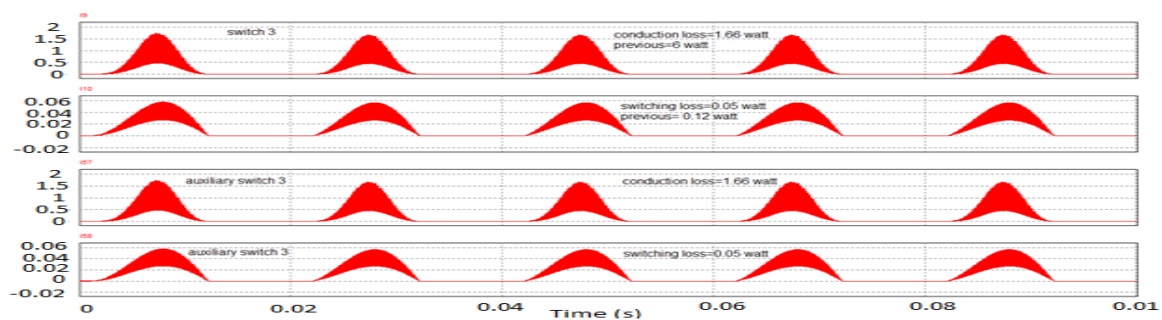

(b)

Figure 8. Losses in switch 4 of (a) basic H5 inverter (b) modified micro inverter

Figure 8 shows the switching and conduction losses in both micro inverter topologies for the fourth switch (s4) used in them. From the graphs, it can be seen that the H5 inverter has higher peaks as compared to the modified inverter. The conduction loss in the s4 switch of H5 inverter is 6 watt. While for the modified inverter, the s4 conduction loss is 1.64 watt and in the auxiliary switch is 1.66 watt, which shows that the stresses have been distributed. The total conduction loss in that segment is 3.3 watt which is almost half of H5 inverter. Similarly, the switching loss of H5 inverter is 0.123 watt. For the modified inverter, the switching loss in the s4 switch are 0.05 watt while in the auxiliary switch is 0.05 watt. The total switches loss in the inverter are 0.1 watt which is less than the H5 inverter. From the results of both losses in s4 switch, it can be seen that by stress reduction method not only the stresses and losses are distributed but also reduced.

Table 4 Comparison between basic and distributed losses in micro inverter

| Parameters | Conduction losses Basic-H5 | Conduction Losses Distributed-H5 | Switching Losses Basic-H5 | Switching Losses Distributed-H5 |
|--------------------|----------------------------|----------------------------------|---------------------------|---------------------------------|
| Switch 1 | 6.2 watt | 1.64 watt | 0.12 watt | 0.05 watt |
| Auxiliary switch 1 | NA | 1.64 watt | NA | 0.058 watt |
| Total S1 | | 3.28 watt | | 0.108 watt |
| Switch 2 | 6.2 watt | 1.66 watt | 0.12 watt | 0.05 watt |
| Auxiliary switch 2 | NA | 1.66 watt | NA | 0.05 watt |
| Total S2 | | 3.32 watt | | 0.1 watt |
| Switch 3 | 6 watt | 1.66 watt | 0.12 watt | 0.05 watt |
| Auxiliary switch 3 | NA | 1.66 watt | NA | 0.05 watt |
| Total S3 | | 3.32 watt | | 0.1 watt |
| Switch 4 | 6 watt | 1.64 watt | 0.123 watt | 0.05 watt |
| Auxiliary switch 4 | NA | 1.66 watt | NA | 0.05 watt |
| Total S4 | | 3.3 watt | | 0.1 watt |
| Total Inverter | 24.4 watt | 13.22 watt | 0.483 watt | 0.408 watt |

From the above results in Table 4, it can be seen that the basic H5 topology losses are high with the conduction losses being in the range of 6 watt and the switching losses being in the range of 0.12 watt, but in the stress distribution method with the addition of extra components, the loss on the individual components has reduced to 1.6 watt. The combined loss on single portion of the

inverter is 3.36 watt (base switch + auxiliary switch) which is significantly less than the basic H5 topology. The total losses of both the converters when compared show that the modified inverter has lesser losses than the H5 inverter. The total conduction loss of H5 inverter was 24.4 watt while for the modified inverter was 13.22 watt. The conduction losses are almost reduced to half. This reduction of losses will not only increase the efficiency of the inverter but also its life time. This concludes that by adding extra components of the same ratings with base components will reduces the stress on the micro inverter.

Table 5 Efficiency calculation for conduction losses

| S.No | Switches | Input Power Applied | In case of Basic Circuit | In case of Modified Circuit | Efficiency of Basic Circuit | Efficiency of Modified Circuit | Improvement |
|------|----------|---------------------|--------------------------|-----------------------------|-----------------------------|--------------------------------|---|
| 1. | S1 | 300 W | 6.2 | 1.64 | 2.06 % | 0.54 % | $\{(2.06-0.54)/2.06\} \times 100 = 73.78\%$ |
| 2. | S2 | 300 W | 6.2 | 1.66 | 2.06 % | 0.55 % | $\{(2.06-0.55)/2.06\} \times 100 = 73.30\%$ |
| 3. | S3 | 300 W | 6 | 1.66 | 2.0 % | 0.55 % | $\{(2.0-0.55)/2.0\} \times 100 = 72.5\%$ |
| 4. | S4 | 300 W | 6 | 1.63 | 2.0 % | 0.54 | $\{(2.0-0.54)/2.0\} \times 100 = 73\%$ |

Table 6 Efficiency calculation for switching losses

| S.No | Switches | Input Power Applied | In case of Basic Circuit | In case of Modified Circuit | Efficiency of Basic Circuit | Efficiency of Modified Circuit | Improvement |
|------|----------|---------------------|--------------------------|-----------------------------|-----------------------------|--------------------------------|---|
| 1. | S1 | 300 W | 0.12 | 0.05 | 0.04 % | 0.016 % | $\{(0.04-0.016)/0.04\} \times 100 = 60\%$ |
| 2. | S2 | 300 W | 0.12 | 0.05 | 0.04 % | 0.016 % | $\{(0.04-0.016)/0.04\} \times 100 = 60\%$ |
| 3. | S3 | 300 W | 0.12 | 0.05 | 0.04% | 0.016 % | $\{(0.04-0.016)/0.04\} \times 100 = 60\%$ |
| 4. | S4 | 300 W | 0.123 | 0.058 | 0.041% | 0.019% | $\{(0.041-0.019)/0.041\} \times 100 = 53.6\%$ |

Tables 5 and 6 indicate that the overall efficiency of the H5 modified inverter in case of conduction losses has been improved with the addition of stress distribution components. Four switches for stress distribution have been used and conduction as well as switching losses has been observed. Table 5 indicates the improvement in efficiency for conduction losses in four switches placed. The improvement in the case of switch s1 is 73.78%, s2 73.30%, s3 72.5% and s4 73%. The overall average efficiency achieved for conduction losses is 73.145%. Similarly, various efficiencies for switching losses is calculated in Table 6 which shows that efficiency improvement in s1, s2, s3 is 60% and for s4 is 53.6%. The overall average efficiency achieved for switching losses is 58.4%.

9. CONCLUSION

From the above study, it is concluded that the basic H5 topology in which single components were used, produces more electrical and thermal stress because lesser number of components have to handle the maximum power, which in turn, reduces the life span of micro inverter and thus, reduces the reliability of micro inverter. It was seen that for H5 inverter single switch, it has conduction loss in the range of 6 watt while the switching loss about 0.12 watt. The total conduction loss of the whole inverter was 24.2 watt while the switching losses was 0.483 watt. By adding extra components of proper rating and optimal placement, although the cost of the device increases, it significantly reduces the stresses on the micro inverter. It was seen that for the modified inverter single switch, it has conduction loss in the range of 1.64 watt while the auxiliary conduction loss also between 1.64 watt. The total conduction loss for individual switching segment is about 13.22 watt which is almost half of H5 loss. The switching loss of individual switches is 0.05 watt and auxiliary also about 0.05 watt. The total switching loss is about 0.1 watt for each segment which was less than H5 inverter. The total conduction loss of H5 inverter is 24.4 watts while for the modified inverter is 13.22 watt. The conduction losses are reduced to 73% and that of switching losses are reduced to 58.4%. This reduction of losses will not only increase the efficiency of the inverter but also its life time. This is because more components have to take control of the same high power so the stresses are distributed among more components and individual component has to face less stress and thus, increases the life span and reliability of the micro inverter.

ACKNOWLEDGEMENT

The authors are grateful to Iqra National University, Peshawar for its permission to work in their computer research lab and financial support. The authors would also like to thank Prof. Dr. Sheeraz Ahmed for his guidance and contribution towards this research work.

REFERENCES

- [1] Alluhaybi, K., Batarseh, I., & Hu, H. (2019). Comprehensive review and comparison of single-phase grid-tied photovoltaic microinverters. *IEEE Journal of Emerging and Selected Topics in Power Electronics*, 8(2), 1310-1329.
- [2] Dong, D., Agamy, M. S., Harfman-Todorovic, M., Liu, X., Garces, L., Zhou, R., & Cioffi, P. (2017). A PV residential microinverter with grid-support function: Design, implementation, and field testing. *IEEE Transactions on Industry Applications*, 54(1), 469-481.
- [3] Hacke, P., Lokanath, S., Williams, P., Vasan, A., Sochor, P., TamizhMani, G., ... & Kurtz, S. (2018). A status review of photovoltaic power conversion equipment reliability, safety, and quality assurance protocols. *Renewable and Sustainable Energy Reviews*, 82, 1097-1112.
- [4] Harb, S., & Balog, R. S. (2012). Reliability of candidate photovoltaic module-integrated-inverter (PV-MII) topologies—A usage model approach. *IEEE transactions on power electronics*, 28(6), 3019-3027.
- [5] Mapelli, F. L., Tarsitano, D., & Mauri, M. (2009). Plug-in hybrid electric vehicle: Modeling, prototype realization, and inverter losses reduction analysis. *IEEE Transactions on Industrial electronics*, 57(2), 598-607.
- [6] Kouro, S., Leon, J. I., Vinnikov, D., & Franquelo, L. G. (2015). Grid-connected photovoltaic systems: An overview of recent research and emerging PV converter technology. *IEEE Industrial Electronics Magazine*, 9(1), 47-61.

- [7] Leuenberger, D., & Biela, J. (2016). PV-module-integrated AC inverters (AC modules) with subpanel MPP tracking. *IEEE Transactions on Power Electronics*, 32(8), 6105-6118.
- [8] Min, G. H., Lee, K. H., Ha, J. I., & Kim, M. H. (2018, May). Design and control of single-phase grid-connected photovoltaic microinverter with reactive power support capability. In *2018 International Power Electronics Conference (IPEC-Niigata 2018-ECCE Asia)* (pp. 2500-2504). IEEE..
- [9] Nezamuddin, O., Crespo, J., & dos Santos, E. C. (2016, June). Design of a highly efficient microinverter. In *2016 IEEE 43rd Photovoltaic Specialists Conference (PVSC)* (pp. 3463-3468). IEEE.
- [10] Shen, Y., Chub, A., Wang, H., Vinnikov, D., Liivik, E., & Blaabjerg, F. (2018). Wear-out failure analysis of an impedance-source PV microinverter based on system-level electrothermal modeling. *IEEE Transactions on Industrial Electronics*, 66(5), 3914-3927.
- [11] Shen, Y., Wang, H., & Blaabjerg, F. (2017, June). Reliability oriented design of a grid-connected photovoltaic microinverter. In *2017 IEEE 3rd International Future Energy Electronics Conference and ECCE Asia (IFEEC 2017-ECCE Asia)* (pp. 81-86). IEEE.
- [12] Vasan, A., Laskai, L., & Ilic, M. (2017, March). Defining humidity test duration for microinverter reliability assessment: A physics-of-failure approach. In *2017 IEEE Applied Power Electronics Conference and Exposition (APEC)* (pp. 2336-2340). IEEE.
- [13] Wang, H., & Blaabjerg, F. (2014). Reliability of capacitors for DC-link applications in power electronic converters—An overview. *IEEE Transactions on Industry Applications*, 50(5), 3569-3578.
- [14] Yang, Y., Wang, H., Blaabjerg, F., & Kerekes, T. (2014). A hybrid power control concept for PV inverters with reduced thermal loading. *IEEE Transactions on Power Electronics*, 29(12), 6271-6275.
- [15] Yuan, J., Blaabjerg, F., Yang, Y., Sangwongwanich, A., & Shen, Y. (2019, April). An overview of photovoltaic micro inverters: Topology, efficiency, and reliability. In *2019 IEEE 13th International Conference on Compatibility, Power Electronics and Power Engineering (CPE-POWERENG)* (pp. 1-6). IEEE.
- [16] Zare, M. H., Mohamadian, M., Wang, H., & Blaabjerg, F. (2017, February). Reliability assessment of single-phase grid-connected PV microinverters considering mission profile and uncertainties. In *2017 8th Power Electronics, Drive Systems & Technologies Conference (PEDSTC)* (pp. 377-382). IEEE.
- [17] Shen, Y., Chub, A., Wang, H., Vinnikov, D., Liivik, E., & Blaabjerg, F. (2018). Wear-out failure analysis of an impedance-source PV micro inverter based on system-level electrothermal modeling. *IEEE Transactions on Industrial Electronics*, 66(5), 3914-3927.

