

Fabrication of a Hand-held Electronic Nose

Markom, M.A.¹, Md Shakaff, A.Y.¹, Adom, A.H.², Ahmad, M.N.³, Abdullah, A.H.²

School of Computer and Communication Engineering,¹
Northern Malaysia University College of Engineering
Email: azira_putra@yahoo.com

School of Mechatronic Engineering,²
Northern Malaysia University College of Engineering

School of Bioprocess Engineering,³
Northern Malaysia University College of Engineering

Abstract

An electronic nose is a device that performs the electronic olfactory to substitute human experts. The development of these devices is growing faster due to higher demand. However, current electronic noses usually are very complicated and expensive. This paper presents the work of the fabrication of a hand-held electronic nose for commercialisation. The fabrication of the electronic nose involved three stages: software, hardware and case development. The e-nose consists of a sensors array integrated with Hitachi microcontroller and neural network algorithm as pattern recognition. The completed e-nose showed that it was able to discriminate sample which infected by *ganoderma spp.*

Keyword:

Fabrication, Hand-held, Electronic nose, Microcontroller

1 Introduction

In recent years, the development of innovative instrumentations such as electronic nose has been investigated and implemented. The e-nose, often referred as an intelligent device, can mimic the human sense of olfaction and can be used for detection, recognition and classification of volatile compounds and odours [1]. This machine has been applied widely in food industry as well as for air quality monitoring [1].

The available electronic noses, however, do not address the current market needs. This is because the market demands a simple, portable and multi-functional product. In addition to that, the current electronic noses are also expensive. Most of the commercially available e-nose retails for RM 60k and above.

A hand-held electronic nose is one of the solutions to the market demand. The proposed e-nose is a truly portable product. It can be used in field for recognition and classification sample without using a personal computer to process input data. Also, this e-nose can be implemented as a multi-purpose instrument to classify fruits in terms of ripeness as well as to detect plants malaise. The proposed e-nose is developed to be cost efficient as it was made using off-the-shelf-components.

The fabrication of the e-nose was implemented in three stages. This translates into the stages development of the hardware, software as well as the case for the e-nose. **Figure 1** shows the system block diagram that involved in the development stages.

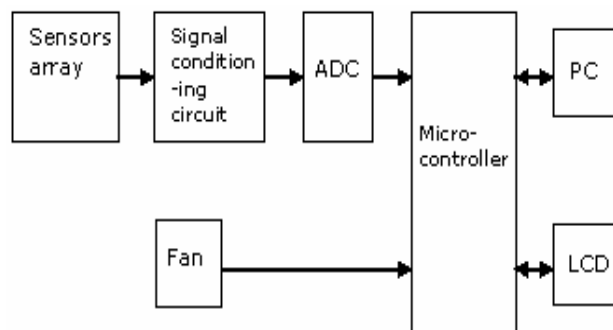

Figure 1: Block Diagram Hand-held Electronic Nose System

2 System Descriptions

2.1 The sensing element

The sensors of the e-nose comprises of eight metal oxide semiconductor (MOS) gas sensors. These

sensors were purchased from Figaro Engineering Inc. Japan. **Table 1** below describes the sensors used in this system.

Table 1: Sensors used in the Hand-held Electronic Nose

Sensor	Sensitive to
TGS 2106	Air quality sensor for CO/HC
TGS 2104	Air quality sensor for NOx
TGS 2600	Air contaminant
TGS 2602	Air contaminant
TGS 2620	Alcohol, organic vapour
TGS 822	Organic vapour
TGS 825	Hydrogen sulphide
TGS 826	Ammonia

In general, the sensor's conductivity increases in the presence of a detectable volatile compound [2]. This conductivity is depends on the volatile concentration in the air. A simple electrical circuit has been designed for every sensors used in this system. The purposed is to convert the change in conductivity to output signal.

2.2 The Microcontroller

A H8/3687 microcontroller unit from Hitachi was used to control the system. It was programmed using C language in Hitachi Workshop Version 2 software. Hitachi microcontroller was chosen because of the special features as stated below [3]:

1. Central processing unit with internal 16 bits architecture.
2. Built in ADC 10 bits.
3. Built in EEPROM and can add more memory.

These features are favourable for the project because of the large memory requirements to save the data and programmed. Also, the microcontroller is required to conduct to real time processing.

2.3 Neural Network

Neural network is used for pattern recognition. In this system, the *Multi-Layer Perceptron* (MLP) which is trained using the *Backpropagation* (BP) algorithm was applied. Typically, The MLP comprises of an input, output and one or more hidden layers. There are two phases in the neural information process; *a training phase* and *a testing phase*. At the beginning of the training phase, all the weights are arbitrarily chosen. Through iteration of the network, the weights are refined until they generate the desired output. This process determines a neural model, which is

often called the 'learning phase' of the network. The testing phase of the network occurs when the network is tested with unseen samples to yield classification results by selecting the appropriate output unit.

3 Approach and Methods

3.1 Hardware Development

The hardware development consists of the sensors, signal conditioning and controller system circuit design.

The main component in designing the sensors circuit is load resistors (R_L) (refer figure 2) [2]. The signal output is obtained through these R_L s which also act as protector by regulating the sensors power consumptions (P_s). These R_L s then have been integrated with signal conditioning circuit.

A tunnel or sensor housing was developed to the flow of the gas sample over the sensors. At one end of the tunnel, a fan sucks in gas sample from the opening end. As the gas sample flows, it will hit the surface of the sensors along the tunnel. Then, the sensors will respond immediately and give an output signal. The tunnel was designed using 3-D design software and fabricated using 3D printer.

The signal conditioning was developed for every sensor in this system. It consists of filter and amplifier for all output sensors. The filters were designed using low pass filters while the amplifiers were designed using inverting amplifiers. These circuits are used to manipulate the output signal from sensors to ADC before the signal goes to microcontroller.

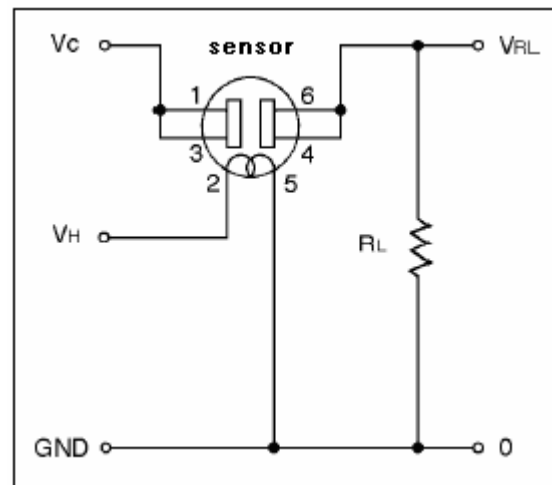

Figure 2: The Sensor Circuit for TGS 825

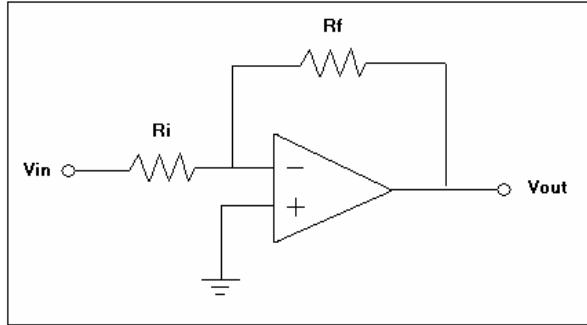

Figure 3: Inverting Amplifier

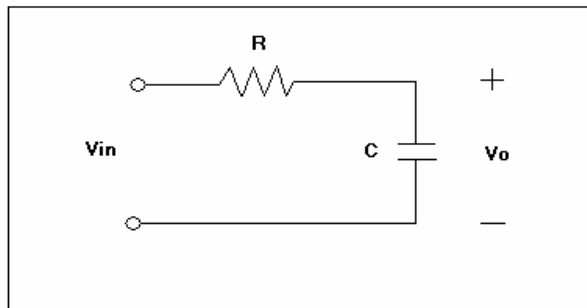

Figure 4: Low Pass Filter

3.2 Software Development

Software development included the microcontroller programmed. Listed below are the functions for the microcontroller.

1. To obtain data from ADC.
2. To process input data to do the classification for sample.
3. To interact with personal computer.
4. To perform data to be displayed.

The main program of the microcontroller allows the user to choose which process they wish by pressing buttons 1 to 4. The first button will conduct user back to the main menu. The second is the data collection process while the third is the data recognition process. The last one initiates the PC interaction process with the e-nose.

The data collection process will automatically save the sample readings in EEPROM. The fan will be on during the process to ensure the gas sample flows through the tunnel. Also, the data in EEPROM can be viewed using the liquid crystal display (LCD). In this part, scaled factor for data recognition can be calculated.

The second sub-program is data recognition. This program performs the sample classification process and the fan will also on as well as the data collection process. Before the process starts, sample data are

trained in the PC until the neural network model are obtained. The weight of the NN then uploaded onto the EEPROM by choosing the fourth button in the main menu. After uploaded the weight, the sample data can be collected and the result of the classification will be displayed at LCD.

The last sub-program is PC interaction. In this program, data from EEPROM can be downloaded to PC to do the neural network training in PC. Then, the neural network weight that obtained from the training can be uploaded into EEPROM for data recognition process.

3.3 Case Development

The design of a prototype hand-held e-nose is done using SolidWorks 3D design. Finally, the prototype casing was assembled with the other parts of the hand-held system. The tunnel or sensor housing was also developed using this method. The design of the case are then fabricated using the 3D printer. After the fabrication process, the case was printed.

4 Results and Discussion

The hand-held electronic nose can be used successfully to recognize sample in field. There does not need a personal computer to process data for classification. Figure 6 and 7 show the hand-held electronic nose after completed the fabrication.

The performance of the hand-held electronic nose is quite stable. The FIGARO sensors array that had been used in the system successes to give a profile or fingerprint to volatile sample after tested at a few aroma. The Hitachi microcontroller also can function according to the program.

The first application that used this e-nose is ganoderma *spp* analysis. Ganoderma *spp* is a fungus that can cause death of the oil palm trunk. This analysis required researchers to discriminate sample which is infected by this fungus. The result showed that the data obtain from the e-nose can be training by neural network and then can be classified. Figure 5 shows the fingerprint of the infected and healthy sample.

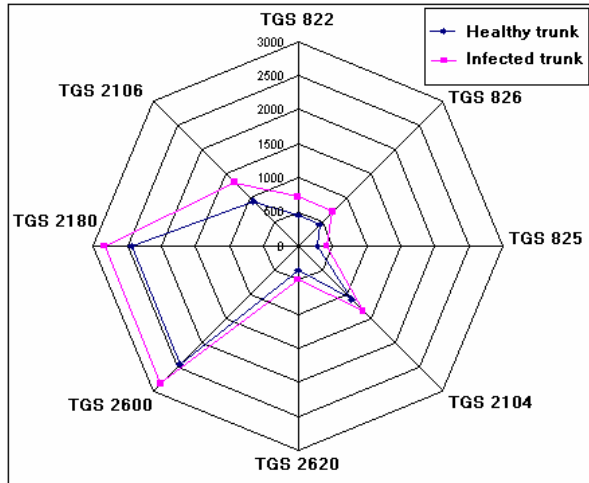

Figure 5: Healthy and Infected Trunks Fingerprint

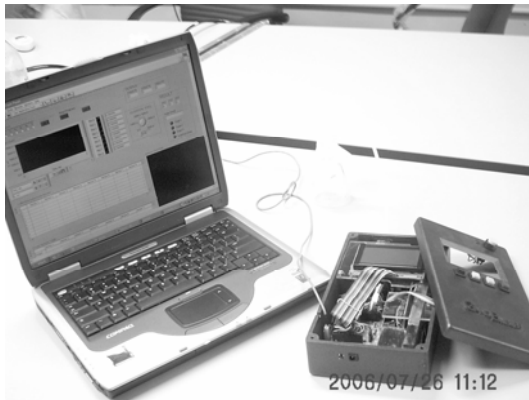

Figure 6: The Hand-held Electronic Nose Integrates With a Personal Computer

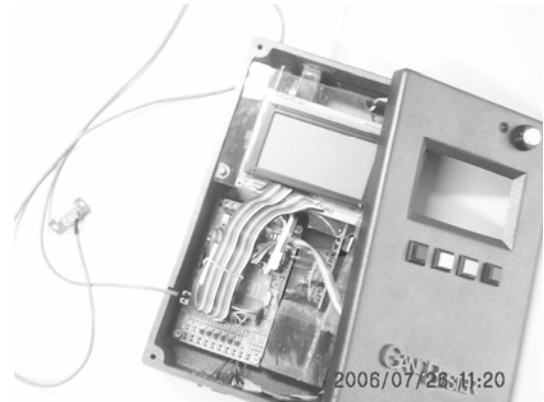

Figure 7: The Completed Hand-Held Electronic Nose System

5 Conclusions

The hand-held electronic nose can be used after verification process to ensure no failure either the software or hardware elements. This can be applied to detect, recognize and classify any volatile compounds or odours such as for fruit ripeness.

References

- [1] Paul, E. K., Lars J. K., Lars, H. L., Hashem, S., Kouzes, R. T., Electronic nose and their application.
- [2] Figaro Gas Sensor, (1992). Technical Reference, <http://www.figaro.com>, (July 2006)
- [3] Renesas Technology, (2005). <http://www.renesas.com>, (Jun 2006)
- [4] Md Salim S. N., Md Shakaff A. Y., Ahamd M. N., Adom A. H., Husin Z., (2005) Development of electronic nose for fruits ripeness determination, ICST 2005, 515-518
- [5] Iskandarani M.Z., Shilbayeh N. F., (2005), design and analysis of a smart multi purpose electronic nose system, Journal of computer science 1 (1): 63-71