

Investigation of Pressure Drop in Hydro-Pneumatic Driveline Propulsion System for Dual Hybrid Passenger Vehicle

F. Wasbari^{1,2,3*}, R.A. Bakar¹, L.M. Gan¹, M.A. Salim^{2,3}, N.A. Hamid^{2,3} and S.G. Herawan⁴

¹Faculty of Mechanical and Automotive Engineering Technology, Universiti Malaysia Pahang, 26600 Pekan, Pahang, Malaysia.

²Fakulti Kejuruteraan Mekanikal, Universiti Teknikal Malaysia Melaka, Hang Tuah Jaya, 76100 Durian Tunggal, Melaka, Malaysia.

³Centre for Advanced Research on Energy, Universiti Teknikal Malaysia Melaka, Hang Tuah Jaya, 76100 Durian Tunggal, Melaka, Malaysia.

⁴Faculty of Engineering, Bina Nusantara University, Palmerah Jakarta 11480, Indonesia.

ABSTRACT

The study focused on investigating the pressure drop/loss of the hydro-pneumatic driveline propulsion system. Previous research has shown that there is a very high power loss in the hydro-pneumatic propulsion system. Therefore, this research is carried out to identify the behaviour, cause and strategy to overcome this problem. The Hydraulic Hybrid Vehicle (HHV) is a new technology under development to improve fuel efficiency in passenger vehicles. However, this system is still under research and development phase. There is still a great deal of uncertainty about the performance of this system. In this research, the functional schematic diagram of the charging and propulsion was designed and simulated by using Automation Studio software. The real-time data and pressure behaviour of hydro-pneumatic driveline propulsion obtained by running the system without load condition. As a result, the highest value of losses occurred at $(p_{sys} - p_1)$, stage 1, from the supply to the input of the valve. The value is around 68 to 69 bar and occurred at $p_{sys} = 220$ bar. $(p_2 - p_3)$ showed the lowest losses overall. The lowest pressure loss value occurred at $p_{sys} = 100$ bar, which is around 17 to 18 bar. The pressure drop happened to be high due to the improper selection of hose diameter represented by $(p_{sys} - p_1)$. The loss of $(p_1 - p_2)$ was due to diameter and angle of connector too sharp that caused disturbance to the flow and p_3 is developing back pressure at return line. The stage pressure monitoring was used to narrow down the root cause, and some papers have been used to validate the behaviour.

Keywords: pressure drop; hybrid hydraulic; hydraulic propulsion

1. INTRODUCTION

A hybrid technology is a system that combined two or more technologies to achieve an efficient system. In this era of technology and globalisation, the hybrid system is now growing in popularity in the automotive field due to its advantages in terms of the environment, fuel saving, and better efficiency compared to a conventional car. In automotive, hybrid means the vehicle that uses two or more different power sources or propulsion that are work together to move the vehicle or create power. Hybrid hydraulic technology is famous among heavy vehicles such as buses and garbage truck, and this technology is still in research and development to be applied to the passenger car [1].

The hydro-pneumatic hybrid is a new hybrid system that has been introduced. It combines the internal combustion engine (ICE) and hydraulic system for the propulsion and hydro-pneumatic system for the energy source. The hydro-pneumatic driveline consists of several sub-systems: propulsion, regenerative system, storage, transmission, and control system [2]. Propulsion is a mechanism to move a vehicle. Regenerative system or known as a regenerative braking is a

system that captures the energy loss during the braking or decelerates in the form of kinetic energy and changes the energy to compression energy. The compression energy is then be stored in a hydraulic-pneumatic accumulator in the form of the potential energy. When the energy required by a car to accelerate, the stored energy will be a channel to the hydraulic motor to rotate the wheel.

The conventional vehicle will always burn gas although in idle condition [3]. Hydro-pneumatic hybrid offers a few advantages and disadvantages over the other conventional and hybrid vehicle. Hydro-pneumatic hybrid requires less energy conversion compare to an electric hybrid vehicle. An electric hybrid will convert kinetic energy to electrical energy and then chemical energy to store in the battery. For the hydro-pneumatic hybrid, converted kinetic energy to pressure energy and stored it in the storage. Due to less energy conversion by hydro-pneumatic hybrid, this leads to higher efficiency than electric vehicles [4]. Besides its advantage, the hydro-pneumatic hybrid also has its disadvantages. Besides the weight is heavy, the system also lacks of energy density and suitable for city drive only. Although hybrid technology is seen to save fuel, this technology is still in the research and development phase because of its suitability to be applied to passenger vehicles.

Previous research has developed a propulsion system for dual hybrid by using a basic principle to energise the driveline. An 8 cm³/rev displacement hydraulic motor worked as propulsion component. Energy is stored in a storage unit called an accumulator. There are two types of accumulators, high pressure and low pressure. This rig can run a forward (clockwise) and reverse (counter clockwise) process. However, this system produced a very low efficiency of below 40%. The system pressure is set from 100 bar to 220 bar, but it is reduced to the apparent point at the inlet of the hydraulic motor [5]. The research group suspected that it caused by high-pressure drop in some parts of the system. Hence, a detailed investigation is needed to prove the root cause of this problem. This time, the pressure and flow will be monitored for every stage of the operation. It will create a profile of pressure losses, and it will be used to find the root cause.

2. LITERATURE REVIEW

The advancement of hybrid technology has become predominant in the automobile industry. The innovation demonstrates positive feedback which improves vehicle efficiency, fuel economy and greener technology. One of the types of hybrid vehicles is a hydro-pneumatic hybrid. The hydro-pneumatic hybrid car is a compounding of two or more types of propulsion sub-systems that work in a vehicle. This concept is not new because it has been applied to the heavy vehicle as part of its hybrid system. However, using the concept of hydro-pneumatic on passenger automobiles is an innovation [6]. The hydro-pneumatic hybrid technology uses a combination of the internal combustion engine (ICE) sub-system as the main propulsion. Hydraulic sub-system as a hybrid propulsion unit and hydro-pneumatic accumulator as a power source. During operation, the energy is stored in the accumulator. Once the energy in the accumulator is low, through braking and coasting, the regenerative braking is activated to charge the accumulator. ICE and hydraulic propulsion are combined by an additional device [7]. The concept utilizes energy losses in braking and recovers into useful energy [8]. Normally, the hydro-pneumatic system is applied by the heavy hybrid vehicle as secondary propulsion [9-12]. However, it is also widely used in the suspension system [13].

Bosch, Eaton, and Parker are the giant companies actively developing to support hydraulic hybrid technology. Bosch has produced the hydrostatic regenerative braking system and estimated fuel consumption improvement to 25% in urban refuse trucks or buses[14]. Eaton (2007) wrote that the company collaborated with the US Environmental Protection Agency (EPA) and US Parcel Service (UPS) to develop a hydraulic launch assist for a series-hybrid diesel

truck system [15]. The company claimed a 60% to 70% fuel economy and a 40% reduction of carbon emission in the stop-and-go delivery. Parker produced hydraulic hybrid drive transmission known as the RunWise to refuse truck [16]. California Water Resource Board has confirmed that the technology saves fuel economy and efficiency by up to 50%. Eaton produces a hybrid system for refuse trucks and buses that operate in the stop-and-go duty cycle [17]. The company estimated a 20% to 30% improvement in fuel consumption. The actual driving shows that the lowest fuel savings are 20%, while the highest is 70%. Later, Flaig stated that Bosch later collaborates with PSA Peugeot Citroen to produce a passenger car prototype that can reduce fuel consumption by up to 45% called Hybrid Aircar [18].

Since hydraulics are the main driver in this hybrid system, most of the components used are based on hydraulic. The energy source is obtained from a dry nitrogen compression process called a hydro-pneumatic accumulator. This compressive force is known as pressure. The pressure stored in the accumulator will be passed from the energy storage to the hydraulic motor to produce forward movement. The same concept is used to create backward motion, but the direction of flow of fluid will be changed in a different order. The directional valve controlled the direction. All these liquid will be stored in a low-pressure tank. This hydro-pneumatic hybrid concept is planned to operate at a low speed around a maximum of 60 km/h. If higher performance is required, the propulsion system will be changed to ICE by the controller device.

Hydraulic was chosen as the power transfer medium due to the interesting features found in this system. It produces an enormous power density. Power density is a power characteristic related to the ability of the system to move the vehicle. However, the system is lack in producing energy density. Energy density is a characteristic that drives the car over some time or a long distance. A significant thing that needs to be considered in this system is energy losses. It happens due to pressure, kinetic, and potential [19], [20]. Pressure drop is the difference in total pressure between two points in a fluid-carrying network. When a liquid material enters one end of a piping system and leaves the other, pressure drop or pressure loss will occur. The head produces kinetic losses in speed, while potential losses are caused by the head height difference between the input and output parts. Nowadays, most of the current literature considers two more losses called major and minor losses. Major losses refer to the loss of energy due to friction in a pipe or hose. Minor losses refer to losses caused by components and fittings. All disturbances to the flow that occurs in this closed system will result in minor losses. For example, bending disturbances on the 90-degree elbow pipe and contraction/expansion disturbances that appear on the valve. The equation related to energy losses are presented as following Equations (1) to (4).

Bernoulli equation for viscous flow, When the viscosity of the fluid is taken into account total energy head:

$$\text{Total energy, } H = \frac{v^2}{2g} + \frac{p}{\rho g} + z \quad (1)$$

To restore equality, some scalar quantity to the right side of this inequality must be added:

$$\frac{v_1^2}{2g} + \frac{p_1}{\rho g} + z_1 = \frac{v_2^2}{2g} + \frac{p_2}{\rho g} + z_2 + \Delta h_{ls} \quad (2)$$

The hydraulic loss between two different cross-sections along the pipe is equal to the difference of total energy for this cross-section:

$$\Delta h_{ls} = H_1 - H_2 \quad (3)$$

Head loss is expressed by Darcy-Weisbach equation:

$$h_l = f \frac{L v^2}{D 2g} \quad (4)$$

The effect of this energy loss should not be underestimated as it is closely associated with the power and torque produced by the system. If the energy loss in the system is high, the torque and power generated by the system will be low, thereby reducing the efficiency of the system. Less efficient means that the value of the given supply is high, but the value of the resulting production is low. In high-pressure hydraulic systems, losses can also occur due to several additional criteria such as leakage, component selection and even hose selection [21-24].

Hydraulic fluid leaks are physical and can be detected despite being low. Usually, wet areas are the spots where leaks occurred. It can be overcome by seeing the source of the leak and taking appropriate measures according to the causes of the leak. Proper component selection can reduce disruption to fluid flow, and energy loss can be reduced. For example, many types of valves can be used for flow control. The value of the flow coefficient (C_v) determines the valve losses, where the larger the valve opening, the larger the C_v value. The higher the difference of C_v value than the bore diameter, the higher the pressure loss and low in flow rate. Next is the selection of hose diameter. Each hydraulic hose size has limitations when it comes to how much flow can be pushed through the inside diameter (ID) without adversely affecting both working pressure on the input side and back pressure on the return side of the system. So, choosing the proper diameter hose is critical to eliminate inefficiencies. Any mistakes will result in heat generation and excess of back pressure in the motor. All these criteria must be taken into account when designing the hydraulic system.

3. RESEARCH METHODOLOGY

Overall, the design and application of this system is based on the dual hybrid concept, which is a combination of ICE and hydraulic propulsion. Yet this hybrid system is isolated and controlled sequentially with the help of a controller. For this research, emphasis was put on hydro-pneumatic kinematics, as shown in Figure 1. The scope of this study is focused on the drive system and excludes regenerative braking.

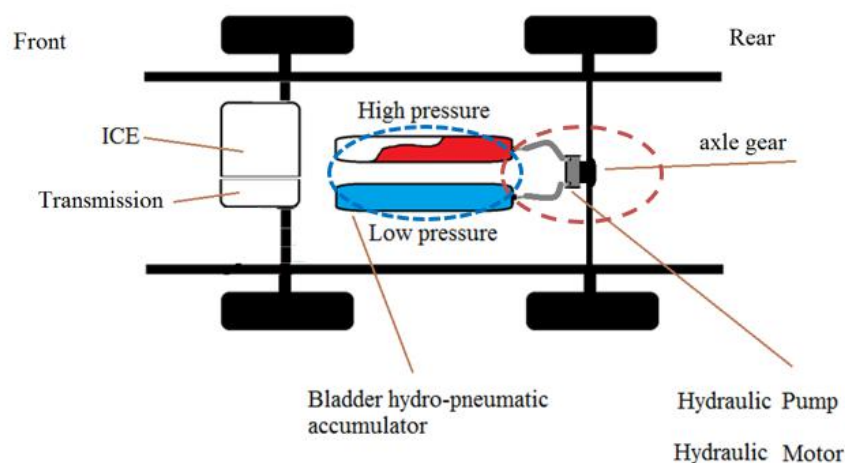

Figure 1. Dual hybrid configuration.

3.1 Design and Simulation of Functional

According to the operational requirements, all required components are illustrated in Figure 2. The powertrain is used as a component which resembles regenerative braking. The goal is to generate pressure prior to being stored in the high pressure accumulator. This pressure energy is piped into the hydraulic motor by valves. There are two kinds of valves: the directional control valve (DCV) and the flow control valve (FCV). The hydraulic motor outlet has little pressure. It is stored in a regular reservoir.

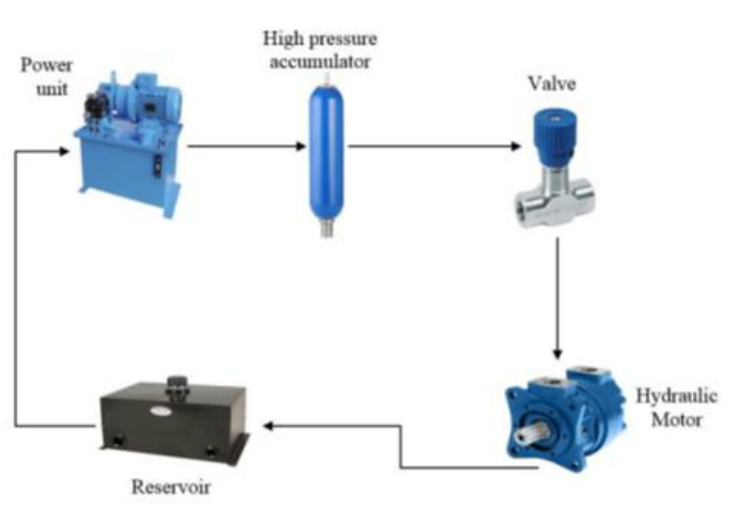

Figure 2. Pictorial diagram.

Based on the pictorial diagram, the actual hydraulic schematic is designed and then simulated. The purpose of this simulation is to ensure that the entire system and components are operating as intended. As a reminder, simulations are not performed as a parametric study because this research is linked to experimental work. The hydraulic schematic is shown in Figure 3. It differed from the previous one because of the location of the manometer at each step of the flow. It was later used to generate a pressure profile. The p_{sys} acts as a pressure system. p_1 is placed before the DCV, p_2 is placed at the inlet portion of the motor and p_3 is placed at the output portion of the motor to the tank.

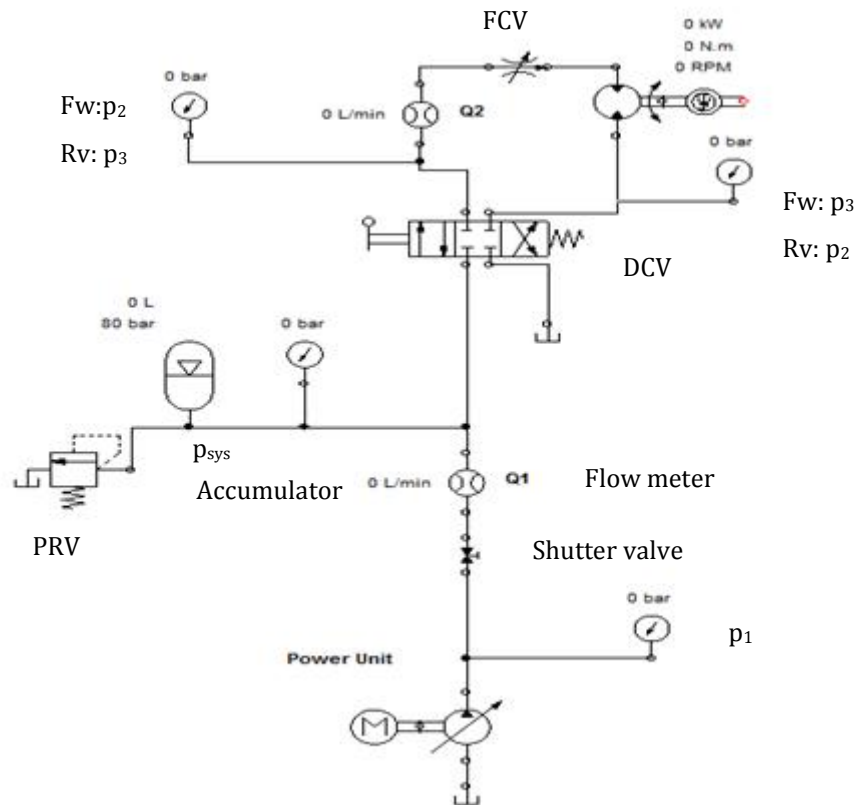

Figure 3. Hydraulic schematics diagram.

3.2 Fabrication, Installation and Testing

The fabrication process is divided into two parts, namely, the power unit and the rig. The components used for the rig are 8 cm³/rev hydraulic motor, 5 mm ID hydraulic hose, 32 L hydro-pneumatic accumulator. Measurement instruments such as pressure sensor, flow sensor, temperature and speed sensor are from Hydrotechnik controlled by MultiSystem 5070 Plus data acquisition unit (DAQ). Refer to Figure 4.

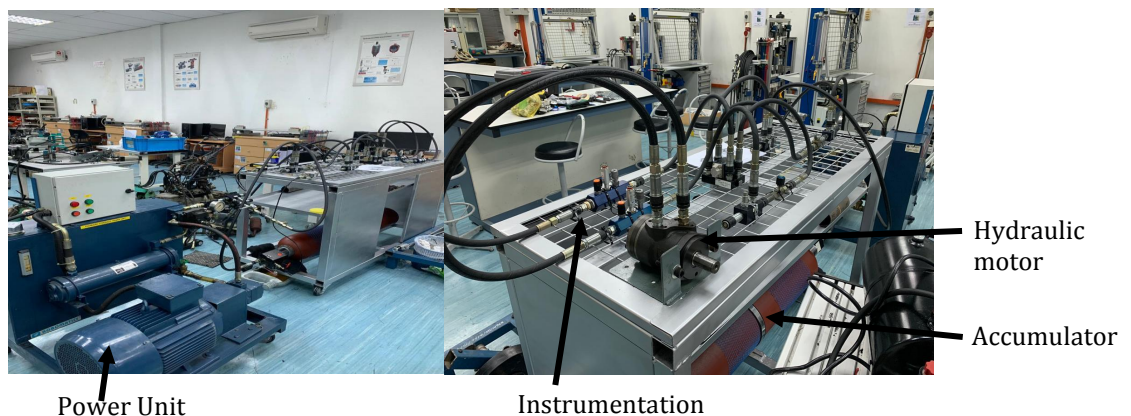

Figure 4. Test rig for testing.

The trials or experiments were performed in real time. Independent variables are in real time, and other parameters are defined as dependent variables. The hydraulic motor was moved clockwise to mimic the forward movement of a car, while the counterclockwise movement

represents the reverse movement. This direction change was done by activating the DCV. The default setting for pre-charge pressure in the hydro-pneumatic accumulator is 80 bar, so the p_{sys} setting starts from 100 bar to 220 bar.

4. RESULTS AND DISCUSSION

Figure 5 shows the relationship between fluid power parameters and time for load-free conditions set at 100 bar storage pressure and counterclockwise rotation. Load-free means there is no load attached at the end of the hydraulic motor. The hydraulic motor shaft rotates freely. The profiles are colour coded, and the scales are shown on the y-axis. From the graph, the experiment results can be divided into two (2) types of profile. The first is the increase in temperature at TEMP 1 and TEMP 2. Meanwhile, the other is the increase in p_1 , p_2 , p_3 , Q_1 Q_2 and n_1 . TEMP 1 and TEMP 2 during the rest phase were constant. When the discharge mode is activated, the temperature increases gradually because of high-pressure hydraulic oil movement to low pressure. During the action, the oil molecules will collide with each other, resulting in a rise in temperature. Coupled with friction between the oil surface and the hose surface, the increase in temperature becomes more pronounced. However, because the oil medium is liquid-based, the ability of an oil to absorb temperature is faster and higher than solid material. Although there is a gradual increase in temperature, in return, the rise in temperature is slight at less than 0.5 degrees Celsius. This is because the relative pressure between liquid, 100 bar and pre-charge, 80 bar is small. Then, after discharge, the phase will return to the rest phase. However, it was found that the temperature remained increased in this phase because the heat generated was latent. It takes time to transfer from the liquid medium to the solid on the outer surface where the temperature was taken.

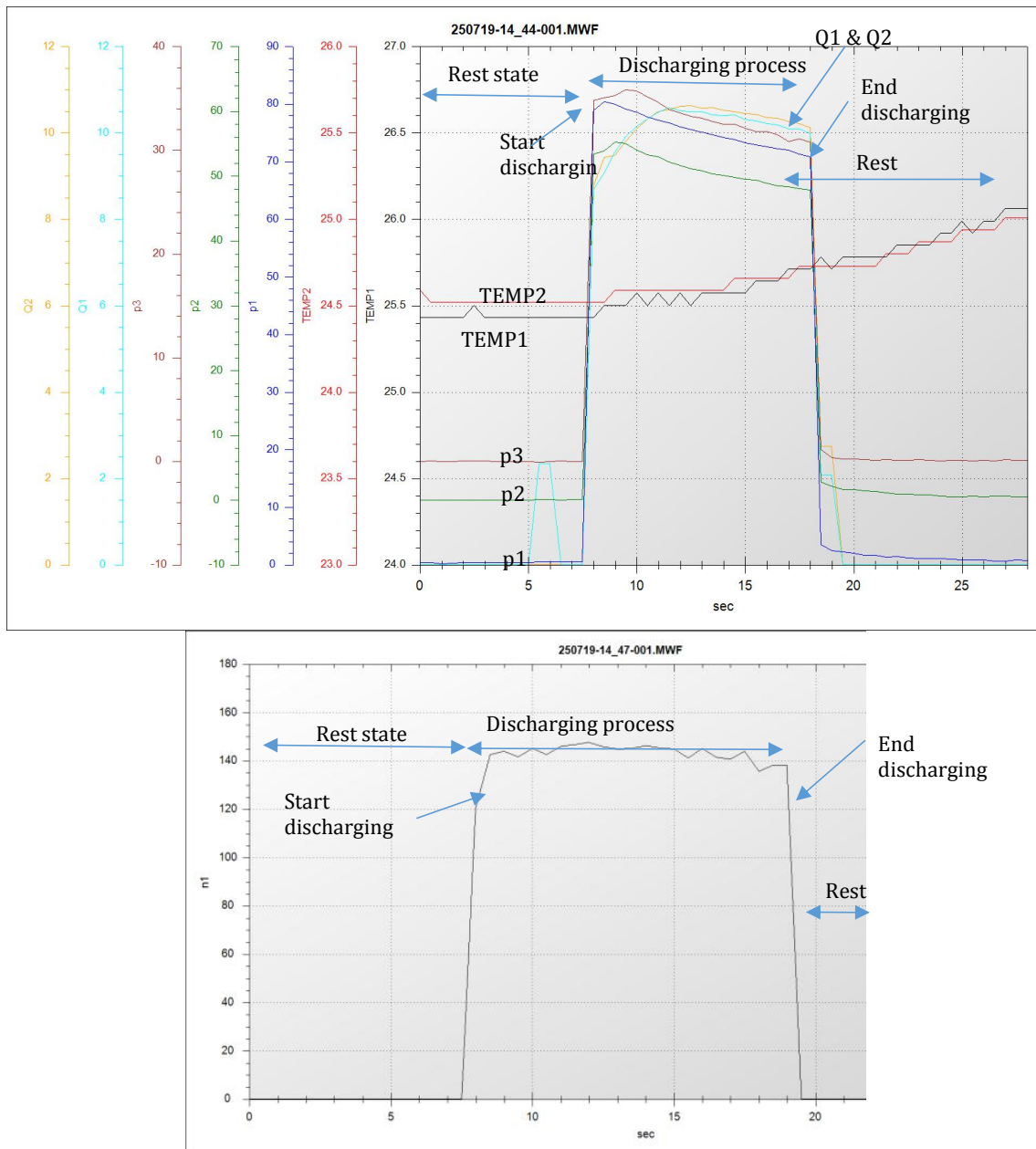

Figure 5. Real-time behaviour at 100 bar pressure with counterclockwise (CCW) rotations of hydraulic motor (minimum pressure setting).

At rest, p1, p2, p3, Q1 and Q2 are unchanged. When the discharged process begins, an increase in pressure and flow rate will occur. Based on the y-axis scale, the highest pressure increase is at p1, which is the current pressure in the output part of the storage tank. Although the setting pressure is 100 bar, the output obtained is less than the stored value. This is due to the process of forcing pressure from the bladder and the loss of the column at the outflow of the storage tank. The graph recorded a loss of 18% pressure in this stage. The pressure then becomes lower at p2, on the hydraulic motor input due to some more losses. Some of the pressure has been changed to free-load power on hydraulic motors, causing it to be much lower than the input. The higher the pressure-power conversion, the higher the difference. During discharge, the pressure decreased for each point p1, p2, and p3. This change is reflected in the descending slope in the diagram. Upon completion of the discharge phase, based on the y-axis scale, the pressure will return to 0 bar again at the rest phase.

For clockwise rotation, slight changes in the assigned parameter have been made where p3 is set in the motor input, p2 is in the motor output. Similarly, the flow rate, Q2, becomes the input while Q1 is the output. The changes are necessary because the experiment uses the same test rig, but the rotational direction change is done by using the directional control valve as described in chapter 3. By using the directional control valve, significant changes to the test rig can be avoided. This means that the accuracy of the testing rig is maintained and guaranteed.

Figure 6 has shown the relationship between fluid power parameters and time for load-free conditions set at 100 bar storage pressure and clockwise rotation. Not much change to the profile of the results obtained. However, the value of each parameter varies between clockwise and counterclockwise. It was found that the loss of pressure at p2 for the clockwise rotation is slightly lower than counterclockwise. The value is significant because it determines how much pressure enters the hydraulic motor and how much energy can be converted to rotational power. The higher the p2 value entering the hydraulic motor, the greater the chance of generating high power. However, in the free-load case, the effect of converting pressure energy to rotational force is not seen as it does not involve the effect of load resistivity. Later, with a load of resistivity, the effect of energy conversion can be seen more clearly.

For the rotational speed n1, RPM of the hydraulic motor starts from rest 0 RPM and is closely related to the flow rate. During the discharge process, hydraulic oil will flow from the storage tank to low pressure. The higher the flow rate it will result in the higher the rotational speed. The relationship can be seen from the graph above. Since the flow rate is constant, then the resulting rotational speed is consistent throughout the discharge process. This is evidenced by the equation $Q = V_d \cdot N$, where Q is the flowrate, V_d is the displacement volume and N is the rotational speed. In the state of fixed displacement, the V_d is fixed. In the event of a change in flowrate, the rotational speed will also change. If Q value increases, the value of N also will increase and vice versa. The relationship is proportional. After completion of the discharge process, the motor will be at rest again; 0 RPM. This causes the flow rate also to be zero.

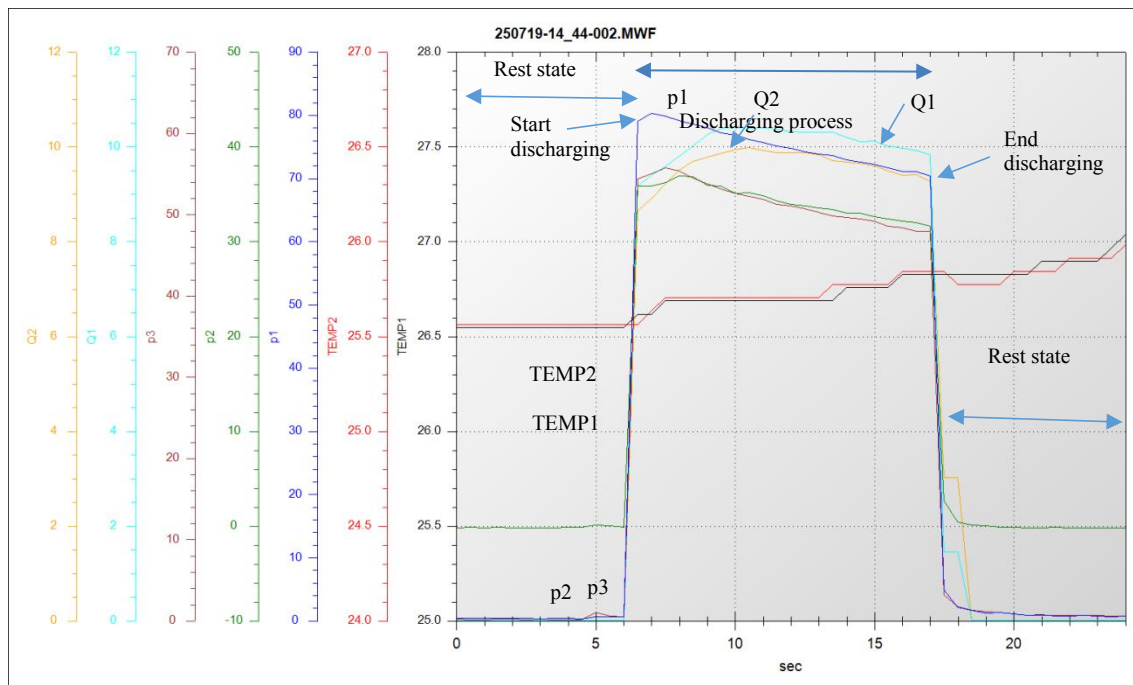

Figure 6. Real-time behaviour at 100 bar pressure with clockwise (CW) rotations of hydraulic motor (minimum pressure setting).

When storage pressure was increased to 220 bar, the relationship between all the time parameters was shown in Figure 7. A huge and significant difference appeared when compared to the profile obtained at 100 bar experiment. Most notable are the rise response of pressure, discharge sloop, pressure losses, pressure sloop, flowrate sloop, discharging time and the rotational speed gradient. At the initial stage, the response time pressure and flow rate at point A1 to A2 are speedy. It forms a vertical line without a significant gradient when compared to the response at storage pressure 100 bar. This occurs due to the high pressure causing the nitrogen-containing bladder to undergo strong compression. The strong compression will push the hydraulic fluid out of storage faster when the valve is opened.

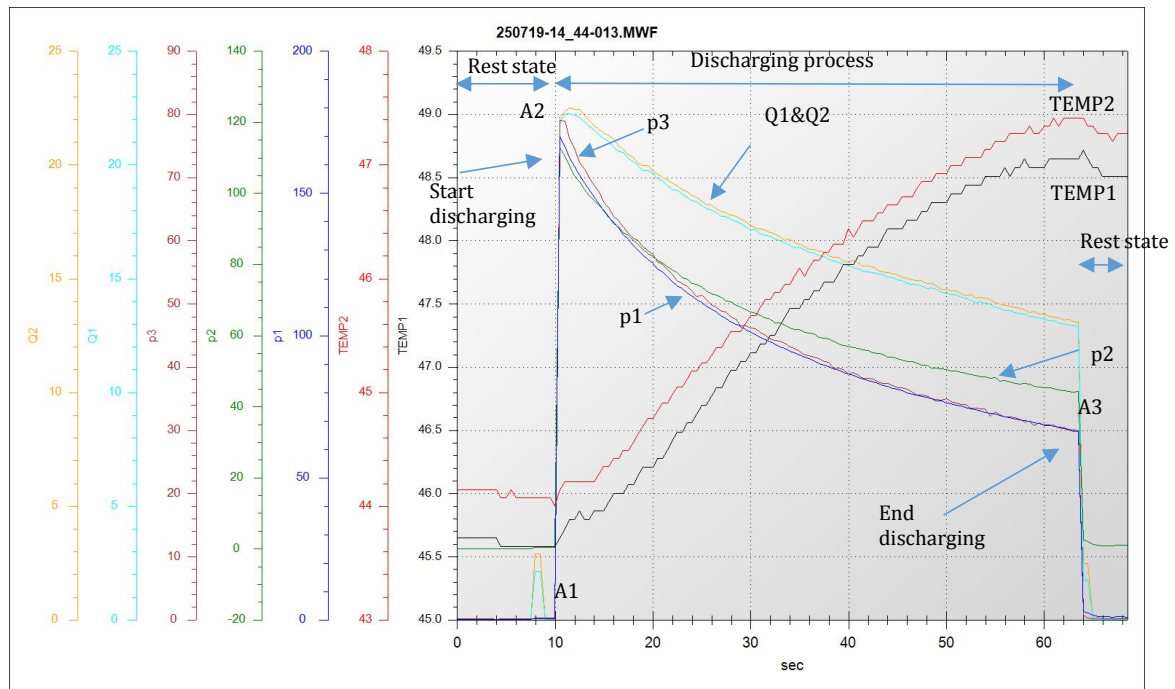

Figure 7. Real-time behaviour at 220 bar pressure with counterclockwise (CCW) rotations of hydraulic motor (maximum pressure setting).

After the response reached point A2, the discharge process has taken place up to point A3. There is a very significant difference when compared to the profile on the 100 bar storage. At 220 bar, the profile started high then decreased significantly. This reduction results in a significant gradient. The profile from point A2 to A3 can be divided into 3 parts: beginning, middle, and end. The angle of the profile represented by the equation, $\partial p / \partial t$ indicates how fast the pressure changes over time. Or it is easier to say that it is related to the time taken for the pressure change from point A2 to A3. Based on the profile rather than the value, the pressure at p1, p2 and p3 showed $\partial p / \partial t$ almost the same initially, but p3 shows a noticeable change starting at the middle to the end. What distinguishes the three profiles is the location of the pressure gauge. Pressure p1 is at the storage output, p2 is before entering the hydraulic motor, and p3 is at the motor output. Thus, at the initial stage, all three profiles show equally rapid pressure changes. However, the pressure changes at the p3 location become slower at the end of the discharge process. Another essential thing to note is the difference in value between p1, p2 and p3, which is represented by Δp_{12} and Δp_{23} . Δp_{12} refers to losses that occur from p1 to p2. The higher the value of this loss, the less performance is produced, and the less efficiency is generated. This type of situation should be avoided. While Δp_{23} refers to the loss of pressure to produce performance. The higher this value, the higher the performance generated by the hydraulic motor. These performances will determine the motor's efficiency and, in turn, it affects the result of system efficiency.

The same behavior can be seen in the flow rate, where it started with a fast response at an early stage, then enters the discharge phase. There is a flowrate change during discharge divided into 3 phases: the beginning, middle, and end. This change is represented by $\partial Q/\partial t$. It refers to how fast the flowrate changes from point A2 to A3. $\partial Q/\partial t$ in the initial phase is high, then decreases in the middle phase and becomes low in the end phase. It was found that there was no loss between points Q1 and Q2. Q1 refers to flowrate before entering the hydraulic motor, and Q2 refers to flowrate after entering the hydraulic motor. There are no significant changes in the flow rate for both locations. Based on the theory, flowrate is directly proportional to the rotational speed, and it is evidenced from the above profile where in terms of profile shape, it is the same. Rotation speed n_1 indicates fast response, then undergoes discharge and then returns to rest state. The gradient on the profile shows how fast the rotational speed changes from one point to another and is represented by $\partial N/\partial t$. The relationship between pressure, flow rate and rotational speed is indicated by the discharge time, where high pressure will store more volume. When a discharge occurs at a specific flow rate value and rotational speed at higher pressure, such as 200 bar, it will take longer for the hydraulic motor to rotate before it stops. The value of discharge time, t_d at 200 bar storage is longer than the discharge time at 100 bar storage. If adapted to the vehicle system, the running time for the vehicle's propulsion system will be higher, providing long-distance travel.

For storage with a pressure of 220 bar, the clockwise rotation speed also shows a relatively significant profile because it experiences a substantial decrease in gradient compared to hold at 100 bar. It started with a fast response when the valve is opened, then discharging starts from the 8th second until the 62nd second, which is about 54 seconds of movement. Then, the situation returns to a rest state. The discharge process for this rotational speed also undergoes 3 phases of pressure change, namely $\partial p/\partial t$ high, medium in the middle and low at the end of the process. The same situation applies to the flow rate as well as the rotational speed. Refer to Figure 8.

If viewed in terms of automotive applications, at no-load conditions, and the same valve openings, the values of pressure, flow, and rotational speed will change to 3 phases; high, medium and low. This results in difficulties to control the output power, torque and even speed of the vehicle at stable condition. This requires a more effective control system that focuses on output stability as well as speed. This effect is not very significant at a storage pressure of 100 bar but very significant at a storage pressure of 220 bar. At a storage pressure of 100 bar, the pressure and flowrate show a slight gradient from the beginning to the end of the discharge process, while the rotational speed can be said to be stable from start to finish. One thing that distinguishes these two pressure storage conditions is the reaction inside the bladder accumulator. At 100 bar storage - 80 pre-charge, the bladder experiences minimal compression due to 20 bar pressure difference. The result of this compression can only store a small amount of capacity volume. When the valve is opened, most but not all of the capacity volume will flow to the hydraulic motor, forming another volume called effective volume. This effective volume is the amount of volume used to rotate the hydraulic motor. Ineffective volume capacity will reside in the excess space between the bladder and the inner casing of the accumulator. Although this value is small, it is important and a determinant of volume efficiency, which affects the system efficiency. At 220 bar storage - 80 pre-charge, the bladder experiences a significant compression rate due to 140 bar pressure difference. When given greater pressure, the behavior of the bladder that stores energy in the accumulator will change. In other words, this bladder accumulator affects the pressure change and affects the hydraulic movement profile of the motor. This matter requires a more detailed and thorough investigation in the future.

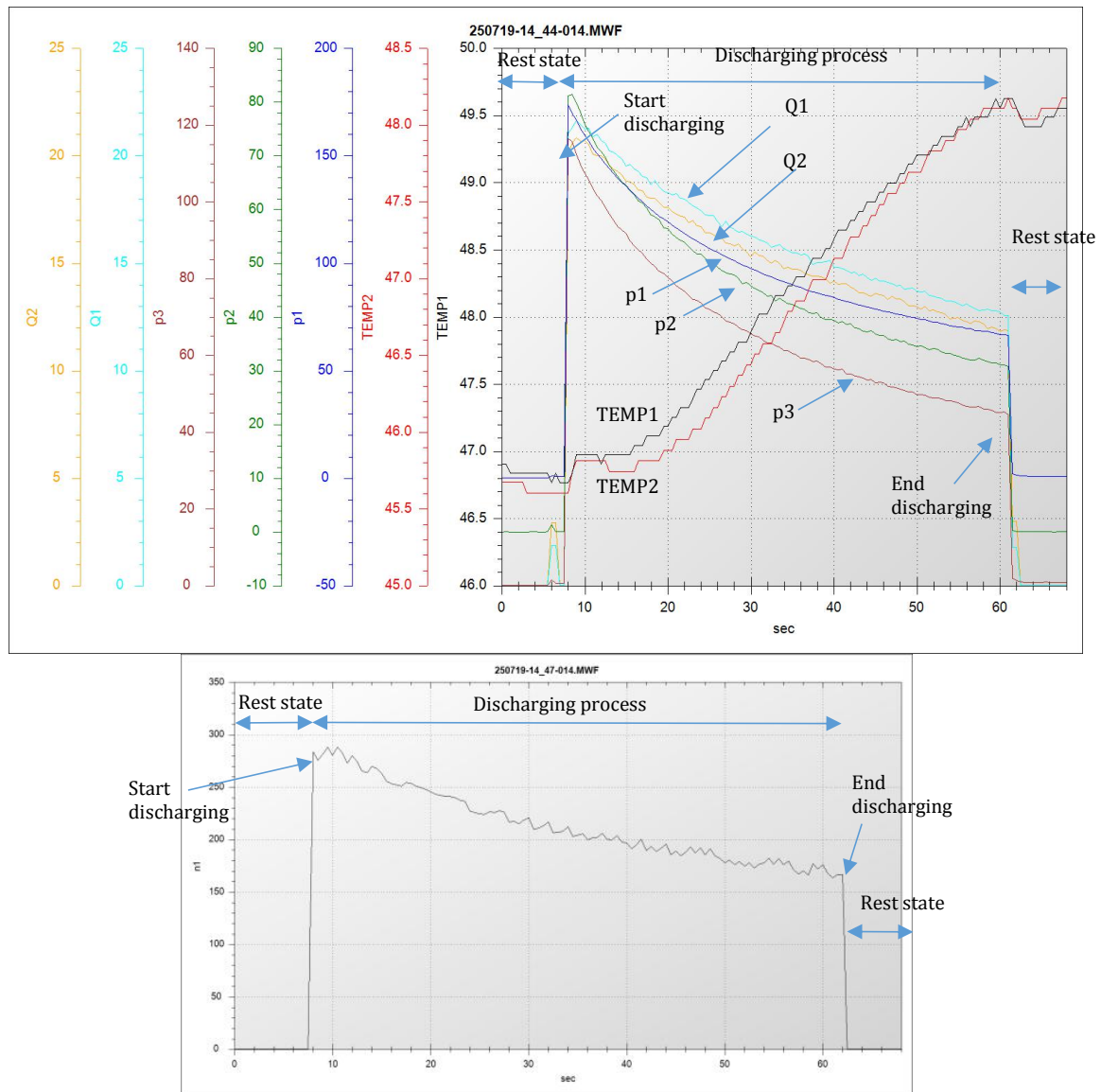

Figure 8. Real-time behaviour of at 220 bar pressure with clockwise (CW) rotations of hydraulic motor (maximum pressure setting).

4.1 Pressure Losses Curve Behavior

Figure 9 has shown the pressure profile for each stage of the hydraulic system. The profile is similar between CW and CCW. The highest pressure is the system pressure, P_{sys} . This pressure was set at the output of energy storage. In other words, it is the supply pressure. Pressure decreased in the first stage, p_1 . Then it shrinks more before entering the motor inlet and finally exiting the motor to the reservoir. From this profile, analysis was performed to obtain pressure losses ($p_{sys} - p_1$), ($p_1 - p_2$) and ($p_2 - p_3$).

Table 1 showed the value of pressure drop for each stage in the direction of CW and CCW. Pressure drop readings did not change much between CW and CCW. All three stages show a similar patent. The higher the p_{sys} value, the higher the pressure loss that occurred. The highest value of losses occurred at ($p_{sys} - p_1$), which is stage 1 from the supply to input of valve. The value is around 68 to 69 bar and occurred at $p_{sys} = 220$ bar. ($p_2 - p_3$) shows the lowest losses overall. The lowest pressure loss value occurred at $p_{sys} = 100$ bar, which is around 17 to 18 bar. For stage 1, between P_{sys} and p_1 , the losses are enormous. These occurrences are significant. Besides pressures are drop, the flow rates also drop. These circumstances indicated such a

behavioural loss caused by the improper selection of hoses [26]. But sometimes, it is a combination of more than one element/component. Based on the schematic, two parts may result in these pressure losses: hydraulic connector and hose. These pressure losses occur due to minor losses in the connector, and the hose size is too small [25]. Although the name indicated minor losses, the value can be greater than the friction losses in some occurrence. ($p_{sys} - p_1$) showed the behaviour of hose diameter too small and high value of connector coefficient loss [26], [27]. Stage 2, between p_1 and p_2 , the components involved are DCV and hose. Thus, ($p_1 - p_2$) showed the behaviour of C_v valve pressure loss [27]. ($p_2 - p_3$) was useful pressure loss. The pressure losses converted to mechanical power. The value is small due to the lower volume displacement and low RPM [28]. Usually, without load, the rotational assume to be ideal. Therefore, the power, torque and RPM are low. p_3 is the return line to the tank. It is too high due to backpressure. The exit hose should be larger to avoid back pressure [26].

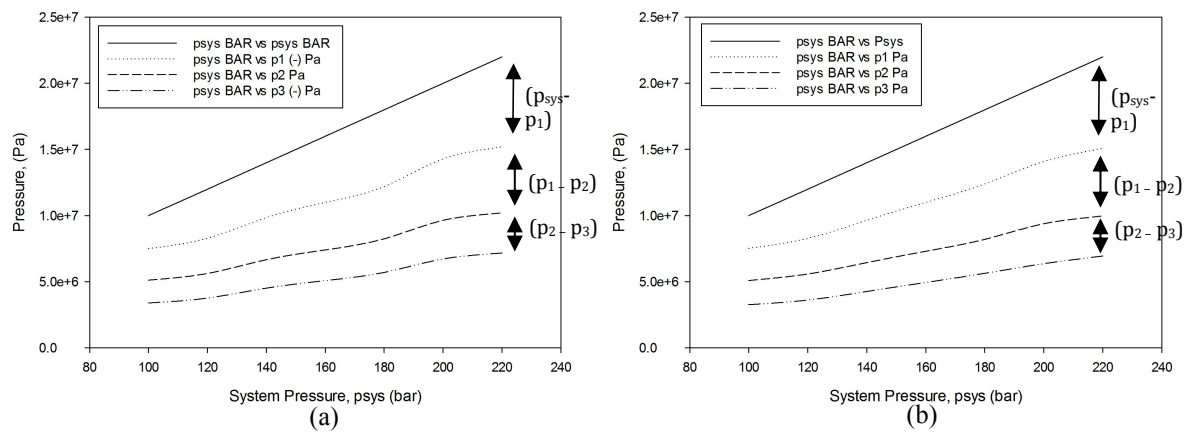

Figure 9. Pressure profile (a) CW and (b) CCW for every stage of the hydraulic system.

Table 1 Pressure drop for CW rotation

Pressure System bar	CW				CCW			
	($p_{sys} - p_1$) bar	($p_1 - p_2$) bar	($p_2 - p_3$) bar	p_3 bar	($p_{sys} - p_1$) bar	($p_1 - p_2$) bar	($p_2 - p_3$) bar	p_3 bar
100	25	23.8	17.3	33.9	24.8	24.3	18.3	32.6
120	37.2	26.6	18.6	37.6	37.3	26.9	19.7	36.1
140	41.6	31.8	21.5	45.1	43.7	31.9	21.8	42.6
160	50	36	23.2	50.8	50	37	23.6	49.4
180	58	39.6	25.4	57	56	42	25.7	56.3
200	57	46.6	29.2	67.2	59	47.2	30.2	63.6
220	68	50	30.3	71.7	69	51.3	30.3	69.4

4.2 Strategy to Improve the System

In order to improve the system, there are several actions can be taken. First, change the hose to a larger inner diameter. It is better to use the proper method to choose the suitable diameter. Based on the result, the data obtained is enough to find the right diameter. It usually is referring to the flow rate and velocity of system fluid. Second, a new connector with a larger bore diameter and greater angle is required for the connector. The current connector uses a combination of low inner diameter and 90-degree elbow. So, the pressure losses became high.

Third, use a high flow DCV to reduce the disturbance in hydraulic flow. And lastly, choose a bigger return line hose to avoid backpressure.

5. CONCLUSION

This study managed to identify the root cause of pressure losses. It is due to the improper selection of hose diameter represented by $(p_{\text{sys}} - p_1)$. $(p_1 - p_2)$ represented diameter and angle of connector too sharp that caused disturbance to the flow and p_3 is developing back pressure at return line. The stage pressure monitoring was used to narrow down the root cause, and some papers have been used to validate the behaviour. The highest value of losses occurred at $(p_{\text{sys}} - p_1)$, which is stage 1 from the supply to input of valve. The value is around 68 to 69 bar and occurred at $p_{\text{sys}} = 220$ bar. $(p_2 - p_3)$ shows the lowest losses overall. The lowest pressure loss value occurred at $p_{\text{sys}} = 100$ bar, which is around 17 to 18 bar. Here, the author also came out with several strategies to improve the system. Perhaps this strategy can be used as a new design and rerun the experiment to validate the future results.

ACKNOWLEDGEMENT

This paper was made possible by a scholarship from the Ministry of Higher Education and Universiti Teknikal Malaysia Melaka. Authors also would like to take this opportunity to thank Universiti Malaysia Pahang for the opportunities and facilities provided to complete this study.

REFERENCES

- [1] Boretti, A., Zanforlin, S. SAE Int. Hydro-Pneumatic Driveline for Passenger Car Applications. (2014).
- [2] Wasbari, F., Bakar, R., A., Gan, L., M., Tahir, M., M., Yusof, A., A. Renew Sustain Energy. A review of compressed-air hybrid technology in vehicle system. vol **67**, (2017) pp.935–953.
- [3] Rahman, S., M., A., Masjuki, H., H., Kalam, M., A., Abedin, M., J., Sanjid, A., Sajjad, H. Energy Convers Manag. Impact of idling on fuel consumption and exhaust emissions and available idle-reduction technologies for diesel vehicles - A review. vol **74**, (2013) pp.171–182.
- [4] Nayak, H., K., Goswami, D., Hablani, V. Int J Automob Eng Res Dev. Technical Review on Study of Compressed Air Vehicle (CAV). vol **3**, no 1 (2013) pp.81–90.
- [5] M., A., A., M., Yusoff, "Experimental of free-load hydro-pneumatic propulsion system", Universiti Teknikal Malaysia Melaka, (2018).
- [6] P. Achten, G. Vael, M. I. Sokar, T. Kohmäscher, "Design and Fuel Economy of a Series Hydraulic Hybrid Vehicle," in Proc. JFPS Int. Symp. Fluid Power, (2008) pp.47–52.
- [7] U. Diego-Ayala, "An Investigation into Hybrid Power Trains for vehicles with regenerative braking," (2007).
- [8] S. J. Clegg, "A Review of Regenerative Braking Systems," UK, (1996).
- [9] Bravo, R., R., S., De Negri, V., J., Oliveira, A., A., M. Appl. Energy. Design and analysis of a parallel hydraulic - pneumatic regenerative braking system for heavy-duty hybrid vehicles. (2018).
- [10] Reddy S. C., Rayudu G. V. N., Carolina N. SAE Int. Design of a regenerative braking system for city buses. (1989).
- [11] Kepner, R., P. SAE Tech Pa. Hydraulic Power Assist – A Demonstration of Hydraulic Hybrid Vehicle Regenerative Braking in a Road Vehicle Application. no. 2002-01–3128, (2002).
- [12] W. J. Midgley, D. Cebon, "Comparison of regenerative braking technologies for heavy

- goods vehicles in urban environments,” in Proc. Inst. Mech. Eng. Part D J. Automob. Eng., (2012) vol. **226**, no 7, pp.957–970.
- [13] Francisco, J., Heck, F., Perondi, E., A. SAE Tech Pap Ser. Design of a pneumatic regenerative braking system design of a pneumatic regenerative braking system. (2005).
- [14] Rexroth's hydraulic hybrid systems to be highlighted at HTUF, Bosch Rexroth website: Press release, 2009.
- [15] EPA showcase new fuel-saving hydraulic hybrid UPS delivery vehicle that will be road-tested in Cleveland, Eaton website: News releases, (2007). [Online]. Available: <http://www.eaton.com/Eaton/OurCompany/NewsEvents/NewsReleases/98065722>. [Accessed: 15-Oct-2015].
- [16] Parker Hannifin hydraulic transmission outperforms proposed EPA emissions regulations for heavy-duty trucks,” Parker website, (2015).
- [17] S. Deutsch, “Eaton launches hydraulic hybrid retrofit program for refuse trucks,” in Green Car Congress website, (2010). [Online]. Available:<http://www.greencarcongress.com/2010/01/eaetnhla-20100122.html>. [Accessed: 15-Oct-2015].
- [18] F. Flaig, “Bosch hydraulic hybrid: practical and fun to drive,” Mobility Solutions, (2013). [Online]. Available: <http://www.boschpresse.de/presseforum/details.htm?txtID=6164&locale=en>. [Accessed: 15-Oct-2015].
- [19] Savi, V., Knežević, D., Mitar, L., Karanović, V. J Mech Eng. Determination of Pressure Losses in Hydraulic Pipeline Systems by Considering Temperature and Pressure. vol **55**, (2009) pp.237–243.
- [20] Cristescu, E., C., Dumitrescu, E., C., Hidraulica. Considerations on Energy Losses in Hydraulic Drive Systems. no. 1, (2016) pp.36–46.
- [21] M. Huova, A. Aalto, M. Linjama, K. Huhtala, “Study of Energy Losses in Digital Hydraulic Multi-Pressure Actuator,” in The 15th Scandinavian International Conference on Fluid Power, SICFP'17, (2017) pp.214–223.
- [22] Zardin, B., Cillo, G., Rinaldini, C., A., Mattarelli, E., Borghi M. Energies. Pressure Losses in Hydraulic Manifolds. vol **10**, issue 3 (2017) pp.310.
- [23] Mokhtarzadeh M. R. Dehghan, Ladommatos N., Brennan T. J. Appl Math Model. Finite element analysis of flow in a hydraulic pressure valve. vol. **21**, no. 7, (1997) pp.437–445.
- [24] Evans, C., W. Polymer Testing. Testing requirement for hydraulic hose. vol **1**, Issue 1 (1980) pp.39-49.
- [25] F. Wasbari, R. A. Bakar, L. M. Gan, A. A. Yusof, Z. A. Jafar, “Simulation of storage performance on hydropneumatic driveline in dual hybrid hydraulic passenger car,” in MATEC Web Conf., vol. 90, (2017) pp.1052.
- [26] Friction loss impacts on hydraulic power, hydra-tech.com website, (2016). [Online]. Available: <https://www.cejn.com/en-us/guides--support/in-the-know/avoiding-pressure-loss-in-hydraulic-systems/>. [Accessed: 20-May-2021].
- [27] M. Ketonen and M. Linjama, “High flowrate digital hydraulic valve system,” in The Ninth Workshop on Digital Fluid Power, Denmark (2017) pp.1-13.
- [28] Śliwiński P. POLISH Marit Res. The influence of water and mineral oil on volumetric losses in a hydraulic motor. vol. **24**, Special Issue 2017 S1 (93), (2017) pp.213–223.

