

## DEVELOPMENT OF WEARABLE IoT-BASED FRONT KICKING ANGLE MONITORING DEVICE

Nur Anida Jumadi<sup>1,2\*</sup>, Ng Chun Keat<sup>1</sup>, and Cyprian Anak Awos<sup>1</sup>

<sup>1</sup>Department of Electronic Engineering, Faculty of Electrical and Electronic Engineering, Universiti Tun Hussein Onn Malaysia, Malaysia

<sup>2</sup>Senior Researcher, Microelectronics & Nanotechnology-Shamsuddin Research Centre (MiNT-SRC), Institute of Integrated Engineering, Universiti Tun Hussein Onn Malaysia, Malaysia

\*Email: [anida@uthm.edu.my](mailto:anida@uthm.edu.my)

(Received 29 May 2019; accepted 29 July 2019; published online 1 January 2020)

*To cite this article:* Jumadi, N. A., Keat, N. C., & Awos, C. (2020). Development of wearable IoT-based front kicking angle monitoring device. *Malaysian Journal of Movement, Health & Exercise*, 9(1), 103-120. <https://doi.org/10.15282/mohe.v9i1.397>

*Link to this article:* <https://doi.org/10.15282/mohe.v9i1.397>

### Abstract

In this paper, a wearable front kicking angle monitoring device using flex sensor and Internet of Things (IoT) platform has been successfully developed and tested. The Arduino NodeMCU microcontroller processes and converts the input received from the flex sensor and transmits the real time front kicking angle and corresponding resistance data to the two main outputs; the ThingSpeak IoT platform and the LCD display for real monitoring. Thirty participants were recruited from two different backgrounds; silat athletes (n=20) and non-athlete participants (n=10). The participants were distributed into six weight categories: 50-55 kg, 55-60 kg, 60-65 kg, 65-70 kg, 70-75 kg and 75-80 kg. Based on the average angle measured from three trials, it can be observed that different participants had different averages and standard deviations for front kicking angle independently of weight category. Moreover, the background factor of the subjects involved did not greatly contribute in this research, as the participants from non-athlete background had the highest mean of front kicking angle ( $73.89 \pm 17.41^\circ$ ). This situation is probably due to a lack of standard kicking styles set for all participants at the beginning of the experiment. Nonetheless, one conclusive remark that can be derived from the findings is the front kicking angle of an individual is greatly influenced by body weight, since the (75-80 kg) weight category achieved the lowest mean angle of front kicking for both backgrounds; non-athlete ( $14.00 \pm 1.33^\circ$ ) and athlete ( $23.89 \pm 6.44^\circ$ ) subjects. In the future, additional sensors such as accelerometer can be used to predict the stability of the body for better evaluation of front kicking angle.

*Keywords:* Arduino NodeMCU, flex sensor, Internet of Things (IoT), front kicking angle, ThingSpeak

## **Introduction**

Silat has had an impact upon the civilization of Asian countries such as Indonesia, Brunei and Philippines (Shapie & Elias, 2016). It is one of the combat sports or martial arts of self-defense technique performed by Malays in Malaysia and has been recognized as one of the sport categories in sport tournament. Silat performance requires the coordination of human body part like hands and legs to perform punching and kicking. A kick technique in silat is an effort or process done by using both legs to defend and offend to gain as many scores as possible during competition (Hariono, Rahayu, & Sugiharto, 2017).

The usual kicking technique employed in silat is the front kick, which requires raising the knee and foot of the striking leg to the intended height, followed by extending the leg to the target. The front kick is commonly executed with upper body being straight and the aims of the kick will be thrust to stomach, thighs, groin and knees (Reilly, Secher, Snell, Williams, & Williams, 2005). In most situations, the ball of the foot will be used for a forward kicking while the top of the toes is used for an upward kicking to execute the actual striking to the opponent. In silat, the tactic implemented by the combat sport athlete is to control their body motion (big movement or small movement) depending on the situation since it will affect the kicking actions.

Nowadays, the usage of Internet of Things (IoT) is common due to its functionality in tracking, tracing and monitoring. For example, an IoT system has been developed to monitor patients at risk in intensive care unit by alerting the doctors or medical assistants in real-time if the system has detected any drastic changes in vital and environmental parameters or movement of the patients (Chiuchisan, Geman, & Costin, 2014).

Front kicking angle data provides the essential information to silat coaches for monitoring their athlete's performance and to construct suitable training regimen. In addition, monitoring of the data collection from the athletes will become much easier with the help of IoT technology. However, this kind of assistive tool device has not yet been explored and utilized in the combat sports, especially in silat. One possible method to measure the front kicking angle is using a flex sensor. The flex sensor can output the bending angle based on the changes in resistance. Therefore, by placing the sensor at a suitable part of the body, the front kicking angle can be measured.

Based on the research gap, several objectives have been formulated. The first objective of this research is to measure the front kicking angle when the front kicking action is performed using flex sensor, while the second objective is to develop a wireless wearable device using NodeMCU microcontroller and web database ThingSpeak. The final objective is to evaluate comparative performance among non-athlete subjects and silat athletes using a developed device. In order to achieve these objectives, the scopes of the research have been outlined based on three phases: circuit design, programming and hardware development. Circuit design phase involves the arrangement of components in the circuit. The Liquid Crystal Display (LCD) is used to display the front kicking angle of the body and corresponding resistance value. Meanwhile, Arduino IDE software is employed for coding in the programming phase. In the hardware development phase, the

flex sensor would be attached on the hip of the subjects when they perform their kicking action and the data obtained would be sent to ThingSpeak app. The next sections discuss the methods involved, results and discussion, and finally the conclusion of the study.

For the placement of flex sensor, the hip region between the pelvis and upper thigh bone (femur) was chosen. The hip joint is a ball-and-socket synovial joint located between the pelvis and the femur which connects the axial skeleton with lower part of the body (Stephen & Mariam, 2015). Figure 1 shows the illustration of hip region located between the pelvis and the upper thigh bone from the side view. According to the literature (Roas & Andersson, 1982), the hip range of motion during flexion is found to be between  $90^{\circ}$  to  $150^{\circ}$  with the means of  $120^{\circ}$ . Another study (Boone & Azen, 1979) investigating the normal range of motion of joints in male subjects shows that the average hip flexion in male is  $122.3^{\circ}$ . However, these values from both studies were recorded when the subjects were in supine and seating positions. A literature study by Roas & Andersson, (1982) measured the hip flexion when the subject in supine position and employed the measurement techniques suggested in the handbook of American Academy of Orthopaedic Surgeons (AAOS) 1965, in which a clinical goniometer was used to measure the hip flexion when the subject in sitting position as stated in Boone & Azen, (1979).

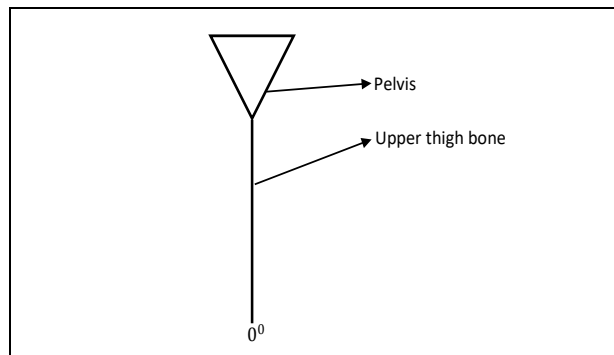

**Figure 1:** Hip region between the pelvis and the upper thigh bone from side view

The convention used to specify the joint angle for hip flexion during front kicking is shown in Figure 2. It can be seen also the flex sensor that is attached between the pelvis and the upper thigh bone. Point A is the reference position during standing, while point B is the hip flexion angle during front kicking.  $\theta$  is the angle vertex during kicking whereas  $0^{\circ}$  is the angle reference when the subject is standing still. Hence, the front kicking angle can be calculated with the attached flex sensor when subjects perform their front kicking from point A to B. Henceforth, the flex sensor will be bend to produce the front kicking angle when the sensor is placed on the hip region, since the hip flexion will cause the flex sensor to bend. This is the assumption made when designing the experiment protocol.

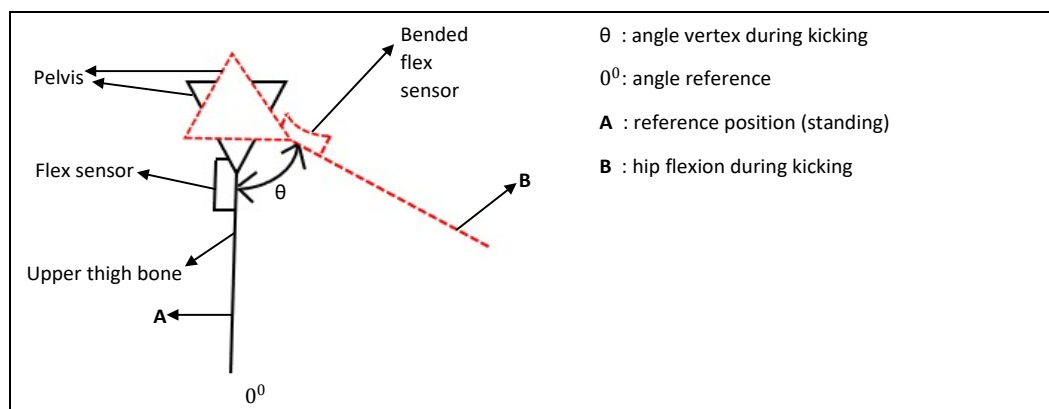

**Figure 2:** Convention used to specify the joint angle for hip flexion from side view

## Methods

### *Subjects & Experiment Protocol*

Thirty subjects were successfully recruited in this study. Twenty subjects were selected from a silat background whereas another ten subjects were non-athlete participants who did not have any experience in any combat sports. Six weight categories were selected, and the participants were distributed into their respective weight category based on their measured weight. The weight categories are 50-55kg, 55-60kg, 60-65kg, 65-70kg, 70-75kg and 75-80kg. To accommodate the experimental protocol, each participant was given a briefing and consent form. They were requested to perform three trials of kicking and were free to choose their preference kicking technique. All participants were confirmed to be able to perform front kicking without any constraints before participating in the study.

Figure 3 shows a flowchart of protocol experiment. The participants were required to attach the device on their hip and performing three trials of kicking action. The angle degree of front kicking,  $A$  ( $^{\circ}$ ) and flex sensor's resistance value,  $R$  ( $k\Omega$ ) were displayed on the liquid crystal display (LCD) for each kicking action performed. At the same time, these two parameters will also be sent to ThingSpeak website for data viewing and analysis. Meanwhile, notification via Gmail account could be set up if necessary. The monitoring of data for front kicking angle and resistance value via smartphone is possible using ThingView apps, which only require the user to download the application via Google/Tune apps store.

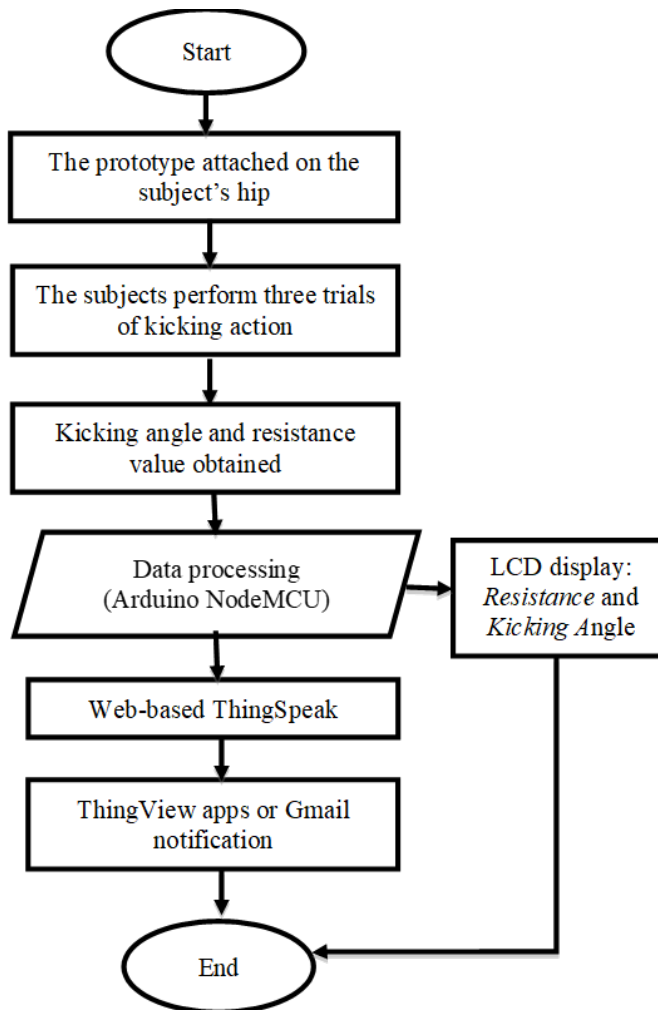

**Figure 3:** Flowchart of experiment protocol

### Components

Only three components were used in this study: a flex sensor, Arduino NodeMCU ESP8266 and liquid crystal display (LCD). The flex sensor was used to measure the amount of deflection or bending when the subjects perform the kicking action to the highest point they can achieve. Placement of flex sensor (right of left) was influenced by the subject's dominant leg on which the sensor was placed on the hip of the subjects. The flexible sensor was bent to a certain degree of angle as shown in Figure 4. Thus, the amount of bending induced by the flex sensor in the form of resistance value was converted into degree of kicking values by the Arduino NodeMCU microcontroller. These parameters were displayed on the LCD for viewing purpose as well as being sent to the ThingSpeak website for further viewing and data analysis.

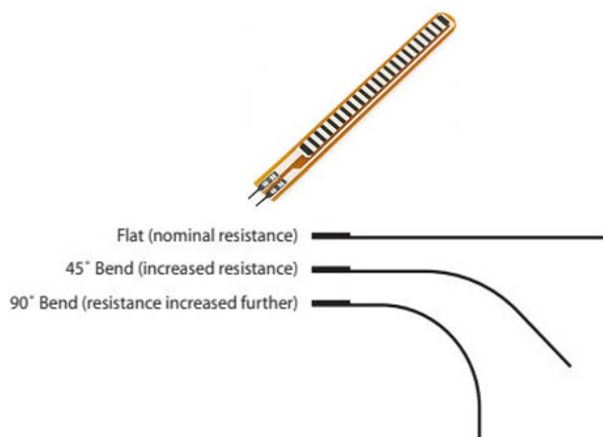

**Figure 4:** Flexible sensor and the degree of bending

The working principle of flex sensor is based on an impedance buffer, which is a single basic sided operational amplifier implemented within the sensor. The operational amplifier acts as voltage divider to reduce the error caused by the impedance source of flex sensor (Mah, Kapasi, Yeung, & Lee, 2003). Equation 1 represents the voltage divider formula, while Equation 2 shows how the resistance of flex sensor is obtained.

$$V_{OUT} = V_{IN} \left( \frac{R_2}{R_2 + R_1} \right) \quad \text{[Equation 1]}$$

$$R_1 = R_2 \left( \frac{V_{IN}}{V_{OUT}} - 1 \right) \quad \text{[Equation 2]}$$

where  $V_{OUT}$  is output voltage of flex sensor,  $V_{IN}$  is input voltage of flex sensor,  $R_1$  is flex sensor's resistance value after the bending whereas  $R_2$  is the value of series resistor (24 k $\Omega$ ). The conversion of flex sensor's resistance value into degree of front kicking angle is described in the next section.

The ESP8266 NodeMCU Lua-Wi-Fi controller board has been used in this study as it has a self-built in WiFi controller, which made connection over the Internet easier, as shown in Figure 5. Arduino IDE has been used for writing and uploading coding into Arduino board, whereas Origin software has been used to organize and display the data collected in graphical representation. Table 1 shows the connection of NodeMCU with flex sensor and LCD display panel in which the analog pin, A0 is connected to flex sensor, D1 is connected to SCL of LCD and D2 is connected to SDA of LCD for display purposes.

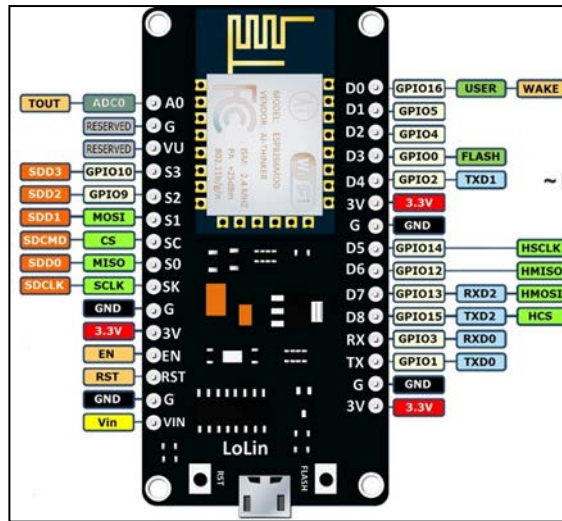

Figure 5: Arduino NodeMCU pin

Table 1: Arduino NodeMCU pin connection

Pin	Connection
A0	Analog pin connected to flex sensor
D1	Digital pin connected to SCL of LCD
D2	Digital pin connected to SDA of LCD
3V	Power supply of 3.0 V – 3.3 V
G	Ground pin

An LCD is commonly used in many hardware prototypes experiments that require simple display of data after being processed by the microcontroller. In this study, the I<sup>2</sup>C LCD will be used to display angle of kicking in degree and resistance value in ohm. The I<sup>2</sup>C LCD only requires four wires connection as shown in Figure 6 whereas Table 2 displays the LCD pin connection.

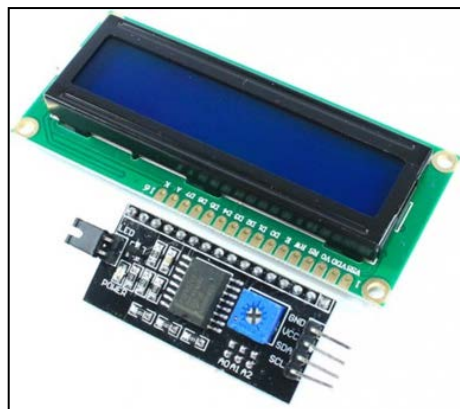
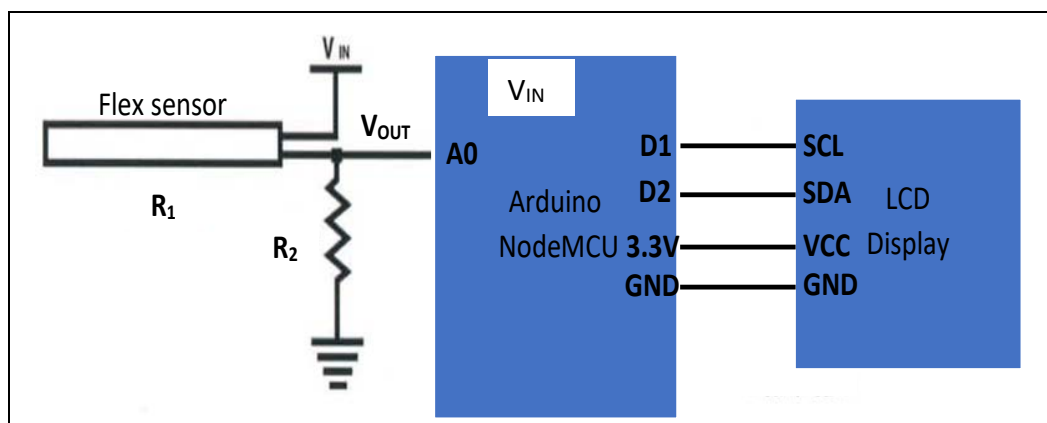

Figure 6: LCD display panel

**Table 2:** LCD pin connection

Pin	Connection
SCL	Connect to D1 of NodeMCU
SDA	Connect to D2 of NodeMCU
VCC	Connect to $V_{IN}$ of NodeMCU
GND	Ground pin

Figure 7 shows the overall connection between flex sensor, Arduino NodeMCU and LCD display. From the figure, flex sensor is connected to analog pin, A0 of Arduino NodeMCU as the input for the microcontroller. Resistance,  $R_1$  produced was processed by Arduino NodeMCU when the subjects performed the kicking action which eventually caused the flex sensor to bend. Next, LCD display acted as the output for Arduino NodeMCU when LCD was connected to the digital pin (D1 and D2), 3 V pin and the ground pin. The LCD displayed the front kicking angle and the resistance value of flex sensor after being processed by the microcontroller.



**Figure 7:** Overview circuit connection between flex sensor, NodeMCU and LCD display

### Conversion of ohmic resistances into angle degree of kicking

The flex sensor is connected to analog pin (A0) and the resistance value will be processed by NodeMCU microcontroller. Figure 8 shows the coding of conversion of resistance into angle degree. From the coding, the resistance value from the flex sensor (*analogRead(A0)*) is stored in integer *flexADC* (*int flexADC*). The *float flexV* and *float flexR* are the voltage divider formula based on Equation 1 and Equation 2 respectively. The *flexV* is the output voltage,  $V_{OUT}$  and its value must be divided by 1023 to convert it into digital value. Meanwhile, *flexR* is the resistance value from the flex sensor. The conversion of flex sensor resistance to angle degree occurs in the final row of the coding which is *float Angle*. The resistance of bending angle, *flexR* is mapped to angle of  $0^0$  to  $90^0$  to obtain the angle of kicking.



```

int flexADC = analogRead(A0);
float flexV = flexADC * 3.3 / 1023.0;
float flexR = R_DIV * (3.3 / flexV - 1.0);
float Angle = map(flexR, STRAIGHT_RESISTANCE, BEND_RESISTANCE, 0, 90.0);

```

**Figure 8:** Coding of conversion of resistance into angle degree

### *Internet of Things (IoT) platform*

The platform for IoT in this study is ThingSpeak website, as it allows the user to monitor the data collection over cloud services storage. The data obtained will automatically upload to the data server as well in mobile apps. This system continues alerting the user when the new data parameters being updated. ThingSpeak is mainly used in collecting, analyzing and act upon the setting made on the data as requested by the user (Chandana, Jilani, & Hussain, 2015). Furthermore, the user can save data to the cloud storage privately without the knowledge of others user by creating private channels. Analysis of data can be done using MatAnalysis which is an online analytical tool provided in ThingSpeak. The two types of apps usually used when using ThingSpeak are React apps and ThingHTTP apps.

The function of React apps is to match the data collected into the suitable channel where the data match the requirement set of the certain channel. A notification will be sent to the user when the data has been channeled into suitable channel. ThingHTTP is a follow-up process for React apps, which will link the channel to Gmail to show data collection within the channel. The ThingHTTP needs to establish a link with IFTTT website to process and send the feedback to Gmail. The IFTTT website requires an account to trigger Applets, which can help the user stay up to update with current changes in the system detected by ThingSpeak. IFTTT is the web service that interfaces with other web service (Ovadia, 2014), and there is an alert system which provides choices for the user to send any type of messages whether in message or webmail (Ur et al., 2016).

Figure 9 shows the ThingSpeak website and ThingView mobile apps interfaces. A power bank and LCD along with ESP8266 NodeMCU are positioned into the porch with the display of the LCD can be seen on the outside surface of the porch. A flexible sensor is attached to the holder of the porch to measure the front kicking angle of the leg.

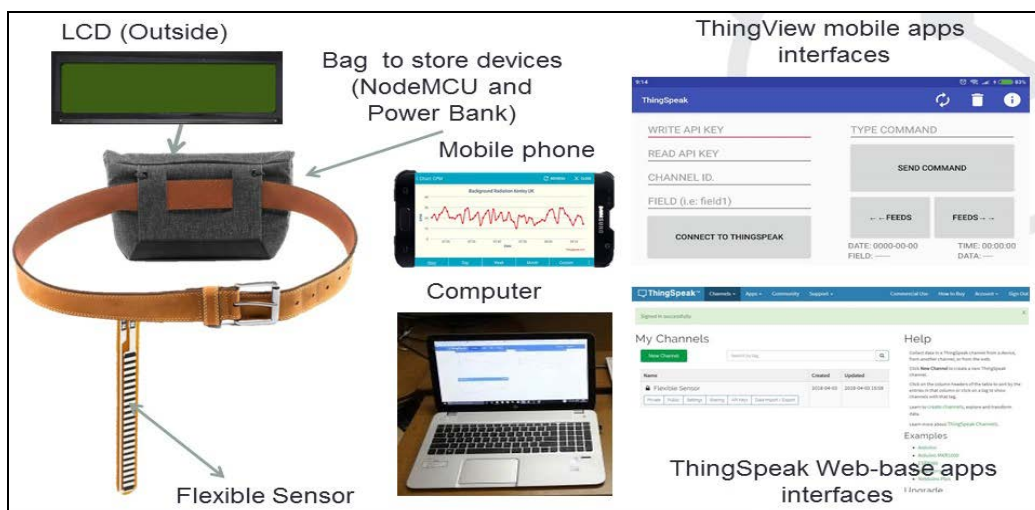

**Figure 9:** ThingSpeak website and ThingView mobile apps interface

*Final prototype design*

Figure 10 shows final circuit for the prototype design. The Arduino NodeMCU is connected to flex sensor and LCD display. The 24 kΩ resistor is used as the starting resistance for flex sensor, which means the resistance measured from each subject will be at least 24 kΩ. Figure 11 (a) and 11 (b) show top view of the casing of the prototype design; a porch used to house the final circuit of prototype. Figure 11 (b) shows the attachment of the flex sensor to the holder of the porch. The placement of the flex sensor can be changed based on the subject’s dominant leg (at left or right leg). Figure 11 (c) shows back view of the porch in which the LCD display can be seen whereas Figure 11 (d) shows the side view of the proposed device within the porch. A power bank is employed as the power source for Arduino NodeMCU and is kept within the porch. Figure 12 shows the placement of the proposed device within the porch and the flex sensor on the subject’s hip. The LCD display at the back of the porch displays the resistance value of flex sensor and the corresponding angle of front kicking.

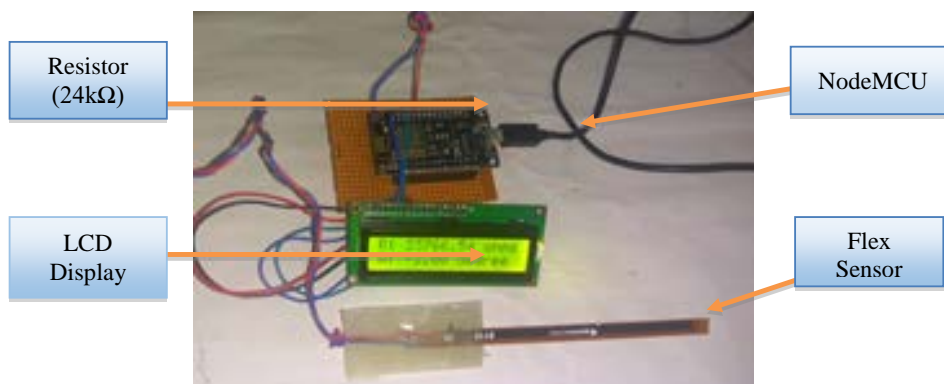

**Figure 10:** Final circuit of prototype design



(a)

(b)

(c)

(d)

**Figure 11:** (a) Top view of proposed prototype within the porch, (b) top view of porch with flex sensor attached to the porch, (c) back view of the porch with LCD display and (d) side view of the proposed device within the porch



**Figure 12:** Placement of the proposed device within the porch and the flex sensor on the subject's hip

## Results and Discussion

### *Comparative performance of front kicking angle between silat athlete and non-athlete*

Table 3 shows the degree of front kicking angle and resistance of flex sensor of twenty silat athletes. There were six participants in category (50-55kg); the highest angle of kicking was  $72.33 \pm 11.56^\circ$  and the lowest angle of kicking was  $37.33 \pm 19.78^\circ$ . In category (55-60kg), there were three participants; the highest angle of kicking achieved by one of them was  $52.33 \pm 11.78^\circ$  and the lowest angle of kicking was  $45.00 \pm 10.00^\circ$ . As for category (60-65kg), there was only one participant, who achieved angle of kicking of  $69.67 \pm 8.89^\circ$ . For category (65-70kg) and category (75-80kg), there were three participants in their respective category; the highest angle and the lowest angle of kicking in category were  $68.67 \pm 3.11^\circ$  and  $53.67 \pm 6.89^\circ$  respectively. Meanwhile, the highest angle and the lowest angle of kicking in category (75-80kg) were  $33.33 \pm 4.89^\circ$  and  $16.33 \pm 4.44^\circ$ . As for category (70-75kg), there were four participants; the highest angle of kicking was  $44.67 \pm 35.56^\circ$  and the lowest angle of kicking was  $24.00 \pm 4.67^\circ$ , respectively.

For the resistance of flex sensor, there were six participants in category (50-55 kg); the highest resistance value was  $39.46 \pm 2.39 \text{ k}\Omega$  and the lowest resistance value was  $32.25 \pm 4.15 \text{ k}\Omega$ . In category (55-60 kg), there were three participants in which the highest resistance value by one of them was  $35.37 \pm 2.50 \text{ k}\Omega$  and the lowest resistance was  $33.77 \pm 2.10 \text{ k}\Omega$ . For category (60-65 kg), there was only one participant, who achieved a resistance value of  $38.97 \pm 1.90 \text{ k}\Omega$ . For category (65-70 kg) and category (75-80 kg), there were three participants in their respective category, whereby the highest resistance value and the lowest resistance value in category (65-70 kg) were  $38.70 \pm 0.67 \text{ k}\Omega$  and  $35.60 \pm 1.50 \text{ k}\Omega$  respectively, whereas the highest resistance value and the lowest resistance value in category (75-80 kg) were  $30.98 \pm 0.80 \text{ k}\Omega$  and  $27.78 \pm 0.98 \text{ k}\Omega$ . As for category (70-75 kg), there were four participants; the highest resistance value was  $33.69 \pm 7.39 \text{ k}\Omega$  and the lowest resistance value was  $28.84 \pm 0.40 \text{ k}\Omega$ , respectively.

Thus, it can be observed that the highest angle of front kicking and resistance value of flex sensor achieved by silat athletes were  $72.33 \pm 11.56^\circ$  and  $39.46 \pm 2.39 \text{ k}\Omega$  in weight category (50-55kg) whereas the lowest angle of front kicking and resistance value of flex sensor came from category (75-80kg) which was  $16.33 \pm 4.44^\circ$  and  $27.78 \pm 0.98 \text{ k}\Omega$ . Based on the result obtained, the resistance value of flex sensor increases with increasing angle of front kicking which indicating the higher the front kicking angle, the higher the resistance value of flex sensor. Hence, it can be concluded that a smaller angle of front kicking was obtained as the weight categories increased, and the angle of front kicking was greatly affected by the increasing weight category.

**Table 3:** Degree of front kicking angle and resistance of flex sensor of silat athletes

Number of participants	Weight category (kg)	Average angle of kicking $\pm$ Standard Deviation ( $^{\circ}$ )	Resistance $\pm$ Standard Deviation (k $\Omega$ )
6	(50-55)	37.33 $\pm$ 19.78	32.25 $\pm$ 4.15
		39.67 $\pm$ 13.56	32.70 $\pm$ 2.82
		72.33 $\pm$ 11.56	39.46 $\pm$ 2.39
		61.00 $\pm$ 5.00	37.14 $\pm$ 0.79
		59.33 $\pm$ 19.78	36.81 $\pm$ 4.06
		52.33 $\pm$ 11.78	35.37 $\pm$ 2.50
3	(55-60)	47.67 $\pm$ 15.78	34.41 $\pm$ 3.28
		45.00 $\pm$ 10.00	33.77 $\pm$ 2.10
		52.33 $\pm$ 11.78	35.37 $\pm$ 2.50
1	(60-65)	69.67 $\pm$ 8.89	38.97 $\pm$ 1.90
3	(65-70)	68.67 $\pm$ 3.11	38.70 $\pm$ 0.67
		60.67 $\pm$ 2.89	37.13 $\pm$ 0.58
		53.67 $\pm$ 6.89	35.60 $\pm$ 1.50
4	(70-75)	24.00 $\pm$ 4.67	28.84 $\pm$ 0.40
		44.67 $\pm$ 35.57	33.69 $\pm$ 7.39
		34.33 $\pm$ 3.56	31.60 $\pm$ 0.78
		32.00 $\pm$ 6.67	31.05 $\pm$ 1.42
3	(75-80)	33.33 $\pm$ 4.89	30.98 $\pm$ 0.80
		22.00 $\pm$ 10.00	28.96 $\pm$ 2.06
		16.33 $\pm$ 4.44	27.78 $\pm$ 0.98

The degree of front kicking angle and resistance of flex sensor of non-athlete subjects consisting of ten participants is shown in Table 4. There was only one participant in categories (50-55kg) and (55-60kg); the angle of kicking achieved by the subjects were  $59.33 \pm 19.77^{\circ}$  and  $52.33 \pm 11.78^{\circ}$  respectively. In category (60-65kg), there were three participants. The highest angle of kicking achieved by one of them was  $85.67 \pm 32.22^{\circ}$  and the lowest angle of kicking was  $67.33 \pm 16.89^{\circ}$ . As for categories (65-70kg) and (75-80), there was only one participant in their respective category, whom achieved angle of kicking of  $53.67 \pm 6.98^{\circ}$  and  $14.00 \pm 1.33^{\circ}$ . For category (70-75kg), there were three participants; the highest angle and the lowest angle of kicking were  $35.00 \pm 4.00^{\circ}$  and  $25.00 \pm 8.00^{\circ}$ , respectively.

For the resistance value of flex sensor, there was only one participant in category (50-55 kg) and (55-60 kg), whereby the resistance value achieved by the subjects were  $36.81 \pm 4.06$  k $\Omega$  and  $35.37 \pm 2.56$  k $\Omega$  respectively. In category (60-65 kg), there were three participants. The highest resistance value achieved by one of them was  $42.37 \pm 6.74$  k $\Omega$  and the lowest resistance value was  $38.43 \pm 3.55$  k $\Omega$ . As for category (65-70kg) and (75-80), there was only one participant in their respective category, whom achieved resistance value of  $35.60 \pm 1.50$  k $\Omega$  and  $19.16 \pm 8.10$  k $\Omega$  respectively. For category (70-75 kg), there were three participants. The highest resistance value and the lowest resistance value were  $31.73 \pm 0.78$  k $\Omega$  and  $29.60 \pm 1.73$  k $\Omega$ , respectively.

Thus, it can be observed that the highest angle of front kicking and resistance value of flex sensor achieved by non-athletes were  $85.67 \pm 32.22^\circ$  and  $42.37 \pm 6.74 \text{ k}\Omega$  in weight category (60-65kg) whereas the lowest angle of front kicking and resistance value of flex sensor came from category (75-80kg) which was  $14.00 \pm 1.33^\circ$  and  $19.16 \pm 8.10 \text{ k}\Omega$ . Based on the result obtained, the higher the angle of front kicking achieved by the subjects, the higher the resistance value of flex sensor which proportional to the specification of flex sensor. The higher the amount of bending experienced by flex sensor, the higher will be the resistance value. Based on Table 3 and Table 4, the highest angle of front kicking was achieved by smaller weight categories which were silat category (50-55kg) and non-athlete category (60-65kg); the lowest angle of front kicking came from the same weight category which is category (75-80kg) for both silat athlete and non-athlete. It can be deduced that heavier weight category does influence the angle of front kicking.

**Table 4:** Degree of front kicking angle and resistance of flex sensor of non-athlete subjects

Number of participants	Weight category (kg)	Average angle of kicking $\pm$ Standard Deviation ( $^\circ$ )	Resistance $\pm$ Standard Deviation ( $\text{k}\Omega$ )
1	(50-55)	$59.33 \pm 19.77$	$36.81 \pm 4.06$
1	(55-60)	$52.33 \pm 11.78$	$35.37 \pm 2.56$
3	(60-65)	$68.67 \pm 3.11$	$38.70 \pm 0.67$
		$67.33 \pm 16.89$	$38.43 \pm 3.55$
		$85.67 \pm 32.22$	$42.37 \pm 6.74$
1	(65-70)	$53.67 \pm 6.98$	$35.60 \pm 1.50$
3	(70-75)	$27.67 \pm 20.89$	$30.15 \pm 4.42$
		$25.00 \pm 8.00$	$29.60 \pm 1.73$
		$35.00 \pm 4.00$	$31.73 \pm 0.78$
1	(75-80)	$14.00 \pm 1.33$	$19.16 \pm 8.10$

In this study, the front kicking angle was measured using flex sensor and the subject was required to do front kicking spontaneously. From the comparative analysis, the average of front kicking angle is between  $16^\circ$  to  $72^\circ$  and  $14^\circ$  to  $85^\circ$  for silat athlete and non-silat athlete subjects, respectively, even though the hip range of motion can reach up to  $120^\circ$ . *Comparison mean of degree of front kicking angle based on weight category*

For the weight categories (50-55 kg), (55-60 kg) and (60-65 kg), non-athlete subjects achieved higher angle of front kicking as compared to silat athletes. Meanwhile, silat athletes achieved higher angle of front kicking as compared to non-athlete subjects when the weight category increased to (65-70 kg), (70-75 kg) and (75-80 kg). It can be seen that non-athlete subjects achieved higher front kicking angles in the first three weight categories, whereas silat subjects achieved higher front kicking angle in the last three weight categories in the graph shown in Figure 13.

Figure 13 shows that non-athlete subjects dominated in terms of the angle of front kicking in first three weight categories as compared to silat athletes, with the highest mean of front kicking angle achieved in category (60-65kg) which was  $73.89 \pm 17.41^\circ$ . This situation is probably due to non-athlete subjects performing their front kicking action without using appropriate kicking technique as compared to silat athletes. The silat athletes perform

their front kicking action based on the techniques they have learnt in silat. This is the reason why the highest front kicking angle has been achieved by a non-athlete subject rather than a silat athlete; the highest mean angle of front kicking achieved by silat athlete in the same category was only  $69.67 \pm 8.89^\circ$ . However, one definitive deduction can be made from the findings is that heavier weight does influence the front kicking angle, as both non-athlete and silat athlete subjects achieved the lowest mean angle of front kicking in (75-80 kg) weight category, with readings recorded as  $14.00 \pm 1.33^\circ$  and  $23.89 \pm 6.44^\circ$ , respectively.

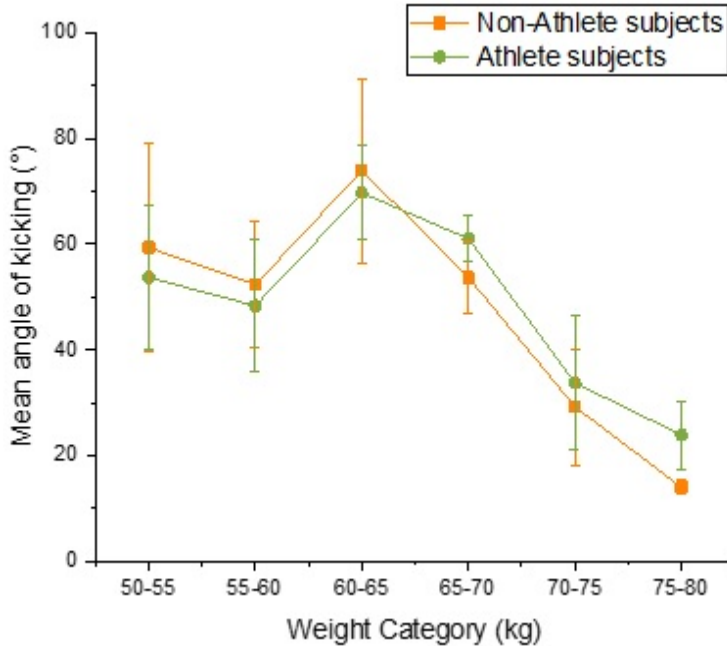

**Figure 13:** A graphical comparison of mean angle of front kicking ( $^\circ$ ) between non-athlete subjects and silat athlete

#### *ThingSpeak react channel outcome*

Meanwhile, examples of ThingSpeak display are discussed in this section. The IoT connection between the wearable device and the ThingSpeak website was successfully established. Two data, namely the the angle of front kicking and the corresponding resistance values, were recorded and displayed in real time. Figure 14 (a) shows ThingSpeak website display on angle of front kicking of non-athlete subjects whereas Figure 14 (b) shows ThingSpeak view on the resistance value of flex sensor of non-athlete subjects. On the other hand, Figure 15 (a) and Figure 15 (b) show the ThingSpeak website display of the angle of front kicking and corresponding resistance value of flex sensor of silat athlete subjects, respectively.

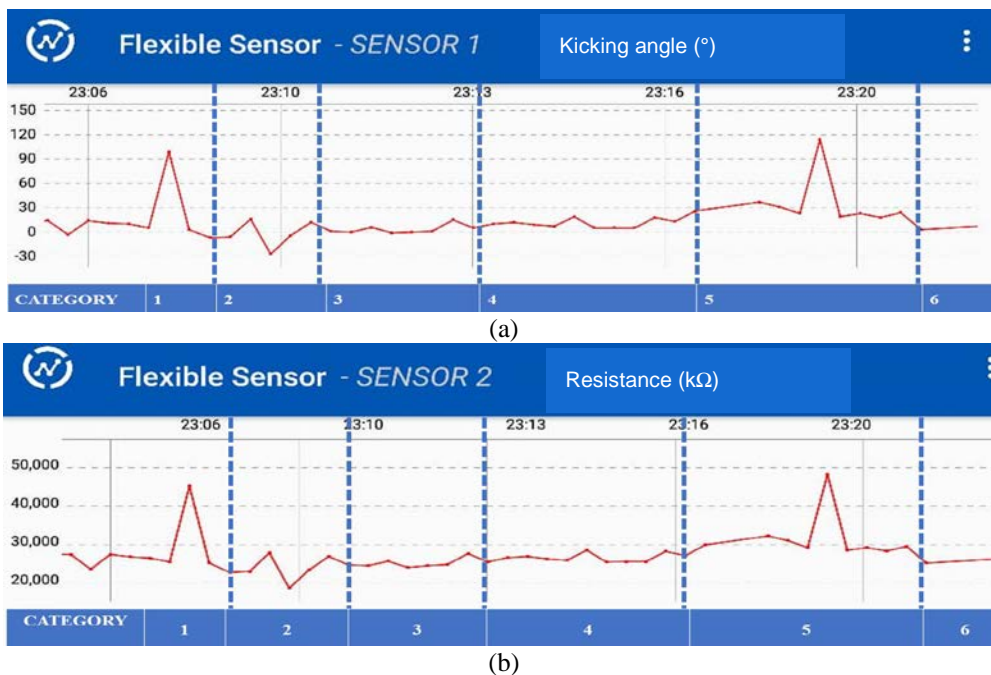

**Figure 14:** (a) ThingSpeak view on angle of front kicking of non-athlete subjects and (b) ThingSpeak view on corresponding resistance value of flex sensor of non-athlete subjects

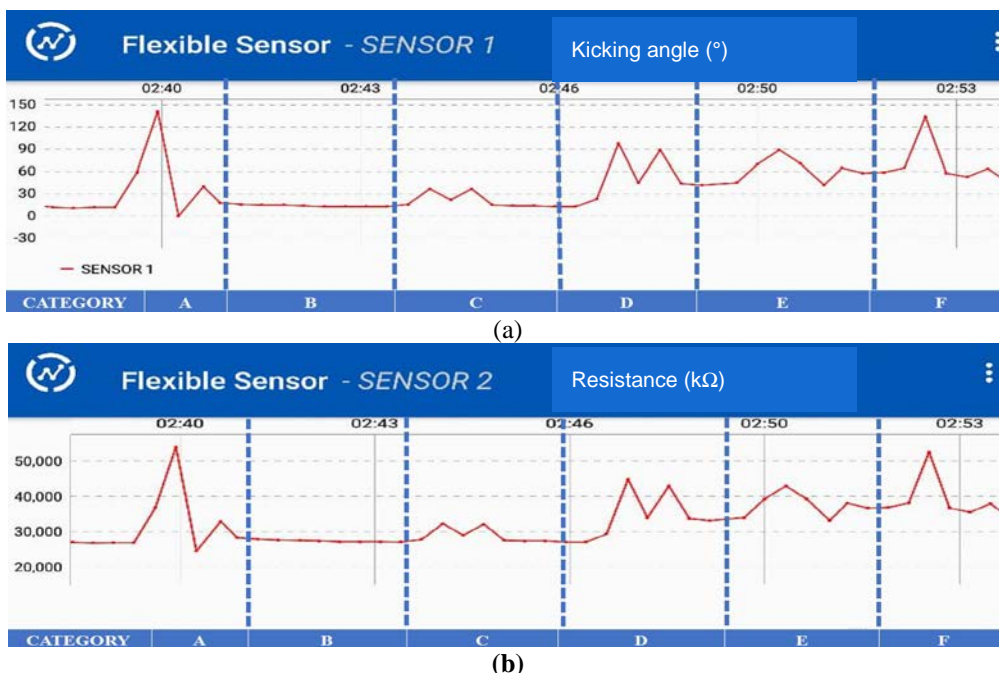

**Figure 15:** (a) ThingSpeak view on angle of front kicking of silat athlete and (b) ThingSpeak view on corresponding resistance value of flex sensor of silat athlete



## **Conclusion**

In conclusion, all objectives established for this research project have been successfully accomplished. The findings from this study reveal that the front kicking angle of an individual differed among individuals, and increasing weight will greatly influence the angle of front kicking regardless of whether the subject has a non-athlete or silat background. Although non-athlete subjects achieved the highest front kicking angle, this is due to non-athlete subjects performing their front kicking action without using appropriate kicking techniques as compared to silat athletes. Since the angle of front kicking is determined by mapping the corresponding resistance, therefore the higher the angle of front kicking, the higher the resistance value of flex sensor or vice versa. The successfully implementation of IoT technology in this project will serve as a steppingstone towards data analysis and data sharing in a convenient way as the data can be sent to the cloud storage or can be accessed by user via ThingSpeak website and ThingView apps. In future, additional sensors such as accelerometer and gyro meter may be used to predict the stability of the body for better evaluation of front kicking angle.

## **Acknowledgement**

The authors would like to express deep gratitude to the Research Management Centre (RMC), Universiti Tun Hussein Onn Malaysia (UTHM) for providing financial support via TIER1 grant (No: H226) and GPPS grant (No: H314)

## **References**

- Boone, D. C., & Azen, S. P. (1979). Normal range of motion of joints in male subjects. *Journal of Bone and Joint Surgery - Series A*, 61(5), 756–759. <https://doi.org/10.2106/00004623-197961050-00017>
- Chandana, R., Jilani, S. a K., & Hussain, S. J. (2015). Smart Surveillance System using Thing Speak and Raspberry Pi. *International Journal of Advanced Research in Computer and Communication Engineering*, 4(7), 214–218.
- Chiuchisan, I., Geman, O., & Costin, H.-N. (2014). Adopting the Internet of Things Technologies in Health Care Systems. In *2014 International Conference and Exposition on Electrical and Power Engineering (EPE 2014)* (pp. 532–535). <https://doi.org/10.1109/ICEPE.2014.6969965>
- Hariono, A., Rahayu, T., & Sugiharto. (2017). Developing a Performance Assessment of Kicks in The Competition Category of Pencak Silat Martial Arts. *The Journal of Educational Development*, 5(2), 224–237.

- Ovadia, S. (2014). Automate the Internet With “If This Then That” (IFTTT). In *Behavioral and Social Sciences Librarian* (Vol. 33, pp. 208–211). <https://doi.org/10.1080/01639269.2014.964593>
- Reilly, T., Secher, N., Snell, P., Williams, C., & Williams, D. C. (2005). *Physiology of Sports*. London: Routledge, pp512.
- Roaa, A., & Andersson, G. B. J. (1982). Normal Range of Motion of the Hip, Knee and Ankle Joints in Male Subjects, 30–40 Years of Age. *Acta Orthopaedica Scandinavica Acta Orthop. Scand*, 53(53), 205–208. <https://doi.org/10.3109/17453678208992202>
- Shapie, M. N. M., & Elias, M. S. (2016). Silat: The curriculum of Seni Silat Malaysia. *Revista de Artes Marciales Asiáticas*, 11(2s), 122–125. <https://doi.org/10.18002/rama.v11i2s.4202>
- Stephen, K. MD. & Mariam, C. DO. (2015). Hip Joint Anatomy. *Bone and Spine*, 1–14. Retrieved from <https://boneandspine.com/hip-joint-anatomy/>
- Ur, B., Pak, M., Ho, Y., Brawner, S., Lee, J., Mennicken, S., ... Littman, M. L. (2016). Trigger-Action Programming in the Wild: An Analysis of 200,000 IFTTT Recipes. In *Conference on Human Factors in Computing Systems* (pp. 3227–3231). <https://doi.org/10.1145/2858036.2858556>