

# UNIVERSITI MALAYSIA PERLIS

## DECLARATION OF THESIS

Author's full name : JUNITA BINTI MOHD NORDIN  
Date of birth : 2<sup>nd</sup> NOVEMBER 1979  
Title : DEVELOPMENT OF A NEW CODE FOR SUBCARRIER-MULTIPLEXED OPTICAL CODE DIVISION MULTIPLE ACCESS SYSTEM  
Academic Session : 2010/2011

I, hereby declare that this thesis becomes the property of Universiti Malaysia Perlis (UniMAP) and to be place at the University library. This thesis is classified as :

- CONFIDENTIAL  (Contains confidential information under the Official Secret Act 1972)  
RESTRICTED  (Contains restricted information as specified by the organization where research was done)  
OPEN ACCESS  I agree that my thesis is to be made immediately available as hard copy or on-line open access (full text)

I, the author, give permission to the Universiti Malaysia Perlis to reproduce this thesis in whole or in part of the purpose of research or academic exchange only (except during a period of ..... years, if so requested above).

Certified by

.....  
**SIGNATURE**

**791102115612**

.....  
(PASSPORT NO. / NEW IC NO.)

Date: .....

.....  
**SIGNATURE OF SUPERVISOR**

**PROFESSOR DR. SYED ALWEE ALJUNID BIN SYED JUNID**

.....  
NAME OF SUPERVISOR

Date: .....

**NOTES:** \* If there is CONFIDENTIAL or RESTRICTED, please attach with the letter from the organization with period and reasons for confidentiality or restriction.

**GRADUATE SCHOOL  
UNIVERSITY MALAYSIA PERLIS**

**PERMISSION TO USE**

In presenting this thesis in fulfillment of a post graduate degree from the Universiti Malaysia Perlis, I agree that permission for copying of this thesis in any manner, in whole or in part, for scholarly purposes may be granted by my supervisor(s) or, in their absence, by the Dean of the Graduate School. It is understood that any copying or publication or use of this thesis or parts thereof for financial gain shall not be allowed without any written permission. It is also understood that due recognition shall be given to me and to Universiti Malaysia Perlis for any scholarly use which may be made of any material from my thesis.

Request for permission to copy or to make other use of material in this thesis whole or in part should be addressed to

**Dean of Graduate School**

**Universiti Malaysia Perlis (UniMAP)**

**No. 112 & 114, Tingkat 1, Blok A, Taman Pertiwi Indah,**

**Jalan Kangar-Alor Setar,**

**Seriab, 01000 Kangar, Perlis.**

## Acknowledgement

Alhamdulillah, all praises to Allah for the opportunity to complete the thesis. There are many to whom I would like to say thank you to. First and foremost, my highest appreciation to my supervisor, Professor Dr. Syed Alwee AlJunid Syed Junid, who willingly accepted me as a student without doubt, believes in me on finishing this study, with full support and encouragement. To my co-supervisors, Prof Dr R Badlishah Ahmad and Associate Prof. Dr Naufal Saad, thank you for the words of guidance and motivations. My heartiest thank you to both of my beloved parents, who continuously pray for my success and unconditionally supported me along the way, taking care of my children when I have no one else to turn to. Dad, I did this for you. I would also like to acknowledge my siblings, too, for their moral support and always seeing the positive side in me. My endless thanks and deepest appreciations to the one who has walked with me along the way, whom understands my situations and pick me up every time I feel down, no other than my patient and caring husband, Rosemizi Abd Rahim. I could have never completed this journey without his unconditional love and support. To my children, thank you for all the love and joy that you bring. I promise to make it up to all the good times we missed. My sincere appreciations for my colleagues, Dr Ir Anuar Mat Safar, Dr Amir Razif, Dr Hilal, Dr Thanaa Hussain, Rashidi Che Beson and Abd Rahman Kram for sharing fruitful thoughts and opinions. Last but not least, I would like to acknowledge the Malaysian Ministry of Higher Education and Universiti Malaysia Perlis, for supporting my studies, financially.

*Junita Mohd Nordin*

## TABLE OF CONTENTS

	<b>PAGE</b>
<b>THESIS DECLARATION</b>	i
<b>PERMISSION TO USE</b>	ii
<b>ACKNOWLEDGEMENT</b>	iii
<b>TABLE OF CONTENTS</b>	iv
<b>LIST OF TABLES</b>	ix
<b>LIST OF FIGURES</b>	x
<b>LIST OF ABBREVIATIONS</b>	xiv
<b>ABSTRAK (B.MELAYU)</b>	xvi
<b>ABSTRACT (ENGLISH)</b>	xvii
<b>CHAPTER 1 INTRODUCTION</b>	
1.1 Project Background and Motivations	1
1.2 Research Objectives	7
1.3 Scope Of Work	8
1.4 Contribution of This Research	8
1.5 Thesis Outlines	9
<b>CHAPTER 2 LITERATURE REVIEWS AND BACKGROUND STUDIES</b>	
2.1 Introduction	11
2.2 Multiple Access Schemes	11
2.2.1 Optical Time Division Multiple Access (OTDMA)	12
2.2.2 Wavelength Division Multiple Access (WDMA)	14
2.2.3 Optical Code Division Multiple Access (OCDMA)	15

2.3	Classification of OCDMA Systems	19
2.3.1	Coherent OCDMA Systems	20
2.3.2	Incoherent OCDMA Systems	21
2.3.2.1	Temporal Encoding OCDMA	22
2.3.2.2	Spectral Amplitude Coding (SAC)	24
2.4	Incoherent SAC OCDMA Code Families	25
2.4.1	Modified Quadratic Congruence (MQC)	26
2.4.2	Modified Frequency Hopping (MFH)	28
2.4.3	Double Weight (DW)	31
2.4.4	Modified Double Weight (MDW)	32
2.4.5	Enhanced Double Weight (EDW)	34
2.4.6	Zero Cross Correlation (ZCC)	35
2.4.7	Random Diagonal (RD)	37
2.5	Subcarrier Multiplexing	42
2.6	Summary	44

### **CHAPTER 3 DEVELOPMENT OF RECURSIVE COMBINATORIAL CODE**

3.1	Introduction	46
3.2	Research Methodology	46
3.3	Design Performance Parameters	48
3.4	Simulation Analysis	49
3.5	Code Performance Analysis Methodology	50
3.6	Recursive Combinatorial (RC) Code	52
3.6.1	Code Construction	52

3.6.2	Code Design Algorithm for specific user	62
3.6.3	Flexibility of RC code in OCDMA System Network	63
3.7	Encoding and Decoding Design of RC Code	68
3.8	Recursive Combinatorial (RC) Code Properties	73
3.9	Codes Comparison	74
3.10	Summary	79

## **CHAPTER 4 NOISE ANALYSIS AND DETECTION TECHNIQUE IN OCDMA SYSTEM**

4.1	Introduction	80
4.2	Multiple Access Interference (MAI)	80
4.3	Noise Affecting the Receiver	81
4.3.1	Thermal Noise	82
4.3.2	Shot Noise	83
4.3.3	Phase Intensity Induced Noise (PIIN)	84
4.4	Detection Techniques in OCDMA System	85
4.4.1	AND- Subtraction Technique	86
4.4.1.1	RC Code using AND Subtraction Technique	87
4.4.2	Direct Detection Technique	99
4.4.2.1	RC Code using Direct Detection Technique	99
4.5	Performance Analysis Comparison between AND Subtraction Technique and Direct Detection Technique	103
4.5.1	Calculated Results	103
4.5.1.1	Cardinality	103

4.5.1.2	Received Power	105
4.5.1.3	Bit Rates	106
4.5.2	Simulation Results	107
4.5.2.1	Effect of Bit Rates on System Performance	109
4.5.2.2	Effect of Transmission Distance on System Performance	110
4.6	Summary	110

## **CHAPTER 5 PERFORMANCE ANALYSIS OF RECURSIVE COMBINATORIAL CODE**

5.1	Introduction	112
5.2	RC code Theoretical Analysis	112
5.2.1	System Performance based on cardinality taken into account all dominated noise	114
5.2.2	System Performance with respect to Effective power ( $P_{sr}$ )	116
5.2.3	Effect of Received Power ( $P_{sr}$ ) on Shot Noise	117
5.2.4	Effect of Code length and Code weight on Shot Noise	119
5.2.5	Effect of Code Length and Code Weight on System Performance	119
5.2.6	Effect of using PIN and APD Photo detector on System Performance	126
5.3	Simulation Results	128
5.3.1	Effect of PIN and Avalanche Photo detector on System Performance	128
5.3.2	Effect of different data formatting scheme	130
5.3.3	Effect of distance on system performance	131

5.4	Comparison of Theoretical and Simulation Results	132
5.5	Summary	134

**CHAPTER 6 PERFORMANCE OF SUBCARRIER- MULTIPLEXED (SCM)-  
OCDMA SYSTEM USING RECURSIVE COMBINATORIAL CODE**

6.1	Introduction	136
6.2	Subcarrier-Multiplexed OCDMA System Architecture	136
6.3	Theoretical Analysis of SCM-OCDMA based on RC code	138
6.4	Performance of SCM OCDMA based on RC code	144
6.5	Simulation Analysis of the SCM OCDMA System based on RC code	153
6.6	Comparison of Theoretical and Simulation Results	158
6.7	Summary	161

**CHAPTER 7 CONCLUSION AND FUTURE WORK**

7.1	Conclusion	159
7.2	Recommendation for Future Work	161

<b>REFERENCES</b>	166
-------------------	-----

<b>APPENDIX A</b>	177
-------------------	-----

<b>PUBLICATIONS</b>	182
---------------------	-----



## LIST OF TABLES

NO.		PAGE
1.1	Comparison of Common Optical Multiple Access Schemes	3
2.1	Example of MFH code	30
2.2	MDW code for K=6 and W=4	33
2.3	An Example of the RD Code Sequence (W=4; K=3)	41
3.1	Relation between number of users, weight and code length	60
3.2	A list of RC code sequences for K=6 and W=4.	61
3.3	EDW Code with W=3, K=3	64
3.4	EDW Code with W=5, K=5	64
3.5	MDW Code with W=4, K=3	65
3.6	MDW Code with W=6, K=4	65
3.7	Mapping of RC code and wavelengths	69
3.8	Code Comparison in term of code length for same number of subscribers (K=30)	74
3.9	Comparison of various SAC OCDMA code's characteristic	76
3.10	Some SAC OCDMA codes and their general properties	78
4.1	Symbols and Parameters Used in Equation (4.4)	88
4.2	Process of AND Detection Technique between Different Code Sequences when $m \neq n$ ( $C_m \neq C_n$ )	91
4.3	Typical Parameters used in the calculation	104
5.1	Typical Parameter used in the Theoretical Analysis	113
5.2	SNR properties for different codes	116
6.1	The parameters used for BER calculation	143

## LIST OF FIGURES

<b>NO.</b>		<b>PAGE</b>
1.1	SCM/WDM basic architecture	7
2.1	Three types of multiple access schemes	12
2.2	Time division multiple access (TDMA) network	13
2.3	Wavelength division multiple access (WDMA) network	14
2.4	Optical Signal Waveforms Encoded of OCDMA System	16
2.5	A basic concept of OCDMA System	17
2.6	Different categories to classify OCDMA System	19
2.7	Block Diagram of an Incoherent OCDMA System Experimental Setup	23
2.8	Block Diagram of SAC-OCDMA System	24
2.9	Generation of $y_{0,0}(k)$ and $s_{0,0}(k)$ for $p=5$ , $d=1$ and $b=2$	28
2.10	Basic concept of subcarrier multiplexing	43
2.11	Illustration of a subcarrier multiplexing spectrum	43
3.1	Flow chart of the RC code construction	59
3.2	Relationship between code length, L with number of users, K and code weight, W	60
3.3	Encoder design for RC code weight three and three users	70
3.4	Spectra of RC code (a) first channel, (b) second channel and (c) third channel	72
3.5	Decoder configuration of RC code with weight three and three users	72
4.1	SAC-OCDMA System Architecture using AND Detection Technique	87
4.2	PSD of the Received Signal $r(v)$	92
4.3	System setup for Direct Detection Technique	100
4.4	BER versus Number of Simultaneous Users When $P_{sr} = -10$ dBm (W=3, 622Mbps)	105
4.5	BER versus $P_{sr}$ when number of simultaneous users is 20 (622Mbps)	106

4.6	BER versus bit rates when number of users, $K=15$ and $K=30$	107
4.7	Simulation setup for RC code using AND subtraction technique	108
4.8	Simulation Setup for RC code using Direct Detection technique	108
4.9	System Performance with respect to bit rates	109
4.10	BER performance versus fiber length (km) at 622Mbps	110
5.1	Variation of BER with respect to number of users at 622Mbps for different codes	114
5.2	Signal-to Noise ratio of different codes versus number of users (622Mbps)	115
5.3	Comparison of effective power transmitted for various codes at 622Mbps	117
5.4	Comparison of shot noise with respect to effective transmitted power ( $P_{sr}$ ) for different codes at 622Mbps	118
5.5	Shot Noise variations with respect to code length for different code weight	119
5.6	BER performance with respect to number of users (622 Mbps)	120
5.7	BER versus code length with different code weight ( $P_{sr} = -10\text{dBm}$ ; 622Mbps)	121
5.8	Illustration of power spectrum with code length, $N = 21$ and weight, $W=4$ . Different colour represents different code sequence for each user	122
5.9	Illustration of power spectrum with code length, $N = 21$ and weight, $W=5$ . Different colour represents different code sequence for each user	122
5.10	Illustration of power spectrum with code length, $N = 21$ and weight, $W=6$ . Different colour represents different code sequence for each user	122
5.11	BER with respect to effective power for different number of users ( $K=10, 20, 30$ and $40$ ; 155Mbps)	124
5.12	BER versus effective received power with various weights (622Mbps)	125
5.13	BER with respect to bit rates for different number of simultaneous users ( $W = 3$ ; $P_{sr} = -10 \text{ dBm}$ ; 622Mbps).	126
5.14	BER performance over simultaneous number of users of RC code using APD and PIN compared to other codes (622Mbps)	127
5.15	Effect of APD on BER Performance over effective power, $P_{sr}$ (dBm)	128

5.16	BER performance with respect to number of users using PIN and APD photo detector (622 Mbps)	129
5.17	PIN and APD performance comparison with respect to distances	130
5.18	RC code system performance using RZ and NRZ modulation versus number of users ( $W = 3$ , 622Mbps)	131
5.19	BER performances with variation of transmission distances for different number of users ( $W=3$ , 622Mbps)	132
5.20	Comparison of theoretical and simulation result of RC code with respect to number of simultaneous users ( $W=3$ , $P_{sr} = -10dBm$ ; 622Mbps)	133
5.21	Comparison of theoretical and simulation result of RC code with various bit rates ( $K = 20$ ; $W = 3$ ; $P_{sr} = -10dBm$ )	133
6.1	SCM-OCDMA System Configuration based on RC code	137
6.2	BER Performance with respect to number of subcarriers using different codes (155Mbps)	144
6.3	System performance versus number of subcarrier channels for different bit rates	145
6.4	System performance curves for different value of OCDMA codes ( $K= 3, 6 \& 8$ ; 155Mbps)	146
6.5	System performance with respect to effective transmitted power, $P_{sr}$ for conventional OCDMA system (bit rates =155 Mbps)	147
6.6	System performance with respect to the effective transmitted power, $P_{sr}$ for different number of subcarrier channels ( $K =3, W=3, 155Mbps$ )	148
6.7	BER as a function of number of simultaneous users for different code weight ( $K =5$ ; 155Mbps)	149
6.8	BER versus effective power for different bit rates ( $K=2, W=3$ , subcarrier channels ( $sc$ ) = 4)	150
6.9	Performance Comparison of SCM OCDMA with APD and PIN Photo detectors	150
6.10	System Performance versus APD Gain for different code weight with subcarrier channels = 3 and 6.	152
6.11	Effect of APD on signal power and noise power of SCM-OCDMA system	153

6.12	Example of six SCM channels at the transmitter	154
6.13	BER Performance over distances (km) with different number of subcarrier channels (bit rates = 155Mbps)	155
6.14	Eye Diagram of SCM OCDMA with (a) 6 subcarriers and (b) 8 subcarriers at 30km	156
6.15	Plots on the effect on Input Power on to the system Performance with respect to transmission distances (bit rates = 155 Mbps)	156
6.16	Eye Diagram of SCM OCDMA at 155Mbps; $P_{sr} = -10\text{dBm}$	157
6.17	Eye Diagram of SCM OCDMA at 622 Mbps; $P_{sr} = -10\text{ dBm}$	158
6.18	Theoretical and Simulation Comparison for bit rates =155 Mbps and 622 Mbps ( $K=2$ , $W=3$ , subcarrier channels (sc) = 4)	159
6.19	Theoretical and Simulation Curves for System Performance with respect to number of subcarriers (bit rates = 155Mbps)	160
6.20	Theoretical and Simulation Comparison for BER versus effective power, $P_{sr}$ (bit rates = 155 Mbps)	161

## LIST OF ABBREVIATIONS

APD	Avalanche Photo Detector
BER	Bit Error Rate
CDMA	Code Division Multiple Access
CW	Continuous Wave
DCS	Dynamic Cyclic Shift
EDFA	Erbium Doped Fiber Amplifier
EDW	Enhanced Double Weight
FBG	Fiber Bragg Grating
FWM	Four Wave Mixing
Gb/s	Gigabit per second
GF	Galois Field
LAN	Local Area Network
LED	Light Emitting Diode
MAI	Multiple Access Interference
Mb/s	Mega bit per second
MDW	Modified Double Weight
MFH	Modified Frequency Hopping
MQC	Modified Quadratic Congruence
NDSF	Non Dispersion Shift Fiber
NRZ	Non Return to Zero
OOC	Optical Orthogonal Code
OCDMA	Optical Code Division Multiple Access
OOK	On-Off Keying

PIIN	Phase Induced Intensity Noise
PIN	Positive Intrinsic Negative
PMD	Polarization Mode Dispersion
PRBS	Pseudo Random Binary Sequence
PSD	Power Spectral Density
RD	Random Diagonal
RF	Radio Frequency
ROF	Radio Over Fiber
RZ	Return to Zero
SAC	Spectral Amplitude Coding
SCM	Subcarrier Multiplexing
SLD	Super Luminescent Diode
SMF	Single Mode Fiber
SNR	Signal to Noise-Ratio
SPC	Spectral Phase Coding
SPM	Self Phase Modulation
TDMA	Time Division Multiple Access
WDM	Wavelength Division Multiplexing
WDMA	Wavelength Division Multiple Access
ZCC	Zero Cross Correlation

# Pembangunan Kod Baru untuk Sistem Subpembawa Multipleks – Pembahagian Kod Berbilang Capaian Optik

## ABSTRAK

Pertumbuhan penggunaan aplikasi- aplikasi internet dan multi media yang mendambakan jalur lebar telah membawa kepada penyelidikan pembangunan yang besar dalam mengoptimalkan kapasiti jalur lebar dalam perhubungan optik, terutamanya dalam Pembahagian Kod Optik Berbilang Capaian (OCDMA). Di dalam kerja ini, satu kod baru di dalam kumpulan pengkodan amplitud spektrum OCDMA telah dibangunkan sebagai satu usaha untuk menangani keterbatasan yang dihadapi oleh kod- kod lain yang sedia ada di dalam kelas yang sama. Kerja ini juga menyumbang kepada pembangunan model matematik subpembawa hibrid sistem multipleks OCDMA berdasarkan kod baru dan penilaian prestasi sistem ini. Gabungan SCM dan skim OCDMA boleh dianggap sebagai bidang penyelidikan baru yang masih di peringkat awal, kerana kerja-kerja yang sering dijalankan dalam SCM adalah memberi keistimewaan untuk gabungan dengan bahagian skim pemultipleksan gelombang (WDM). Gabungan ini menunjukkan peningkatan dalam penggunaan jalur lebar komunikasi optik. Secara terperinci, tesis ini bermula dengan pembinaan kod yang jelas, dinamakan sebagai kod kombinasi pengulangan (RC) yang direka untuk mempunyai silangan sekaitan yang minimum iaitu satu, dengan fleksibiliti untuk memilih parameter kod seperti pemberat kod dan bilangan jujukan kod, bersama panjang kod yang minima. Pembangunan kod yang ringkas adalah berdasarkan kaedah kombinasi matriks untuk mengekalkan hanya satu silangan sekaitan di antara jujukan kod bagi mengurangkan gangguan berbilang capaian (MAI). Terbitan matematik telah dijanakan untuk teori prestasi kod bagi menganalisa pencapaiannya di dalam sistem OCDMA. Simulasi dijalankan bagi menilai dan mengoptimalkan parameter-parameter untuk prestasi terbaik di dalam sistem. Kajian ini memberi tumpuan kepada kesan jarak, kadar bit, format modulasi data dan kuasa input terhadap prestasi sistem. Validasi keputusan teori dengan keluaran simulasi juga dijalankan. Dari analisa prestasi, kod ini mempamerkan prestasi yang lebih baik berbanding kod-kod lain di dalam kelas yang sama. Dari segi kardinaliti, kod ini mampu menampung sebanyak 105 pengguna serentak dengan kebenaran kadar ralat  $10^{-9}$ . Dapat ditunjukkan bahawa menggunakan kod RC, SCM OCDMA boleh menampung sehingga 28 saluran subpembawa untuk BER lebih baik daripada  $10^{-9}$ . Sebaliknya, kod MDW, hanya boleh menampung sehingga 20 saluran subpembawa. Model simulasi juga dibangunkan untuk sistem SCM OCDMA, di mana beberapa perbandingan dibuat bagi prestasi sistem tersebut. Kesimpulannya, sumbangan besar tesis ini terletak dalam pembangunan kod baru yang mempamerkan pembinaan kod yang sangat mudah dan sesuai bagi memudahkan pelaksanaan dalam rangkaian praktikal. Dengan menggunakan kod ini, menambah pengguna baru dalam rangkaian tidak memerlukan pengubahsuaian rangkaian yang sedia ada; nod boleh ditambah pada panjang gelombang yang ada seterusnya di sepanjang jalur lebar diduduki. Pada masa yang sama, menambah berat kod tidak akan mengubah apa-apa parameter lain. Dalam erti kata lain, reka bentuk kod ini mengekalkan keperibadian setiap parameter kod, oleh itu menjadikannya kod yang lebih fleksibel berbanding dengan yang lain. Selain daripada itu, model teori dan simulasi yang diperolehi untuk sistem hibrid subpembawa multipleks OCDMA berdasarkan kod RC telah merealisasikan pendekatan yang berpotensi dalam meningkatkan kecekapan penggunaan lebar jalur komunikasi optik.



# Development of New Code for Subcarrier Multiplexed – Optical Code Division Multiple Access System

## ABSTRACT

The growing utilization of bandwidth hungry applications of the internet and multimedia applications has led to tremendous research development in optimizing the bandwidth capacity in optical communication, particularly in Optical Code Division Multiple Access (OCDMA). In this work, a new code in the family of Spectral Amplitude Coding (SAC) OCDMA has been developed in an attempt to overcome the limitations faced by other existing codes of the same class. This work also contributes to the development of mathematical model of hybrid subcarrier multiplexed OCDMA system based on the new code and its performance evaluations. The combination of Subcarrier Multiplexing (SCM) and OCDMA scheme can be regarded as a new research area which is still in its infancy, since most work on SCM gives privilege to the combination with Wavelength division multiplexing (WDM) scheme. This combination demonstrates an improvement in bandwidth utilization of optical communication. In particular, this thesis begins with an explicit construction of the code, namely the Recursive Combinatorial (RC) code that is designed to have a minimum cross correlation of one, with the flexibility of choosing the code's parameter, such as the code weight and number of code sequences, with minimum code length. The simple code development are based on the matrix combinatorial method to maintain the cross correlation of one between the code sequences, that reduces the Multiple Access Interference (MAI). The mathematical derivation of this code's performance is then generated to analyze its performance in the OCDMA system. Simulations are carried out to evaluate and optimize the parameters for best performance in the system. The study focuses on the effect of distance, bit rate, data modulation format and input power on the systems performance. Validations of theoretical results by simulations are also conducted. It is shown from the performance analysis that this codes exhibits better performance compared to other codes in the same class. It is shown in term of cardinality; this code could accommodate up to 105 users simultaneously at a permissible bit error rate of  $10^{-9}$ . In the hybrid SCM OCDMA using RC code, this system could accommodate up to 28 subcarrier channels for BER better than  $10^{-9}$ . On the other hand, the MDW code, as compared, can only accommodate up to 20 subcarrier channels. A simulation model is also developed for the SCM OCDMA system, where some comparisons are being made on its performances. In short, the significant contribution of this thesis lies in the development of a new code exhibiting a very simple code construction, which is suitable for the ease of implementation in a practical network. Adding new users in the network using this code does not require modifying the existing network; nodes can be added at the next available wavelength along the bandwidth occupied. At the same time, adding up the code weight will not change any other parameters. In other words, this code design retains the individuality of each code parameter, hence making it a more flexible code compared to others. Apart from that, the theoretical and simulation model derived for a hybrid system of subcarrier multiplexed OCDMA based on RC code has realized a potential approach in improving the bandwidth utilization efficiency of optical communication.

# CHAPTER 1

## INTRODUCTION

### 1.1 Project Background and Motivations

Recent years have seen the rapid growth of bandwidth hungry broadband access network for applications such as internet, High Definition TV (HDTV), triple play services, multimedia applications and gaming, which keeps the network, and service providers busy finding ways of connecting the network up to the last mile solutions. Conventional communication links such in wireless communication and satellite communications are already left with the bandwidth constraints to provide high speed data for various new services over the communication network.

Optical communications came along taking the attention more than two decades ago because of the huge amount of bandwidth it offers. Optical fiber has then been widely deployed in long haul networks which carry a huge amount of information over long distances. However, to provide high speed data to the increasing broadband populations, the research and development in the optical communications are focused on the techniques for providing bandwidth efficient multiple access formats and protocols (Fouli & Maier, 2007, Kwong, 2005). In the optical communication, there are three major multiple accesses, which are the Optical Code Division Multiple Access (OCDMA), Wavelength Division Multiple Access (WDMA) and Time Division Multiple Access (TDMA). Even their combination is proposed and improved.

In TDMA, the concept is to increase the bit rate carried by a single optical wavelength, where high bit rates are achieved by using very short pulses. This technique, however, are sensitive to dispersion (due to the wide bandwidth nature of the

signal) and nonlinearities. As technology grew, WDMA seems the best solution. WDMA principle makes better use of the optical fiber bandwidth by allocating each user a single wavelength. One advantage of WDMA over TDMA is that it usually uses lower bit rates and optical power in each channel, yet achieving higher network capacity. However, WDMA is also limited by some factors such as limited wavelengths when it comes to large number of users. Hence, unfortunately, it is obvious that both multiple access present significant drawbacks in local area systems requiring large number of users (P. Prucnal, Santoro, & Ting, 1986; P. R. Prucnal, 2006). Also, the maximum transmission capacity for TDMA and WDMA depends on the total number of time slots and wavelength channels respectively (Yin & Richardson, 2007).

The most popular multiple access technique nowadays is the OCDMA (Fadhil, H.A., 2012; Eltaif, Shalaby, Shaari, & Hamarsheh, 2009; Lin, Huang, & Yang, 2007; Weng & Wu, 2001) due to its advantages over WDMA and TDMA. In OCDMA, users are distinguished by assigning them an unique optical code. Hence each data bits are signed by this optical code to differentiate it from other users. This coding scheme allows users to share the same wavelength with asynchronous operation. In addition, it offers resilience against eavesdropping because of the coding (Spuensens, 2008). In term of scalability, OCDMA can accommodate higher number of subscribers compare to TDMA or WDMA. Multi rate OCDMA scheme allows the low and high bit rate channels transmitting on the same OCDMA network. Hence, the current demand of variable bit rates operation can thus be fulfilled. The OCDMA also does not require centralized network control. A self-routing is coded with assigned users where bandwidth is effectively utilized. Due to this, the complicated routine algorithm such in other multiple access schemes is reduced. In term of information security, the information data are protected in both the code level and transmission medium level in

OCDMA. It is free from packet collisions, resulting in very low latencies. Eavesdroppers could not intercept the information data without knowledge of which code is being used to send the particular data to a particular user. Unlike TDMA, an asynchronous access protocol permits OCDMA to be randomly and simultaneously accessed without timing synchronization. A dynamic bandwidth allocation and soft capacity on demand makes it flexible wavelength control, with adding and removing subscribers (Dexter, et al., 2009; Yin, Liang, Ma, & Qin, 2009). The advantages and disadvantages of these three schemes are summarized in Table 1.1.

Table 1.1: Comparison of Common Optical Multiple Access Schemes (Yin & Richardson, 2007).

Multiple Access Schemes	Advantages	Disadvantages
1. TDMA	<ul style="list-style-type: none"> <li>a. Dedicated channels provided</li> <li>b. High throughput</li> <li>c. Deterministic access</li> </ul>	<ul style="list-style-type: none"> <li>a. Accurate synchronization needed.</li> <li>b. Bandwidth wasted</li> <li>c. Channel not efficiently used</li> <li>d. Deterioration of performance as number of users increases.</li> </ul>
2. WDMA	<ul style="list-style-type: none"> <li>a. Dedicated channels provided</li> <li>b. Simultaneous users allowed</li> <li>c. High bandwidth efficiency</li> <li>d. Simultaneous users allowed</li> </ul>	<ul style="list-style-type: none"> <li>a. Channel crosstalk</li> <li>b. Channel idle most of the time</li> <li>c. Non-linear effects</li> </ul>
3. OCDMA	<ul style="list-style-type: none"> <li>a. Simultaneous users allowed</li> <li>b. Asynchronous access</li> <li>c. No delay or scheduling</li> <li>d. High bandwidth efficiency</li> <li>e. Efficient for bursty traffic.</li> <li>f. Dedicated channels provided</li> </ul>	<ul style="list-style-type: none"> <li>a. Performance degrades with increase the number of simultaneous users.</li> </ul>

OCDMA is basically distinguished by the coding domain, which is time, wavelength or both. They are also differentiated by the coding principle, which is either coding is in optical intensity or in the optical field. In time domain implementations, the coding rate has to be higher than the data rate, thus requiring a high speed data rate even to transmit data at a moderate rate. Subsequently, high speed electro-optics equipment which is generally expensive, are required, thus leaving the time domain implementation not to be very popular for access networks. Wavelength domains are split into two, which are the coherent and incoherent implementations. The coherent wavelength domain implementation applies phase shifts on spectral components of an optical pulse. These systems require accurate phase control which makes them expensive (Spuensens, 2008).

In the incoherent wavelength domain implementation several frequency bins from a broadband source are dedicated to the users. Incoherent OCDMA systems are known not just for their cost-effective implementation, but also for their sensitivity to multiple access interference (MAI), that results when large number of simultaneous users transmit at the same time and on the same common channel (Aljunid, Ismail, et. al, 2004). In addition, there are other noises arising from the physical effect of the system design itself, such as Phase Induced Intensity Noise (PIIN), thermal noise, and shot noise (Fadhil, H.A. et. al, 2009a; Shin-Pin & Jingshown, 2010). Here, the overlapping spectra from diverse users creates cross correlation function that relates the PIIN with the MAI (Aljunid, Ismail, et al., 2004; Fadhil, H.A.,et. al 2012). These drawbacks leave a challenge to OCDMA's researchers to find ways on reducing the MAI and also the PIIN noise.

Among all the OCDMA approaches the Spectral Amplitude Coding OCDMA (SAC-OCDMA) technique attracts much attention due to its capability to remove the

MAI completely by spectral coding (Kavehrad & Zaccarin, 1995). Theoretically, the MAI can be removed when using code with fixed in phase cross-correlation (Shin-Pin & Jingshown, 2010). Hence, an intelligent design of code sequence is necessary to eliminate the effect of MAI in OCDMA systems (Stok & Sargent, 2000). It is desirable to design a code that exhibits a low cross correlation characteristic between its code sequences, which in turn minimized the overlapping bits between the codes.

Although some few codes have been developed to restrain the PIIN noise or to remove the MAI for SAC OCDMA, these codes still suffer from some limitations. They suffer from high cross correlation values, e.g. Hadamard (Li & Chan, 1997) and Random Diagonal (H.A. Fadhil, Aljunid & Ahmad, 2009c), exist for only certain parameters, for example in Modified Quadratic Congruence, MQC (Zou, Ghafouri-Shiraz & Shalaby, 2001a) only exist for prime numbers, and prime power in Modified Frequency Hopping, (MFH) (Zou & Ghafouri-Shiraz, 2002a), only double weight in Double Weight (DW) code, an even number or odd number of weight in Modified Double Weight, MDW (Aljunid, Ismail, et al., 2004; Aljunid, Zan, Anas, & Abdullah, 2004), and Enhanced Double Weight, EDW (Abdullah, Hasoon, Aljunid, & Shaari, 2008); and also long code lengths such as Optical Orthogonal code (J. A. Salehi, 1989a), Prime code (G. C. Yang & Kwong, 1995) and Zero Cross Correlation (ZCC) code (Anuar et. al, 2007). Long code length requires a very wide bandwidth sources, hence it is considered a disadvantage in the code design implementation. Hence, there are still rooms of improvement in the OCDMA research and development to find a better code design that could overcome the limitations of the existing codes.

Another challenge in the key design issues of OCDMA lies in the spread spectrum nature of the OCDMA, making it an access scheme with lower spectral efficiency (Yan, 2008) compared to WDMA. Hence, one way of increasing the spectral efficiency of

OCDMA is by having hybrid system such as the OCDMA - WDMA (Kitayama & X. Wang, 2006; Galli, 2008; Djordjevic, 2004) or combining it with subcarrier multiplexing (SCM) scheme. In multi-service environments of high density communication network such in metropolitan area, the transmission capacity and the number of simultaneous users can be enlarged by using the subcarrier multiplexing (SCM) scheme that enables multiple RF signals to be transmitted simultaneously over the fiber-optic links (Kim, K. et.al., 2010).

The SCM is an attractive technique where it provides the independency of different channels. This allows for great flexibility in the choice of modulation schemes. With this technique, the information signals are modulated onto different electrical subcarriers in the radio or microwave domain and combined together to modulate the intensity of an optical carrier (Khaleghi & Kavehrad, 1995). At the receiving part, a photo detector will convert the optical signal into an electric current. To retrieve the original signal, the electric current will then be demultiplexed and demodulated using a conventional method. One significant benefit of SCM is that the electrical components and equipments are far less expensive than its optical counterparts are. In fact, the low implementation cost of SCM system has been proposed to transmit multi channel digital optical signals for LAN (Rongqing, et al., 2002).

The research on SCM in optical system has mostly been on the combination with WDMA scheme and been used for Radio-over-Fiber (RoF) or Fiber-Wireless (Fi-Wi) networks. To date, there are quite a number of published works done on the Fi -Wi or RoF networks architecture, mostly proposing on the WDM architecture on the optical side (Ghazisaidi and Maier, 2009 & 2011; Lim et. al, 2000, 2001 & 2003; Koonen, 2006; Wen et.al, 2003; and Opatc, 2009). Figure 1.1 illustrates a typical SCM-WDM architecture.

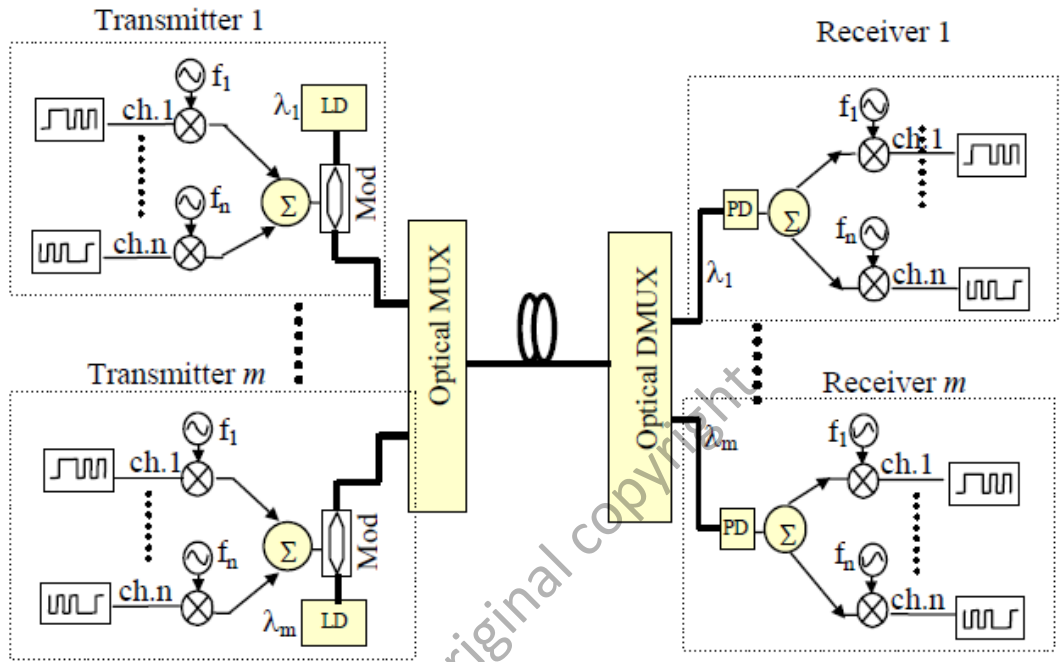

Figure 1.1: SCM/WDM basic architecture (Hui, R. et. al., 2004).

On the other hand, related work on the area of SCM-OCDMA has only been found in (Sahbudin et al., 2009; Sahbudin et al., 2011), where the authors evaluated the performance of this hybrid technique based on different detection techniques using one of the existing codes. Yet, the work on hybrid SCM-OCDMA technique still requires more attention. Considering this, in this thesis, a new code for the OCDMA is proposed and the hybrid SCM-OCDMA system based on this new code is developed theoretically and in simulation to investigate the system performance with various design parameters.

## 1.2 Research Objectives

Following the project motivations described in the previous subsection, this dissertation is orientated by the following research objectives:

- i. To develop a new Spectral Amplitude Coding OCDMA code that have the following properties: minimum cross correlation of one with minimum code