

Design of UHF Harmonic Butterworth Low Pass Filter For Portable 2 ways-Radio

Liew Hui Fang¹, Syed Idris Syed Hassan², Mohd Fareq Abd. Malek²
Yufridin Wahab¹ and Norshafinash Saudin²

¹ School of Microelectronic Engineering, University Malaysia Perlis, Perlis, Malaysia

¹alicefang88@yahoo.com

¹yufridin@unimap.edu.my

² Schools of Electrical System Engineering, University Malaysia Perlis, Perlis, Malaysia

²syedidris@unimap.edu.my

²mfareq@unimap.edu.my

²norshafinash@unimap.edu.my

Abstracts-This paper presents the design of a compact Butterworth low pass filter designed operating at frequency range of 300-400MHz with input and output impedance of 50 ohm have been designed, simulated and fabricated. This filter is used to attenuate harmonic that generated by power amplifier to prevent from radiating out through the antenna. The filter's circuits were first simulated using Advanced Design Software (ADS) to obtain the best filter characteristic based on S-parameter to see whether they met the specification for two way radio or not using the tuning and optimization features in ADS. From the measured results obtained from the fabricated filter, it is found that the performance of the filters do not satisfied according to the design specification value requirements. Comparing with the simulated circuits using ADS simulation software, the measured value also do not match. There many factors that influenced the results. This resulting the all the hardware measurement result low pass filter on each S-parameter show are not ideal as compared with the software simulation. The ADS based design has been prototyped and tested. Some optimization has been performed to improve the radio performance.

Keywords-Butterworth Filter, S-parameter, Harmonic filter, RF Communication, Maximally Flat

I. INTRODUCTION

A two-ways radio can transfer signal in two type of data system, which is analog and digital system. Two ways radio also can receive and transmitted the operating frequency in digital and analog frequency. But in the analog channel of the conventional system radio, the more important factors on it is frequency or channel can affect the communication information radio by serve a physical medium or link on it. The two-ways radio always faces the harmonic distortion between the transmitter channel and receive channel, in order to prevent it from affecting the output performance of receiver circuit, low pass filter of a better frequency response should be designed in order to allow signal pass through the two-ways radio which operating in frequency range of 300- 400MHz. The portable 2way radio functions as receive r and transmitter data inform ation system. Harmonic distortion can cause severe disturbance to certain electrical equipment[12]. However the design is very critical in choosing the right components since as the frequency is increasing, lumped elements become less and less ideal and all parasitic elements such as series resonances of inductors and parallel resonances of capacitors, and of course all resistive contributions will be the most concerned issue. This will affect the output performance of the low pass filter.

The Butterworth filter have maximally flat frequency response and not have ripple[10] response on the pass band. However, the Butterworth filter has maximally flat response as possible from 0 Hz until cut off frequency at -3dB on the passband with no ripple, and rolls off on the stopband are towards zero response. It can be describe and observed on the logarithmic bode plot [9-10], its shows that the response slopes off linearly towards negative infinity. Such as a first-order filter's response rolls off at -6 dB per octave (-20 dB per decade)[1-2] (all first-order lowpass filters have the same normalized frequency response). A second-order filter decreases at -12 dB per octave, a third-order at -18 dB and so on. Butterworth filters have a monotonically changing magnitude function with ω , unlike other filter types that have non-monotonic ripple in the passband and/or the stop band. [3-5]. This is also because it has a 'quality factor', "Q" of just 0.707 [1,5].

The Butterworth filter have specification characteristic that is defined as 'brick wall'[1,12], its represent the ideal frequency response and standard approximation of Butterworth filters measurement result. Butterworth filter have poor response of phase characteristic that is at stopband,[10,13] it's required the higher order to

implement in the specifications particulars on this stopband parts And the disadvantages of Butterworth filters is the passband of its al ways achieved the expense of wide transition band and the filters will make translation band from the passband to the stopband.

Butterworth harmonic filter is basically a low pass filter [1-2,6] that is responsible in attenuating any harmonics over range of operating signal to damages the output performance. This filter could suppress the harmonics to minimal extent in order to eliminate the spurious problem[7-8]. The characteristic of frequency band of radio are related with the performance of a radio system. If the output received of the performance of radio can be improved by frequency bands adjusted on it. The common frequency bands of two –ways radio can be categories into the UHF (ultra high frequency) and VHF (very high frequency). The wavelength of UHF bands are shortest that VHF. The advantages UHF shortest wavelength a suitable for use on the rugged terrain or inside of a building which signal easier to transfer and find the ways to pass through on it.[1] But for VHF have a longer wavelength and it can make signal transmit further under ideal condition. In general, lower radio frequencies are more better when compare to longer range using in any electronics application[6, 11].For design of Butterworth filter into radio communication applications, the important consideration include type of elements circuit. The lumped elements circuit can work efficiency at lower frequency UHF because the wavelength will decrease to short on higher frequency and while for distributed elements suitable operate at higher frequency and wavelength will become too larger when into lower frequency range[12,16].

In this paper, Butterworth filter are development into UHF range as harmonic filter into portable 2 radio application by allow the desired frequency signal to pass through antenna and attenuate the higher signal frequencies and to reduce the minimal losses. Minimal losses on signal transmission reduces energy consumption during communication thus making this product potentially invaluable for signal transmission on regions whereby a power source is difficult to locate. To achieve better performance, the design of Butterworth are concentrate on lumped elements compare to distributed elements. The two ways radio experience harmonic produced by the transmitter and entering the receiver. These will damage the receiver circuit. In order to solve this, a low pass filter is to be employed such that it will attenuate the harmonic signal and allow the wanted signal to pass through antenna with minimum losses. Butterworth filter are devices of combination of two –port network which used on function as to control the certain frequency signal repossesses within a system by only allowing the transmissions of specify frequencies signal pass through in passband and discriminate the unwanted frequency in the stopband. By this method, the harmonic filter is also use to attenuate the excessive harmonic that generated by transmitter chain.

II. METHODOLOGY AND TECHNIQUES

A. Filter specification and design

Table 3.1 are the specification required for transmitter and receiver. In designing the low pass filter we need such that S_{21} at pass band must be less than -1 dB loss, the return loss at input and output , S_{11} and S_{22} , respectively should be less than -15 dB and the attenuation (S_{21}) at $2 f_c$ is -45 dB. The frequency range for the low pass filter should allow is 300 – 400 MHz.

TABLE 1
The transmitter and receiver S-parameter Spec value

parameters	values
Operating freq:	300-400MHz
Tx insertion loss:	>-1dB
Tx Input return loss:	<-15dB
Tx Output return loss:	<=15dB
2Fc attenuation:	<-45dB
Rx insertion loss:	>-1dB
Rx Input return loss:	<-15dB
Rx Output return loss	:<=15dB
2Fc attenuation:	<-45dB

B. Design of Butterworth Low Pass Filter

The design was based on filter design calculator available in the website [15]. The steps are as follow:-

- I. Filling the specification in the calculator as shown in Figure 3.4 below.

Type Lowpass ▾
 Poles 7 ▾
 450 MHz ▾ 3 db cutoff frequency
 50 I/O Impedance in ohms

Compute Parts Values Reset

Fig 1. Instruction of Design an L-C low pass or high pass filter

7 pole lowpass filter

I/O impedance = 50.0 ohms
 3 DB cutoff freq = 450.0 MHZ

Best for low impedance loads.

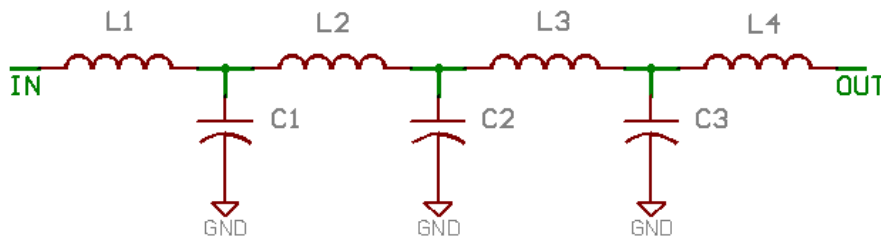

Fig 2. The 7 poles circuit design by filter calculator

The corresponding value for circuit in Figure 2 for Butterworth, Chebyshev and Bessel are given in Table 2 below.

TABLE 2
 Part value L&C of low pass filter design by filter calculator

Part	Part Values		
	Butterworth	Chebyshev 0.1 DB	Bessel
L1	0.008 uH	0.022 uH	0.002 uH
L2	0.032 uH	0.040 uH	0.009 uH
L3	0.032 uH	0.040 uH	0.015 uH
L4	0.008 uH	0.022 uH	0.040 uH
C1	8.82 pF	10.75 pF	2.31 pF
C2	14.15 pF	11.89 pF	4.97 pF
C3	8.82 pF	10.75 pF	7.82 pF

This web based application allows the user simply to design simple radio frequency filters with inductors connection in series and capacitors in parallel connection. These filters are most effective between 50 kHz and 500 MHz. Below 50 kHz active filters are usually more cost effective and above 500 MHz, microstrip lines are generally used.

C. Microstrip line design

In this project work, a microstrip transmission line as shown in used to match and connecting the chip components. The microstrip was designed for 50 ohm that is suitable for the operating frequency range around

300-400MHz using FR-4 PCB [14]. The impedance matching also is play an important role in microstrip line design, when the simple lumped element network must be able to accomplished with the input and output circuit impedance or with the transmissions line of equivalent short circuits matching. A useful set of relations for the characteristic impedance, assuming zero or negligible thickness of the strip conductor, is as follow [1,6]:

For $W/h \leq 1$: [1]

$$Z_o = \frac{60}{\sqrt{\epsilon_{ff}}} \ln\left(8 \frac{h}{W} + 0.25 \frac{W}{h}\right) \quad (1)$$

Where

$$\epsilon_{ff} = \frac{\epsilon_r + 1}{2} + \frac{\epsilon_r - 1}{2} \left[\left(1 + 12 \frac{h}{W}\right)^{-1/2} + 0.04 \left(1 - \frac{W}{h}\right)^2 \right] \quad (2)$$

For $W/h \geq 1$ [1]

$$Z_o = \frac{120\pi / \sqrt{\epsilon_{ff}}}{\frac{W}{h} + 1.393 + 0.667 \ln\left(\frac{W}{h} + 1.444\right)} \quad (3)$$

Where

$$\epsilon_{ff} = \frac{\epsilon_r + 1}{2} + \frac{\epsilon_r - 1}{2} \left(1 + 12 \frac{h}{W}\right)^{-1/2} \quad (4)$$

Width:

$$A = \frac{Z_o}{60} \sqrt{\frac{\epsilon_r + 1}{2}} + \frac{\epsilon_r - 1}{\epsilon_r + 1} \left(0.23 + \frac{0.11}{\epsilon_r}\right) \quad (5)$$

$$B = \frac{377\pi}{2Z_o \sqrt{\epsilon_r}}$$

$$\frac{W}{d} = \begin{cases} \frac{8e^A}{e^{2A} - 2} & \text{for } W/d < 2 \\ \frac{2}{\pi} \left[B - 1 - \ln(2B - 1) + \frac{\epsilon_r - 1}{2\epsilon_r} \left\{ \ln(B - 1) + 0.39 - \frac{0.61}{\epsilon_r} \right\} \right] & \text{for } W/d > 2 \end{cases} \quad (6)$$

Where W= width of microstrip

h =thickness of substrate

ϵ =dielectric constant

III. RESULT AND DISCUSSION

The low pass filter (transmitter and receiver) operating frequency range is at 300-400MHz, cutoff 450MHz on a substrate that had a dielectric constant of 4.5 and a thickness of 1.5 mm with the expected simulation result S-parameter of software before and after tuning to low pass filters designed and it is shown as below graph, and for lumped elements capacitor and inductor value per design was done by using ADS software. Tuning method is using in order to perform better simulation result according to specification values required. The method are done by trying change some of parameter values and until make the simulation result close to specification values.

A. Below Figure 3 and figure 4 show the lumped elements circuit of Butterworth filter design by ADS cut off at 450MHz

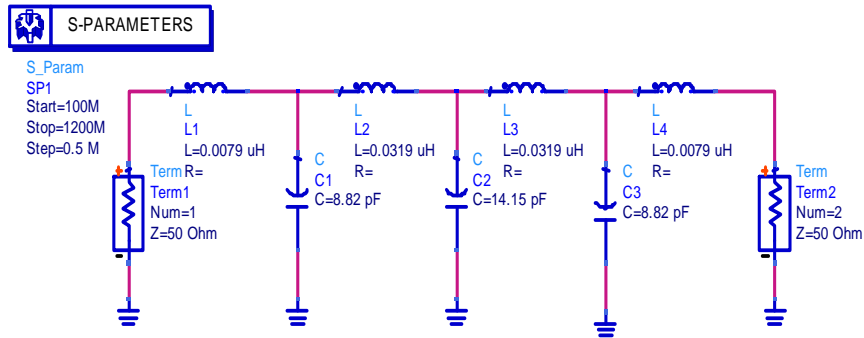

Fig 3. Butterworth low pass filter before tuning cutoff at 450MHz

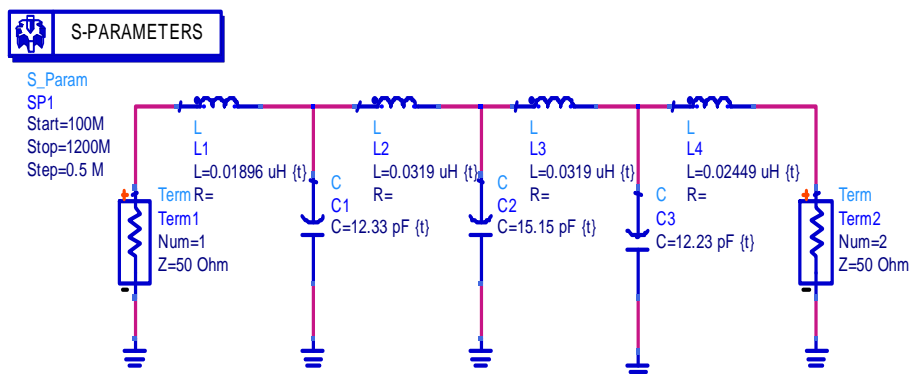

Fig 4. Butterworth low pass filter after tuning cutoff at 450MHz

B. The graph below Figure 5 and Figure 6 show the Butterworth filter simulation result on ADS before and after the tuning method apply to improve the circuit output performance .

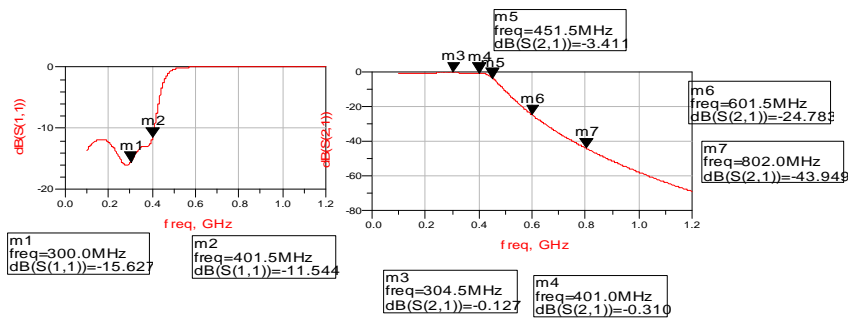

Fig 5. Actual simulation S-parameter result before tuning

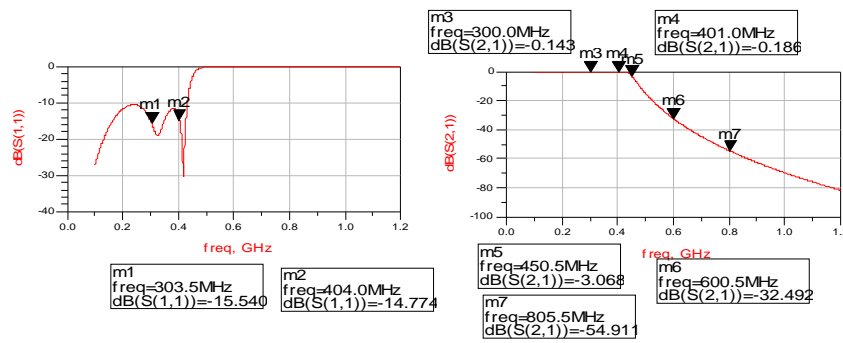

Fig 6. Simulation S-parameter result after tuning

TABLE 3

The table about the simulation result Butterworth low pass filter before and after tuning cutoff at 450MHz

S-Parameter (dB)	Tx-input return loss		Tx -insertion loss		2Fc attenuation		-3dB cutoff
	S11 (dB)		S21(dB)				S21(dB)
Operating frequency range(MHz)	300	400	300	400	600	800	450
Before Tuning	-23.875	-7.459	-0.019	-0.620	-17.946	-35.215	-3.200
After Tuning	-14.995	-14.238	-0.128	-0.156	-32.842	-54.514	-3.392
Spec value	<-15	<-15	>-1	>-1	<-45	<-45	-3.0

C. The graph below Figure 7 and Figure 8 show the Butterworth filter measurement result on hardware Butterworth filter.

The measurement result for S11&S21 from the graph, observe that all the S-parameter value are out of the spec when we compare with spec simulation result, shifting case occurs on each S-parameter result due to some factors and just can obtain the filter design graph waveform but the value is fail to achieved. The shifting case make the S21 h as a slower roll-off filter and no have ripple on passband and it required a higher order to implement a particular specification at stopband parts.

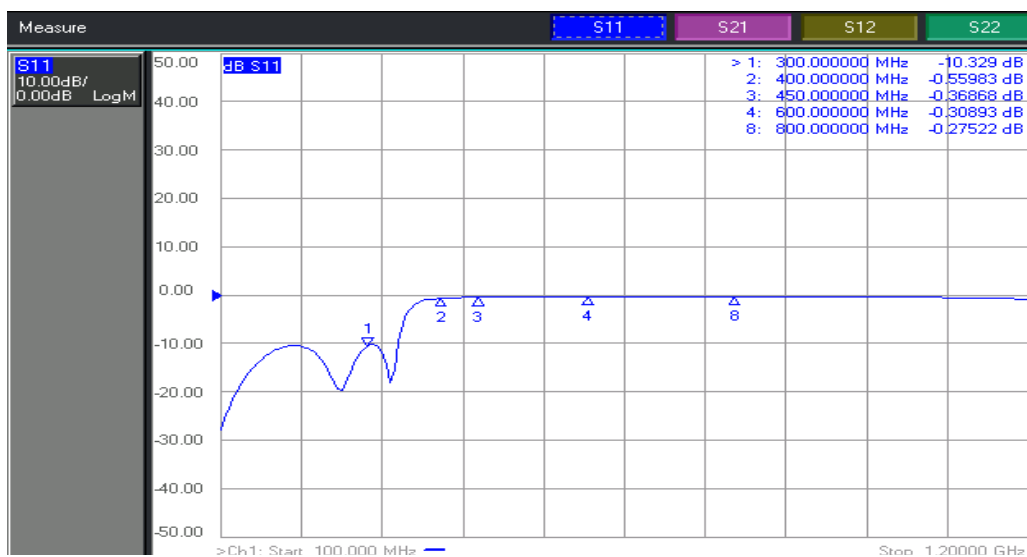

Fig 7. Simulation S11 results for Butterworth low pass filter



Fig 8. Simulation S21 results for Butterworth low pass filter

TABLE 4
Simulation S-parameter results for Butterworth low Pass Filters on hardware measurement

S-Parameter (dB)	Tx-input return loss		Tx –insertion loss		2Fc attenuation		-3dB Cutoff
	S11(dB)		S21(dB)				
Operating frequency range(MHz)	300	400	300	400	600	800	450
Measurement Value	-10.329	-0.5598	-1.5695	-23.359	-74.987	-63.217	-37.555
Spec value	<-15	<-15	>-1	>-1	<-45	<-45	-3

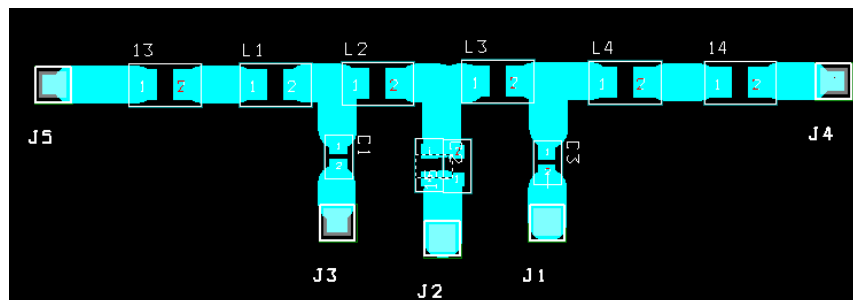

Fig 9. The layout of Butterworth filter design by using orcad



Fig 10. Hardware Butterworth low pass filter

IV. ANALYSIS AND DISCUSSIONS

The filter circuits that were designed from formula or theory were simulated using ADS software from Agilent. The results were found to be far away from the specification. In order to meet the specification, the simulated circuits were tuning or optimized. The S-parameter values after using tuning method had come to almost nearest to specification value that were required. Overall of the ADS software simulation result

Butterworth filter have shown that ideal and able to perform as a better filters response and all the S-parameter value appropriate to the specification value required for the filter design.

From the experiment we can see there are some differences between the measured values with of the actual value and after tuning value. The measured values of low pass filter is also far away from the specification value. However the components used were slightly difference from the optimized value because it is impossible to get the exact value from the market.

As we know the simulation software ADS result is done on the very prefect and ideal condition whereas components value are just on the shelve that closed to the specification value requirement. Some of the problem in fabricating the circuits are lack of soldering skill, appropriate components value such as chip capacitor and chip inductor, suitable length of microstrip and measurement skill.

After fabrication process is done, the hardware fitter is produce and the filters S-parameter is can be measure by using Agilent network analyzer E8362B. From the above result shown that the measurements Butterworth filters produce the output response same as simulation. Even from the above graph simulation result, we can observed that the S-parameter value almost all is out of spec required, it is due to some main reason who cause to this effect of soldering skill, and distance of length between component in the microstrip line design, exact value of L & C are not available, problem of PCB layout design by Or-card software and shifting case occurs on the graph waveform.

V. CONCLUSION

From the simulation results, it is noticed that the ads software simulation show the ideal result of Butterworth filters is the best and able to perform the better filters response and all the S-parameter value are appropriated to the specification value required for filter design. But when in measurement result of filter response has the shape as low pass filter. So we conclude that design is not fail. By taking care all precaution a good filter can be designed. Overall, the simulation result and measurement result are agreed well with each other. The design can be further improved in accuracy through using a better technology for better fabrication and more pure substrate and copper that we using in fabrication. Besides, to improve the transition band, which gives us a better and narrower slope, we can increase the order of the filter, but in other way round, it also will increase the cost of the filter. In other words, to improve the cost effectiveness, we can reduce the order of the filter as well.

ACKNOWLEDGMENT

The authors acknowledge University Malaysia Perlis and the Malaysian Ministry of Higher Education for providing the Fundamental Research Grant Scheme (FRGS Grant No: 9011-00011), which made it possible to conduct and publish this research.

REFERENCES

- [1] David M. Pozar., Microwave Engineering, 3rd Edition, John Wiley & Sons, Inc. Canada.2005, pp422-459.
- [2] Jiashen G.Hong and M.J.Lancaster, "Basic Concepts and Theories of Filters," In: *Microstrip Filters for RF/ Microwave Applications*, John Wiley & Son Inc, 2001, ch.3, pp.29-47.
- [3] Les Besser and Rowan Gilmore, "Filters and Resonant Circuit," In: *Practical RF Circuit Design for Modern Wireless System, Passive circuit in Systems*, voll1, Artech House, Boston, and London, 2003, ch.8,pp.429-435.
- [4] Roman Kaszynski and Jacek Piskorowski, "New Concept of Phase-Compensated Butterworth Filters," *IEEE Electrotechnical Conference Melecon Benalmádena (Málaga), Spain*, pp. 529-532, 2006.
- [5] Roman Kaszynski and Jacek Piskorowski, "New Concept of Delay-Equalized Low Pass Butterworth Filters," *IEEE Symposium on Industrial Electronics and Application (ISIEA 2009)*, vol. 1, pp. 171-175, 9-12 July, 2006.
- [6] G. Matthaei, L. Young, and E. M. T. Jones, "Microwave Filters," In: *Impedances- Matching Networks, and Coupling Structures*. Norwood, MA: Artech House, 1980, ch.7, pp. 355-419.
- [7] Devendra K.Misra, "Filter Design," In: *Radio Frequency and Microwave Communication Circuit, Analysis and Design*, John Wiley & Sons, Inc. Canada, 2001, ch. 8, pp. 295-351.
- [8] Jyh-Wen Sheen, "A Compact Semi-Lumped Low-Pass Filter for Harmonics and Spurious Suppression," *IEEE Transactions On Microwave Theory And Techniques*, vol. 10, No 3, pp.92-93, March 2000.
- [9] Li Zhongshen, "Design and Analysis of Improved Butterworth Low Pass Filter," *The Eighth International Conference on Electronic Measurement and Instruments*, pp. 1729-1732, 2007.
- [10] Anju and Mamtta Katiyar, "Design of Butterworth and Chebyshev 1 Low pass Filter for Equalized Group Delay," *International Journal of Advanced Research in Computer Science and Software Engineering*, vol. 2, Issue 5, May 2012.
- [11] R. Levy, R.V.Snyder and G. Matthaei, "Design of Microwave Filters," *IEEE Transactions On Microwave Theory*, vol.50, pp.783-793, March 2002.
- [12] Vadim Kim, "How to Design 10 kHz filter (Using Butterworth filter design)," PhD Thesis, Brandeis University, US, 1998.
- [13] Electronics Tutorials WS. (2012, March 12). Electronics Tutorial about Butterworth Filters-Butterworth Filter Design, Wayne Storr. Available: http://www.electronics-tutorials.ws/filter/filter_8.html
- [14] Unknown Author. (2102, April 12). PCBs Fabrication Methods, [Online] Available http://www.technick.net/public/code/ep_dpage.php?aiocp_dp=guide_pcb
- [15] Unknown Author. (2008, May 18.). Design an L-C Low pass or High pass Filter [Online] Available: http://www.wa4dsy.net/filter/hp_lp_filter.html
- [16] Unknown Author. (2008, April 18). Devoted to RF & Microwave Filter Theory and Design How do Filters Work. [Online] Available: <http://www.rfcurrent.com/how-filters-work>