

THE IMPACT OF DIRECT LIGHTNING STRIKE DAMAGES ON PV MODULES IN A LARGE MALAYSIAN PV FARM

(Date received: 03.09.2021/Date accepted: 28.06.2022)

Thum Peng Chew¹, Sean Lee Xi Xian²

¹TPC Solutions, No. 3 Jalan SS24/19, 47301 Petaling Jaya, Kuala Lumpur.

E-mail: thumpc@gmail.com

²Jacobs Engineering Group Malaysia Sdn. Bhd.,
Suite E-17-P2, Level 17 (Penthouse), Block E,
Plaza, No., 2, Jalan Kiara, Mont Kiara, 50480 Kuala Lumpur, Wilayah Persekutuan.

E-mail: xixianlee@hotmail.com

ABSTRACT

Many lightning risk analyses avoided considering the role of the PV Module's aluminium frame as a natural lightning air termination system or if such a role is considered, assumed that the 'thin' aluminium frame, would not be damaged from metal melting and evaporation at the point of lightning stroke attachment. Although the IEC 62305 is not lacking in guidance on the use of thin metal sheets as air terminations, this aspect is not considered in PV farm design. To ensure correct inputs into the risk assessment calculation, the evaluation of interception and sizing efficiencies and the damage probabilities of the natural components have to be addressed. A comparative analysis is done between two types of air terminations; the PV-frame LPS and the finial-added LPS. The result indicates that for solar PV farms exceeding a certain size and operating in high ground flash density regions like Malaysia, the finial air termination may out-perform the PV-frame LPS.

Keywords: Lightning Protection System, Interception Efficiency, Hot-spot Puncture, Sizing Efficiency, PV Module Damage Rate, PV Module Replacement Rate

1.0 INTRODUCTION

The IEC 62305 method which was originally intended for lightning protection of buildings and structures, has been adopted by the Malaysian Solar PV Industry as the basis for PV farm lightning risk analysis. Many of such analyses avoided considering the role of the PV Module's aluminium frame as a natural lightning air termination system or if such a role is considered, assumed that the 'thin' aluminium frame, would not be damaged by thermal melting and metal evaporation at the point of stroke attachment. Such assumptions have guided the risk analysis of smaller MW-output solar PV plants. Also for cost-saving reasons, lightning protection system (LPS) design would inevitably make use of the PV string support structures and foundations and their metal frames as a natural-component system. While the IEC 62305 is not lacking in guidance on the use of thin metal sheets as air termination, many risk analysis are accompanied by a lesser emphasis on the air termination interception and sizing efficiency checks. Consequently, the damage probability of the natural components is not accurately determined. To ensure correct inputs into the risk assessment calculation, the evaluation of interception and sizing efficiencies (IE and SE respectively) and the damage probabilities of its natural components, have to be addressed.

The purpose of the work reported here is to determine both the interception efficiency of the LPS and sizing efficiencies of the natural components, estimate the damage rate, discuss its implication on and improvement of the performance of the lightning protection system and how much it impacts the PV farm's service life in terms of its mean-time-to-failure, MTTF and its PV module replacement rate which is a factor in cost calculation.

2.0 SIZING AND INTERCEPTION EFFICIENCIES OF THE LPS

The IEC 62305-1 [1] recognizes two causes of damages. The first is due to mechanical stress, arcing and overheating by high stroke currents. The second is due to shielding failure from weak first strokes. The first cause is represented by the LPS sizing efficiency, SE or by sizing failure rate, $SF = 1 - SE$. The second cause gives rise to overvoltage due to stroke penetration and can be expressed as shielding failure rate, $SFR = 1 - IE$. Both SE and IE must have near 1.0 efficiency if damage probability is to be near zero. Tables 3, 4 and 5 of Reference [1] gives the CIGRE data for the derivation of damage probability for LPL 1 to LPL 4. The derivation is reproduced in Table 1 below.

2.1 Sizing Efficiency, SE of the Aluminum Frame

From Table 1 and Figure 1, the SE of LPS Class I due to a large 200 kA ($I > 200\text{kA}$, prob. $\leq 1\%$.) stroke is $100\% - 1\% = 99\%$ or 0.99 pu. Thus, its sizing failure rate, SF = 1% or 0.01 pu.

Sizing efficiency, SE is determined from a number of stroke parameters representing the various failure mechanisms at the point of strike. They are given in Table D1 of Reference [1]. There are two thermal mechanisms, i.e. resistive heating and arc-root melting. Of particular significance to the PV module aluminum frame is the thermal damage resulting from the more dominant and severe arc-root melting at the immediate region around the stroke attachment point. Reference [1] recognizes this and uses a thermal arc-root voltage drop model for evaluating the arc-melting effects that cause metal punctures and hot-spots.

Table 1: IEC 62305 Damage Probability from Reference [1]

Parameters	Lightning Protection Level/ LPS Class			
	I	II	III	IV
Sizing Efficiency, SE	0.99	0.98	0.95	0.95
Interception Efficiency, IE	0.99	0.97	0.91	0.84
Total Efficiency	0.98	0.95	0.90	0.80
Damage Probability, P_B	0.02	0.05	0.10	0.20

Note: $P_B = 1 - IE \times SE$

2.2 Interception Efficiency, IE of the LPS

The interception efficiencies in IEC 62305 are directly derived from the CIGRE Stroke Current Cumulative Distribution as shown in Figure 1. In Table 1, they are equated to the stroke current probabilities for the various LPS without the rigor of probabilistic Rolling Sphere Method (RSM) analysis. As such from Figure 1 for LPS I, a shielding failure rate (SFR) due to 3kA stroke current is $1 - 0.99 = 0.01$ pu which implies a 0.99 pu or 99% interception efficiency as shown in Table 5 of Reference [1]. The assumption is then made that a shielding failure from even a low current stroke will always lead to damage from a large shielding failure overvoltage.

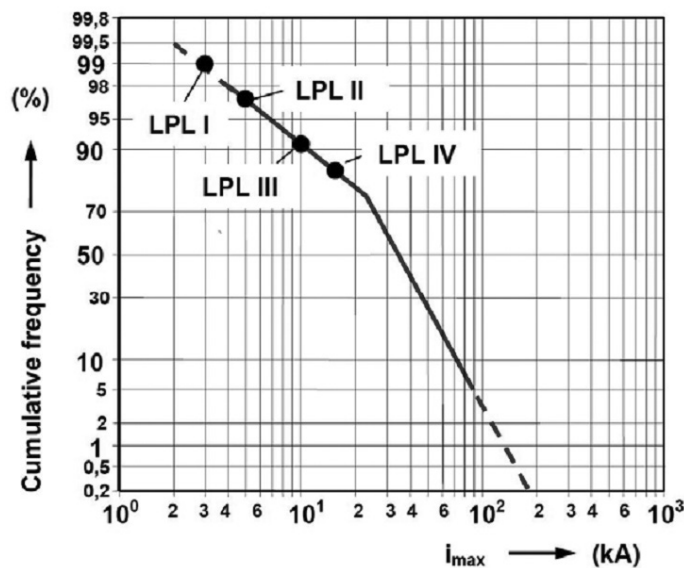

Figure 1: CIGRE Stroke Current Cumulative Probability Distribution

2.3 Damage Probability, P_B of the PV Module

In practice, the damage probability, P_B is derived according to the formula given under Table 1. Using it, automatically assumes that the sizing efficiency of the natural air termination components is near 100%. Table B.2 of Reference [2] gives the damage probabilities, P_B either for not providing any lightning protection measure (LPM) or for providing one of the four IEC 62305 type LPS. Although Reference [1] allows for detailed investigation taking into account the requirements of sizing and interception criteria, this is usually not done. When a natural air termination component is used, Table 3 of Reference [3] points to a minimum aluminium sheet thickness of 7 mm in order to avoid puncture, hot-spot or ignition problems. Thus, as shown in Figure 2, the thin aluminium frames are possible sites/locations of physical damage on the exposed PV modules. They may also present life safety hazards in the PV farm.



Figure 2: Damaged PV Module Aluminum Frame Caused by Lightning Stroke Attachment

3.0 THE PV FARM DAMAGE PROBABILITY

3.1 Interception Efficiency of Finials

The accuracy of the LPS interception efficiency estimate can be improved by carrying out probabilistic RSM evaluation of a typical LPS design. Reference [4] examined this by using a dynamic electro-geometric model (DEGM) in a probabilistic analysis to derive representative estimates of IE. The results for a finial-based LPS system is summarised in Table 2.

Table 2: Interception Efficiencies of Air-Termination Rod Systems for Rod Separation Distances, d Derived from DEGM [4]

LPS Class	Interception Efficiencies of Air-Termination Rods placed at Roof Corners, Edges and Centre in % for Separation Distance, d m and in brackets, min. rod height, h m			
	$d = 5$	$d = 10$	$d = 20$	$d = 40$
I	99.97(0.3m)	99.97(1.3m)	99.96 (5.9m)	-
II	99.92(0.2m)	99.92(0.9m)	99.93(3.6m)	99.74(20m)
III	99.83(0.15m)	99.84(0.6m)	99.81(2.3m)	99.79(10m)
IV	99.53(0.1m)	99.56(0.4m)	99.64(1.7m)	99.65(7.1m)

Table 2 shows the typical DEGM IE estimates based on the separation distance of the air-termination rods. The IE values lie within a narrow range of 99.5% to 99.9% as compared with those in Table 1. The DEGM allows the IEs to be improved;

more precisely, by a combination of the finial height, h and finial separation, d . The results show that by probabilistic analysis with RSM, the likely IE may be > 0.995 , giving a SFR < 0.005 . Comparison between Tables 1 and 2 seems to suggest that the DEGM presents some possibility to adopt IE values higher than those of the IEC LPS classification.

To achieve an IE of at least 99.5% in actual application to a PV farm, Table 2 suggests that the rods/finials should be long enough ($h > 0.3\text{m}$) and positioned dense enough ($d < 10\text{m}$ separation) in the farm. However, shading avoidance requires h to be short. Thus, this criterion puts a limit to the finial's maximum height, say to less than 1.3 m.

In other words, for a conservative IE = 0.995, the PV farm LPS design can be guided by two conditions:-

1. Finial Height, h : 0.3 - 1.3 m
2. Finial Separation Distance, d : less than 10m

When bounded by these two conditions, the LPS design need not be type-classified. However, as required in all new designs, it is prudent to complete a probabilistic EGM analysis of at least, a representative multiple PV string block of a new PV farm.

3.2 Damage Probability of the PV Module Aluminum Frame

If the efficiency of an LPS's air termination is IE, its PV damage probability, $P_{BI} = IE \cdot P_{HS}$ where P_{HS} is the air-termination's hot-spot damage probability. In maintaining high IE, it becomes prudent to ensure that the air-termination's hot-spot damage probability, P_{HS} is small.

In practice, the top layer of the PV module aluminium frame naturally acts as a mesh air termination network. Without any added external air termination, lightning strokes will terminate on the rectangular meshes. Normally, the aluminium metal is only about 1.5mm - 2mm thick as shown in Figure 3. Such a thin layer would not serve well as air-termination because stroke termination on the aluminium mesh could result in deep melts and high temperature at its opposite underside to cause damage to the PV contact surface [5]. The damage probability of the aluminium layer can be estimated by using a 2-phase thermal arc-root voltage drop model given in the IEC 62305 [1] and applied to the probability distribution of lightning flash charges.

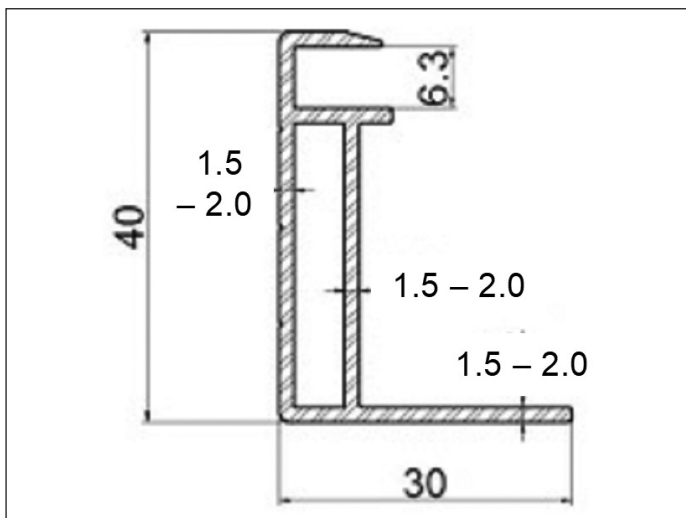

Figure 3: The Structure and Typical Thickness, in mm of PV Module Aluminum Frame

The volume, V of melted metal of a thin sheet is a function of arc-root voltage drop, U and equivalent charge transfer, Q :-

$$V = \frac{uQ}{\gamma(C_w(\theta_s - \theta_u) + C_s)} \quad (1)$$

where

V is the volume of metal melted, (m^3)

U is the arc-root voltage drop (assumed constant),
(= 10 V for anode [6])

Q is the effective charge of the lightning current, (C)

γ is the aluminium density, ($2,700 \text{ kg/m}^3$)

C_w is the thermal capacity of aluminium, (908 J/kg.K)

θ_s is the melting temperature of aluminium, (658°C)

θ_u is the ambient temperature, (32°C)

C_s is the latent heat of melting of aluminium, ($397 \times 10^3 \text{ J/kg}$)

Other parallel mechanisms of resistive heating, vaporization, radiation, etc. are small compared to melting. Resistive heating comes from the flow of lightning surge current whereas arc-root plasma melting comes from the lightning charge transfer over a long duration of 0.5 seconds. Arc-root melting is dominant in the charge transfer mechanism. Thus, an estimate of the total charge transfer can be made by using a melting efficiency factor to account for losses from metal sputtering or ablation and the other parallel mechanisms. Guided by [5] and [7], it is estimated to be 87.5%. Thus, the long duration lightning charge transfer to produce total melting effects that are partly represented by Q is $Q_L = \frac{Q}{0.875}$.

Following the spot-melting model of [8], the metal volume of the single spot that is melted by the effective charge, Q is approximated by a hemisphere with a radius equal to the thickness of the aluminium. It represents a single-spot melt-through volume, V and excludes metal loss in sputtering or ablation around the spot itself.

The cumulative probability of the total negative lightning charge, Q_L including subsequent stroke charges that are transferred to the spot is given in [5] and [9] as :-

$$P = \frac{1}{1 + \left(\frac{Q_L}{7}\right)^{1.7}} \quad (2)$$

Thus, the derived lightning charge, Q_L can be used to estimate the probability of it being exceeded. A smaller charge will lead to a higher damage probability. This probability can be taken as the sizing failure probability. Table 3a gives the calculated lightning charge probability which is equated to the frame's hot-spot damage probability, P_{HS} . The hot-spot damage probability, P_{HS} is equal to 0.6399. When it is combined with a high IE, the LPS damage is not tolerable.

Table 3a: Calculation of Damage Probability of Aluminum Frame

Input	Aluminium
Ambient Temperature, C	32
Arc-root Voltage Drop, V	10
Metal Thickness, mm	2
Melting Efficiency, pu	0.875
Melt Volume, $V \text{ mm}^3$	16.755
Effective Charge, C	4.367
Lightning Charge, C	4.991
Lightning Charge Probability	0.6399

Table 3b shows the reduction in damage probability with increase in aluminium thickness. It confirms that the IEC 62305 recommendation of 7 mm aluminium thickness is reasonable; its hot-spot damage probability is 0.003. Table 3b suggests that to reduce P_{HS} , the thickness of the aluminium layer has to be increased. To do so is costly. A more cost-effective engineering solution may be achieved by adding to the natural-component LPS, steel finials arranged according to the criteria developed in the previous section. Their role is to preferentially intercept lightning strokes and achieving high IE (99.5%). The aluminium mesh's role can then be relegated to an Electromagnetic (EM) screening function.

*Table 3b: Hot-spot Damage Probability vs
Aluminium Frame Thickness*

Aluminium Frame Thickness, mm	Hot-Spot Damage Probability, P_{HS}
2	0.6399
3	0.1835
4	0.0493
5	0.0163
6	0.0065
7	0.0030

4.0 EVALUATING THE LIGHTNING DAMAGE RATE OF A PV FARM

The PV farm structure is characterised by an extensive low-height and isolated-surface area. It physically resembles a shielded open-structure since the PV modules are made of aluminium frames which are bonded and earthed. Naturally and inevitably, the frames act as LPS mesh networks. Most stroke terminations are characterized by S1 overhead downward flashes with little or no side stroke terminations. Shielding failure is influenced by finial height and finial positioning or the lack of them. Cost-saving considerations compel the natural components of the PV module support structure and foundations to be used as the LPS down-conductor and earth systems as shown in Figure 4. Using their large metal cross-sections to distribute the large stroke current help reduce resistive heating effects and would not contribute to damage.

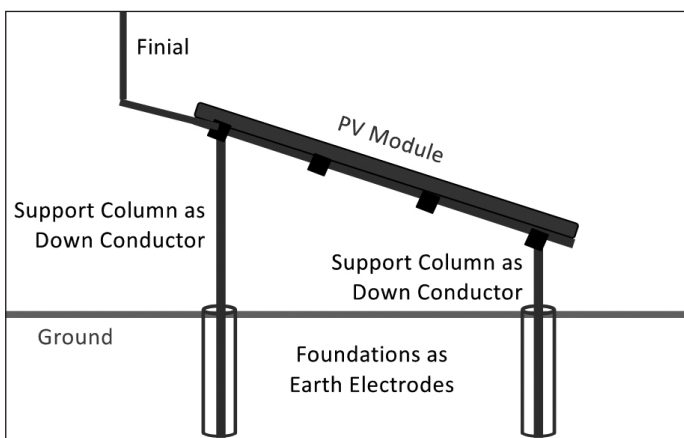

Figure 4: PV Module Support Structure Acting as LPS

For a PV farm, there are two damages; one, P_{B1} arising from successful stroke interception and the other, P_{B2} from shielding failure. The total damage probability of a PV farm is thus:-

$$P_B = P_{B1} + P_{B2} \quad (3)$$

where

$P_{B1} = IE \cdot P_{HS}$ P_{HS} is the hot-spot damage probability of the air termination

$P_{B2} = (1-IE) \cdot P_{OV}$ P_{OV} is the damage probability of the protected PV surface due to overvoltage.

Based on the above equation, the damage probabilities are calculated in Table 4 with $IE = 0.995$ for two LPS air terminations. One is obtained by adding external steel finials to the natural component LPS. The other makes use of the available PV module aluminium frames as air termination in an effort to save cost.

The cause of large P_{B1} is the high hot-spot probability, P_{HS} due to metal melting. Its value was inaccurately taken to be small in many risk analysis calculations and it led to the selection of the PV-frame LPS as a techno-economic solution in many instances.

Shielding failure does not always lead to damage if the PV module impulse withstand voltage is high. Laboratory tests have shown that certain c-Si PV modules can withstand up to 35 kVp impulse voltage without damage [10]. With limited data, P_{OV} is taken to be 0.5. The results of the damage rates show that the contribution to P_B improvement from impulse overvoltage withstand is small in both cases. P_{OV} contributes less significant improvement if P_{HS} is large as in the case of the PV-frame alternative.

*Table 4: Lightning Damage Rate for Various
Air Terminations And PV Module Impulse Withstand*

LPS Air Termination	14mm Dia. Steel Finials	2 mm Aluminium Frame		
Interception Efficiency, IE	0.995	0.995	0.995	0.995
Hot-Spot Damage probability, P_{HS}	0.005	0.005	0.6399	0.6399
$P_{B1} = IE \cdot P_{HS}$	0.004975	0.004975	0.6367	0.6367
Shielding Failure Rate, SFR = $1-IE$	0.005	0.005	0.005	0.005
PV Surface Damage Prob., P_{OV}	1.0	0.5	1.0	0.5
$P_{B2} = (1-IE) \cdot P_{OV}$	0.005	0.0025	0.005	0.0025
$P_B = P_{B1} + P_{B2}$	0.009975	0.007475	0.6417	0.6392

The larger damage rates pertaining to the aluminium frames have to be reduced because PV failures lead to loss of production and increase in maintenance and replacements which may cost more than the initial cost saving during construction. The result points to the need to reduce P_{B1} which implies reducing P_{HS} . Since the aluminium frame thickness cannot be changed, a viable improvement is to add short external finials to the natural-component LPS.

5.0 LIGHTNING PROTECTION PERFORMANCE OF THE LPS

Following the IEC 62305 method, the annual number of dangerous events due to lightning in tropical Malaysia is calculated on a per MW_{ac} output basis by using a land-use intensity of around 4 acres/MW_{ac}, a PV module surface area utilization parameter expressed as 2.063m²/350W, and a ground flash density of 30 flashes/km²-year. The PV module surface area utilization parameter allows the number of dangerous events to be calculated for different PV modules. The ground flash density (GFD) is calculated from CIGRE's formula [11] since the IEC 62305 GFD formula is only applicable to temperate regions. Using the IEC 62305 method of calculating annual dangerous events, a rate of 0.432 dangerous events/year-MW_{ac} is derived. It is noted that this value is proportional to the PV module surface area utilization parameter and to the GFD.

If the output of the PV farm is S MW_{ac} and it is protected by an LPS system giving a damage rate of P_B, then the estimated annual lightning damage, N_{DB} of the solar PV plant is given by:-

$$N_{DB} = 0.432 \times P_B \times S \tag{4}$$

N_{DB} can be interpreted as the average damage rate of PV modules. N_{DB} is small if the GFD is small, as in temperate regions.

Based on the above equation, the estimate of the PV farm's mean-time-to-failure (MTTF)

$$MTTF = \frac{1}{N_{DB}} \tag{5}$$

Table 5 compares the lightning protection performance of the finial-added LPS with that of the PV-frame LPS.

Table 5: Comparison of LPS Performance (Annual Damages and MTTF)

Plant Size, MW _{ac} Output	Annual Damages		Mean-Time-To-Failure, years	
	14mm Dia. Steel Finials	2 mm Aluminium Frame	14mm Dia. Steel Finials	2 mm Aluminium Frame
1	0.0043	0.277	232	3.61
2	0.0086	0.554	116	1.80
5	0.0215	1.386	46.4	0.721
10	0.043	2.772	23.2	0.361
15	0.0646	4.158	15.5	0.240
20	0.086	5.544	11.6	0.180
30	0.129	8.316	7.74	0.120
50	0.215	13.86	4.64	0.072
100	0.431	27.72	2.32	0.036

The two parameters, annual PV damage and MTTF, are used for comparing the finial-added LPS with the PV-frame LPS. For LPS selection, it is reasonable to establish the following technical criteria:-

1. Accept Alternative if its average damage rate, N_{DB} < 1.0 per year
2. Accept Alternative if its MTTF > 1.0 year.

The finial-added alternative meets both technical criteria for power outputs up to 100 MW_{ac} but the PV-frame alternative could meet the technical criteria up to 3.6 MW_{ac} for a GFD = 30. Without finials added, the PV-frame alternative is cheaper. Hence, based on technical criteria, the PV-frame LPS could be selected for Solar PV farms of size 3.6 MW_{ac} and below. In regions

experiencing smaller GFDs, the acceptable size of the PV-frame LPS increases. For example, if the GFD = 10, then the maximum size of the PV-frame alternative may be 10 MW_{ac}.

6.0 LONG TERM OPERATION & MAINTENANCE IMPACT FROM LPS

Based on the results, an O&M impact study can be performed to address the number of occasions PV-module replacement have to be made over the service life of the plant. It is assumed that each replacement occasion will have at least one PV module replaced. Collateral damage may increase the number of PV modules in each occasion. With spare PV module stock, the mean-time-between-failure (MTBF) can be assumed to have a negligible replacement duration. It approximates the MTTF. Given the plant service life is L years, the number of occasions that PV modules need replacement from lightning damage is given by:-

$$\text{Integer } (L/\text{MTTF}) \tag{6}$$

Table 6 shows the long-term impact on operation and maintenance as measured by the number of occasions of PV module replacement.

Table 6: No. Of Replacements Over Service Life

Plant Size, MW _{ac} Output	No. of Replacement Occasions in 21 years	
	14mm Dia. Steel Finials	2 mm Aluminium Frame
1	0	5
2	0	11
5	0	29
10	0	58
15	1	87
20	1	116
30	2	175
50	5	291
100	9	583

For 21-years operation, large solar PV plants should not rely on the PV aluminium frame for lightning interception as they will require extensive replacement efforts. The provision of finials to the existing natural-component LPS improves the operation and maintenance situation tremendously by diverting the lightning strokes to them. If the average number of replacements is limited to say, once in 2 years, then a maximum of 10 replacements is allowed for a 21-year plant service life. In this case, the maximum acceptable plant size for the PV-frame LPS is less than 2 MW_{ac}. Thus, operation and maintenance requirements must be considered in the selection of LPS type. It may turn out that PV module replacement rate is the dominant and significant consideration in LPS selection for a PV farm.

With the estimated number of replacement occasions, a cost evaluation for the alternatives can be made. It then leads to the third selection criterion which is based on cost:-

3. Compare the total (additional capital cost, PV module replacement cost and loss of revenue from damages) costs and select the less costly alternative.

7.0 CONCLUSION

The solar PV farm lightning protection risk analysis can be updated with improved IE estimates. Progress in interception efficiency calculations points to a generally higher IE from finials than what is used in IEC 62305. Another critical factor that determines the performance of LPS is the sizing efficiency of the air termination. While the PV module aluminium frame may be used as a mesh-type air termination to save cost, caution is needed in their selection for operation in a high GFD region because its sizing efficiency is reduced by its thin aluminium thickness. This SE reduction is attributed to hot-spot melting of the metal at the point of lightning stroke attachment which results in damage to the PV contact surface at the frame's underside. An estimate of its damage rate has been demonstrated using the arc-root voltage drop model given in IEC 62305. It points to the importance of damage rate calculation and of bringing the calculated value into the lightning risk assessment routine.

Based on the estimates of IE and SE, the PV module's damage rate can be estimated. With them a comparative analysis can be made between the PV-frame LPS and the finial-added LPS. Preliminary results indicate that for solar PV farms exceeding a certain size and operating in the Malaysian climate, the finial-added air termination may be a cost-effective alternative. It also outperforms the PV-frame LPS by achieving a low damage rate and by meeting operation and maintenance requirements better. The technical performance and operation advantages may outweigh the additional construction cost for solar PV farms when their outputs exceed a certain size. This gives the PV Industry the opportunity to decide on the critical plant size after taking into consideration the cost criterion. ■

REFERENCES

- [1] IEC 62035 - Protection Against Lightning - Part 1: General Principles, 2010.
- [2] IEC 62035 - Protection Against Lightning - Part 2: Risk Management, 2010.
- [3] IEC 62035 - Protection Against Lightning - Part 3: Physical Damage to Structures and Life Hazard, 2010.
- [4] Alexander Kern, Christof Schelthoff, Moritz Mathieu, 'Calculation of interception efficiencies for air- terminations using a dynamic electro-geometrical model', Proc. of 11th International Symposium on Lightning Protection (SIPDA), Fortaleza (BR), pp. 44 – 49, Oct. 2011.
- [5] Alexander Kern, 'Simulation and measurement of melting effects on metal sheets caused by direct lightning strikes', International Aerospace and Ground Conference on Lightning and Static Electricity, Vol. 1, 1991.
- [6] L. Chemartin, P. Lalande, B. Peyrou, A. Chazottes, P.Q. Elias, C. Delalondre, B.G. Cheron, F. Lago, 'Direct Effects of Lightning on Aircraft Structure: Analysis of the Thermal, Electrical and Mechanical Constraints', Journal Aerospace Lab, Issue 5, Dec. 2012.
- [7] Yulia Kostogorova-Beller, Tianshi Lu, 'Numerical Modeling of Experimentally Obtained Lightning Arc Root Damage in Metal Sheets', International Journal of Engineering Practical Research (IJEPR) Vol.2 Issue 4, Nov. 2013.
- [8] Jindong Huo, JoAnne Ronzello, Alex Rontey, Yifei Wang, Linda Jacobs, Timothy Sommerer and Yang Cao, 'Development of an arc root model for studying the electrode vaporization and its influence on arc dynamics', AIP Advances 10, 2020.
- [9] EPRI AC Transmission Line Reference Book – 200kV and above, Chapter 6.2, 3rd Edition, 2005.
- [10] I. Naxakis, E. Prygioti, V. Perraki, E. Tselepis, 'Studying the effect of impulse voltage application on c-Si PV Modules', Solar Energy Vol.144, pp. 721-728, 2017.
- [11] CIGRE Working Group C4.407, Technical Brochure 549: 'Lightning Parameters for Engineering Applications', 2013.

PROFILES



THUM PENG CHEW graduated with the B. E. and the M. Eng. Sc. degrees from the University of Malaya. He is a Professional Engineer and a Fellow of IEM. He was a consultant specialised in electric power systems, lightning protection and earthing. He still has continuing interests in these areas. Email address: thumpc@gmail.com



SEAN LEE XI XIAN graduated with Bachelor of Electrical Engineering (Hons) from Multimedia University, Malaysia. He is a Professional Engineer registered with Board of Engineers Malaysia, Professional Technologist registered with Board of Technologist, Grid Connected PV (GCPV) Qualified Person registered with SEDA, Corporate Member of IEM and ASEAN Chartered Professional Engineer. He has extensive experience in substation primary detailed design and multi-disciplinary interfacing for MV, HV and EHV substation (up to 500kV). Apart from substation engineering work, he is also involved in renewable energy sector and energy storage system projects. Email address: xixianlee@hotmail.com