

EVALUATION OF RUTTING POTENTIAL OF HOT-MIX ASPHALT IN VARIABLE CONDITIONS

(Date received: 22.06.12 / Date accepted: 16.03.13)

Salman Ullah Sheikh¹, Nur Izzi Md. Yusoff², Mohd. Rosli Hainin³, Asmah Hamim⁴ and Che Ros Ismail⁵

^{1,3,5}Faculty of Civil Engineering, Universiti Teknologi Malaysia, 81310 UTM Skudai, Johor

^{2,4}Department of Civil and Structural Engineering, Faculty of Engineering and Built Environment
Universiti Kebangsaan Malaysia, 43600 UKM Bangi, Selangor

E-mail: ¹salman35@gmail.com, ²izzi@eng.ukm.my, ³roslihainin@gmail.com, ⁴asmahamim_84@yahoo.com, ⁵cheros@utm.my

ABSTRACT

Flexible pavements are designed to withstand structural and functional failures. Rutting or permanent deformation is a structural defect associated with functional implications that most common found in flexible pavement. It is mainly caused by wheel loads and accelerated by environmental factors. Although rutting is contributed to by all five layers in flexible pavement, the behaviour of the wearing course is the least understood and contributes significant effect on the overall performance of pavement. Therefore, this study was conducted to identify the rutting behaviour of the wearing course subjected to repetitive vehicle loading and exposed to different environments. This study was performed on a 22.6 m stretch of pavement consisting of two mixes, namely ACW14 and ACW20, and subjected to repetitive loading and exposure to various environmental effects such as wet stretches, heat conditions and spillage of petrol, diesel and cooking oil. For each test, a section of rut was measured every 50 cycles of the wheel track, which weighed 280 kg. A multivariate regression analysis was carried out to determine the relationship between rut depth and the number of wheel track passes. The results showed that exposure to petrol and diesel on pavement has a very detrimental effect as compared with other conditions.

Keywords: Hot-Mix Asphalt, Rutting, ACW14 and ACW20

1.0 INTRODUCTION

Rutting (or permanent deformation) has been identified by the Strategic Highway Research Program (SHRP) to be a major source of distress in hot-mix asphalt (HMA) pavements [1-2]. Rutting is load-related distress (caused by high axle loads and volumes) and is accelerated by material and environmental factors as well as by inadequate construction practices. A rut is the accumulation of plastic (permanent) deformation in the roadbed soil and in the base and sub-base layers as a result of compaction and/or consolidation under traffic loading. Rutting of the HMA layer may be caused by a combination of volume change and shear deformation resulting from traffic loads. In general, using good quality materials, coupled with adequate pavement design and construction practices can minimise the rut potential [3].

Rutting occurs as a combination of densification (volume change) and shear deformation. Many investigators have observed that the shear portion is more significant than the volumetric one. The major portion of permanent deformation occurs during initial loading [4]. The initially soft material is load-compacted and stiffened until the yield point is reached, whereupon additional plastic shearing accompanied by dilation (increase in volume due to the rearrangement of particles) occurs. Susceptibility to rutting depends on various factors. According to the SHRP, bitumen or binder (stiffness modulus, content) has approximately a 50% influence on rut size. An increase in binder

viscosity through the use of modified bitumens results in the decreased susceptibility of the HMA to rutting. Susceptibility also depends largely on the HMA structure. A mixture in which the grains are in contact with each other and form a contact structure is most resistant. A mineral mixture should consist of hard cubic-grained aggregate containing either a limited amount of natural sand or broken sand only [5]. Ruts occurring in the wearing course of HMA seem to cause a more serious problem [6].

A variety of laboratory test methods such as the French Rut Tester, the Georgia Loaded Wheel Tester (LWT), the Asphalt Pavement Analyzer (APA) and the Wheel Tracker Tester (WTT) have been developed to measure rutting potential of asphalt pavements [7]. Some methods have been used for many years, while others are still in the progress. One of the most common methods currently used is wheel tracking. Wheel-tracking devices subject asphalt pavement samples to repeated loadings by a moving wheel in order to estimate the anticipated permanent deformation characteristics of the pavement. More information regarding the specific relationships between mixture properties and rutting potential could benefit HMA designers greatly in choosing optimum mixture properties [8].

A laboratory study was conducted by Ahmad *et al.* [9] to evaluate the rut resistance of dense-graded HMA mixture using the Simple Performance test (SPT) dynamic modulus and WTT device. It was observed that a correlation was found between

the rut stiffness factor from SPT dynamic modulus test at 5 Hz loading frequencies with temperature at 40, 45 and 50°C and the rut depth from WTT test. Perraton *et al.* [10] used two types of WTT devices, namely “small” WTT and “large” WTT to investigate rutting on three different HMA layer systems used in Europe. Results show that the mean rate of rutting for “small” WTT devices is faster than for “large” WTT devices.

Muhaya and Thodesen [11] investigated how the specimen geometry affects the outcome of HMA rutting evaluations conducted by means of WTT device. One advantage of this test is specimen can be either from laboratory compacted specimen or extracted from pavements in the field. However, different results have been acquired between both types of specimen although similar mix designs. It may be due to differences in the confining pressure of the sample during WTT loading and differences in geometry of samples in that laboratory samples are rectangular while field samples are circular. The results indicated that the circular samples generally exhibit lower deformation than the square samples.

Depending on the magnitude of the traffic load and the relative strength of the pavement layers, rutting can occur in the subgrade, subbase, base, or upper asphalt (HMA) layers [12]. The National Center of Asphalt Technology (NCAT) conducted several studies and found that rutting generally occurs in the top 75 to 100 mm of HMA pavement [13]. For any flexible pavement section, its rut is typically determined by computing the mean rut depth (mean difference in elevation between the rutted wheel paths and the surrounding) of the pavement surface along the length of the project. Based on the mean rut depth, three severity levels can be defined, as shown in Table 1 [14].

Table 1: Severity levels of rut depth

Severity level	Mean rut depth
Low	6 to 12 mm (0.25 to 0.50 inch)
Medium	12 to 25 mm (0.5 to 1.0 inch)
High	More than 25 mm (1 inch)

Although rutting is contributed to by all five layers in flexible pavement, the behaviour of the wearing course is the least understood. Therefore, it is hypothesized that this layer, under various conditions, contributes a significant effect of the overall performance of pavement. This study was conducted to identify the rutting behaviour of the wearing course subjected to repetitive vehicle loading and exposed to different environments. The number of wheel passes and rut depth was correlated to derive a mathematical equation based on respective exposure conditions; subsequently, the future rut depth with respect to the number of wheel passes under variable exposure conditions can be determined. A multivariate regression analysis was carried out to determine the relationship between rut depth and the number of wheel track passes.

2.0 METHODOLOGY

The tests were conducted according to the required specification. Prior to these tests, a calibration process was carried out to obtain appropriate speed for the wheel track. A total of two design mixes, ACW14 and ACW20, were tested under 11 variable exposure conditions.

2.1 Calibration

To determine the rutting potential of HMA in variable conditions, calibration of the wheel track must be carried out first before any experimental work can start. The wheel track used in this study had a width of 919 mm and a total length of 22.6 m (Figures 1 and 2). Calibration work was performed to determine the speed for each dial number with variable imposed load. The imposed load implied varies from 80 kg (self-weight of the wheel) to 180 kg. From this calibration process, an appropriate speed was adopted to obtain the rutting potential of HMA in variable conditions.

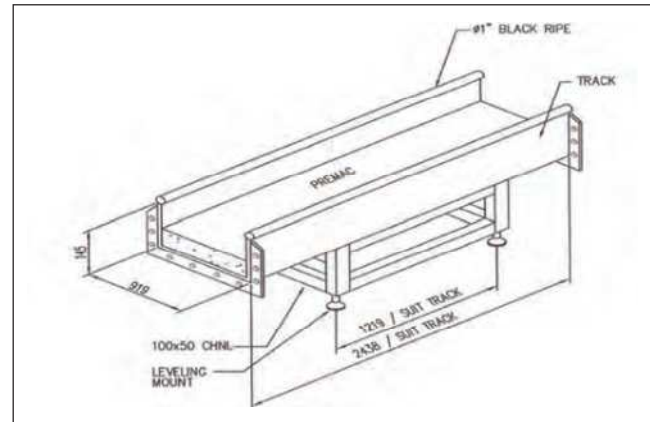

Figure 1: Isometric view of the wheel track

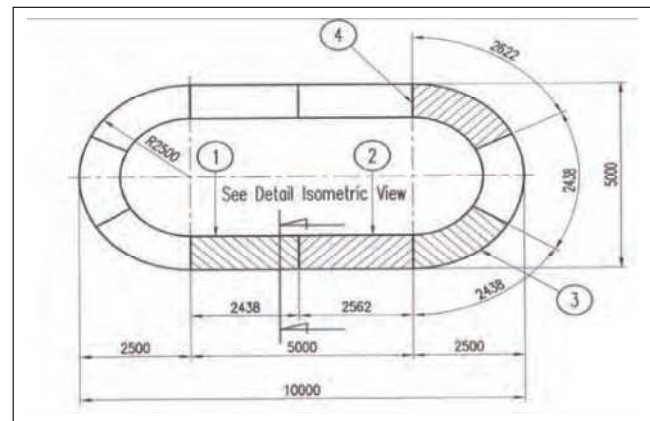

Figure 2: Plan view of the wheel track

2.2 Track Preparation

Two design mixes were used in this study, namely ACW14 and ACW20; 80% of the track was laid with ACW14 and 20% with ACW20. Prior to laying the premix, the entire track was grease-brushed so that the track could be easily cleaned after testing. It is worth noted that only HMA wearing course was used for testing and did not include other pavement layers (binder course, base, sub-base and subgrade). Markings were made on the entire track so that the premix could be laid uniformly. The uncompacted premix height was 60 mm on all straight stretches of the track, whereas the uncompacted premix height varied from 60-70 mm at the corners to take super elevation into consideration. The final thickness of the pavement was 50 mm on the straight stretches varied from 50-60 mm at the corners. ACW14 was obtained from the batching plant, whereas ACW20 was prepared in the laboratory. The premix laying was laid manually and a compactor machine was used to achieve proper compaction of the HMA.

2.3 Variable Environmental Exposure

To obtain rut equations for variable environmental exposure, the track was then sub-divided into the following regions: straight and corner stretches of ACW14; straight and corner stretches of ACW20; joint between ACW14 and ACW20 at straight and corner stretches; a straight stretch of ACW14 exposed to a temperature of 60°C; a straight stretch of ACW14 exposed to continuous wet conditions; a straight stretch of ACW14 with a spillage of one liter of petrol; a straight stretch of ACW14 with a spillage of one liter of diesel; and a straight stretch of ACW14 with a spillage of one liter of cooking oil. For each test, a section of rut was measured every 50 cycles of the wheel track, which weighed 280 kg. A total of 400 passes were made to obtain the desired results. These regions are shown in Figure 3. This study also concerned about the effect of environmental exposure to rutting performance on pavement.

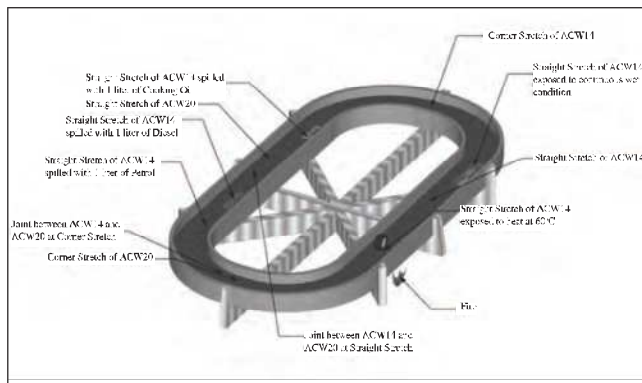

Figure 3: Different regions exposed to various environmental conditions

3.0 RESULTS AND DISCUSSION

Several tests were conducted to determine the rutting potential of HMA for two mixes, ACW14 and ACW20, in 11 variable environmental conditions. A total of 20 tests were conducted to obtain the rutting equations. Prior to these tests, the wheel track was calibrated to determine the appropriate speed to be used in the rutting tests.

3.1 Calibration Results

Calibration work was carried out to determine the speed for each dial number with a variable imposed load. The imposed load varied from 80 kg (self-weight of the wheel) to 180 kg. Five tests were conducted to determine the appropriate speed. The weights used in the calibration process were 80, 105, 130, 155 and 180 kg. Based on the calibration results in Figure 4, the dial gauge number 4 was used in the process of obtaining rut equations, because the velocity did not change significantly although the imposed load increased. Dial gauge 4 yielded a velocity of 6 km/hr, which was then adopted in the experiment.

3.2 Rutting Potential under Variable Environmental Exposure

The results of the rutting potential in variable environmental conditions are discussed in detail.

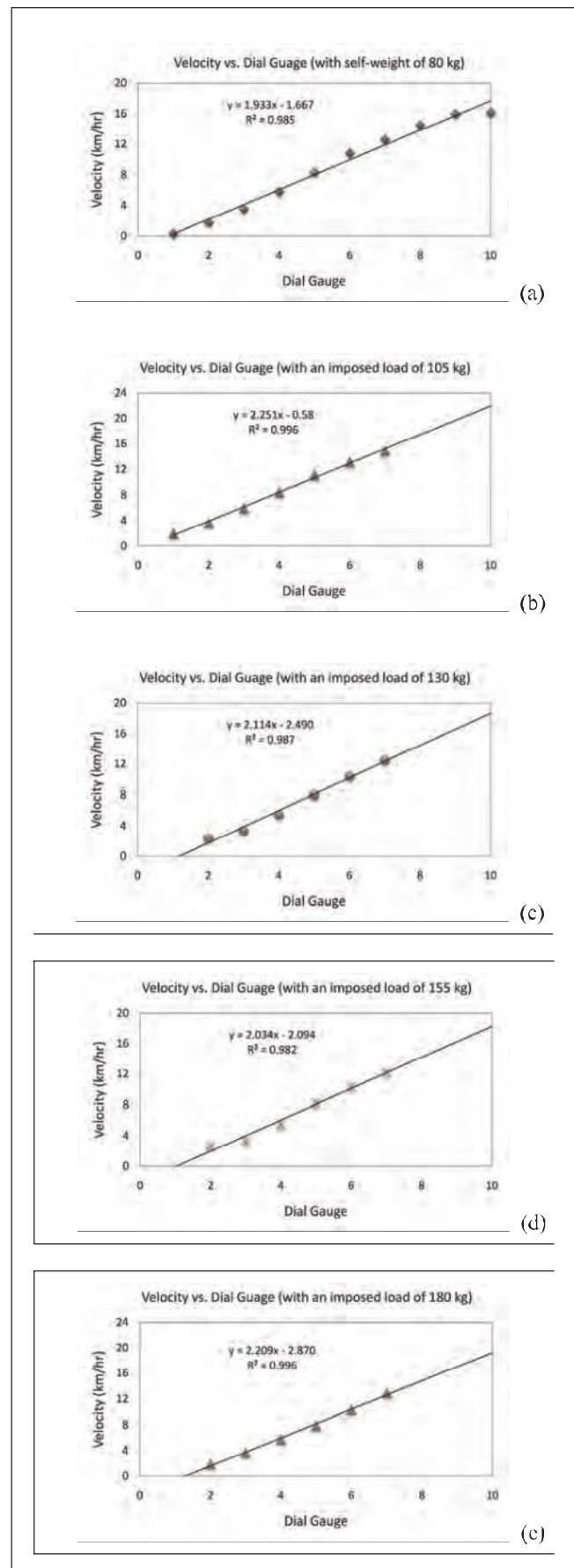

Figure 4: Velocity versus dial gauge with an imposed load of (a) 80 kg (b) 105 kg (c) 130 kg (d) 155 kg and (e) 180 kg

3.2.1 Straight and Corner Stretches of ACW14

The rutting process on the straight section of ACW14 appeared to be relatively slow. There was no obvious rutting after 400 cycles. Maximum rutting after 400 cycles was 1.62 mm. A quadratic relationship was obtained between the rut depth and the number of wheel track passes on ACW14 on the straight stretch, as shown in Figure 5.

$$y = 4 \times 10^{-6} x^2 + 0.0024x \quad (1)$$

where y is the rut depth and x is the number of wheel passes. The polynomial regression for Equation 1 is $R^2 = 0.974$.

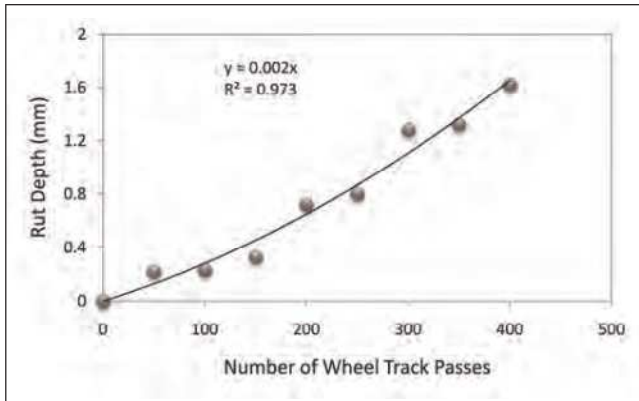

Figure 5: Rut depth versus number of wheel track passes on the straight stretch of ACW14

The rutting process on the corner section of ACW14 also appeared to be relatively slow. Rutting of more than 1 mm was observed after 300 wheel track passes. Rutting at the corner section was high due to the centrifugal force generated by the wheel as it cornered. Maximum rutting after 400 cycles was 1.60 mm.

A linear relationship was obtained between the rut depth and the number of wheel track passes on ACW14 at the corner stretch, as shown in Figure 6.

$$y = 0.006x \quad (2)$$

where the symbols are as previously defined. The linear regression for Equation 2 is $R^2 = 0.927$.

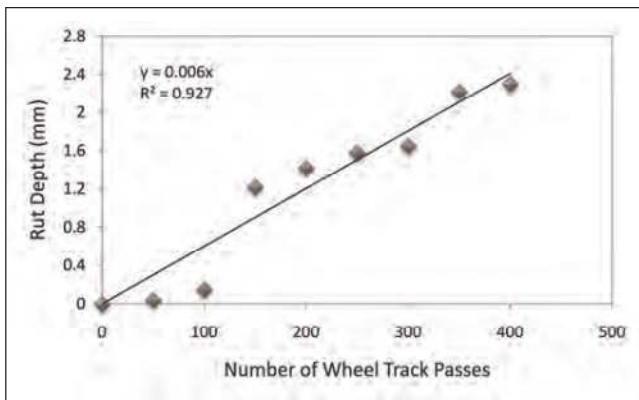

Figure 6: Rut depth versus number of wheel track passes on the corner stretch of ACW14

3.2.2 Straight and Corner Stretches of ACW20

The rutting process on the straight section of ACW20 appeared to be relatively fast. Rutting of more than 2.5 mm was observed after 50 wheel track passes. Rutting on the straight section of ACW20 was high due to the poor compaction caused by using the vibrating plate compactor¹. When the machine is used for compacting asphalt, one of the problems that might run into is sticking or adhesion of the asphalt material to the bottom of the plate. This can lead to poor compaction and subsequently accelerates the rutting deformation of HMA wearing course.

Maximum rutting after 400 cycles was 6.03 mm. This type of rutting is classified as low severity. It is found that the rutting process of the ACW20 occurs relatively faster compared to ACW14 which could be due to lower degree of compaction as mentioned earlier.

A cubic relationship was obtained between the rut depth and the number of wheel track passes on the straight stretch of ACW20.

$$y = 3 \times 10^{-7} x^3 + 0.053x \quad (3)$$

where the symbols are as previously defined. The polynomial regression for Equation 3 is $R^2 = 0.988$.

The rutting process at the corner section of ACW20 also appeared to be relatively fast. Rutting of more than 2.7 mm was observed after 50 wheel track passes. Rutting at the corner section of this mix was due mainly to the high centrifugal force generated by the wheel as it cornered and poor compaction using the vibrating plate compactor. Maximum rutting after 400 cycles was 40.4 mm. This type of rutting is classified as high severity.

A mathematical relationship was obtained between the rut depth and the number of wheel track passes at the corner stretch of ACW20.

$$y = 4 \times 10^{-7} x^3 + 0.078x \quad (4)$$

where the symbols are as previously defined. The polynomial regression for Equation 4 is $R^2 = 0.940$. Figures 7 and 8 show the curves for rut depth versus number of wheel track passes for the straight and corner stretches of ACW20 respectively.

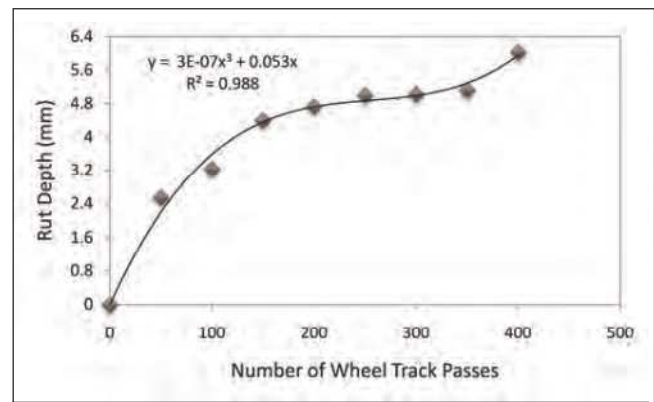

Figure 7: Rut depth versus number of wheel track passes on the straight stretch of ACW20

¹ This machine features a flat, broad plate mounted on the bottom of a motor and frame. The plate makes direct contact with the surface, and when the machine is activated, the plate will vibrate at a high rate of speed to create centrifugal force for compacting materials [15]. This vibratory action helps "settle" the new asphalt which will help it stay in place much longer instead of just tamping it in with a hand tamp [16].

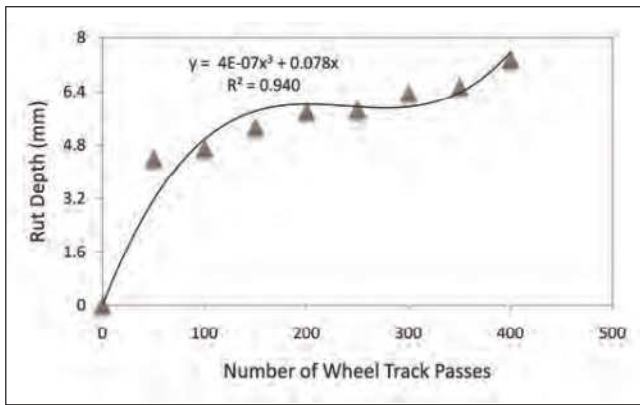

Figure 8: Rut depth versus number of wheel track passes on the corner stretch of ACW20

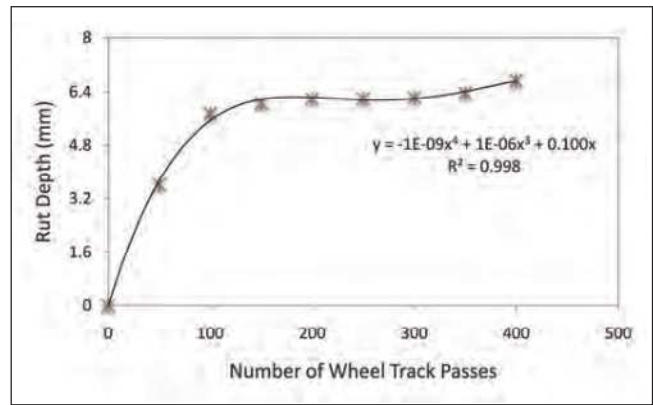

Figure 9: Rut depth versus number of wheel track passes at the joint between ACW14 and ACW20 on the straight stretch

3.2.3 Joint between ACW14 and ACW20 on the Straight Stretch

The rutting process at the joint between ACW14 and ACW20 on the straight stretch appeared to be relatively fast. Rutting of more than 5.11 mm was observed after 50 wheel track passes. Rutting at the joints between these two mixes was generally due to the time of laying the ACW20. Since the ACW20 was laid a week later than the ACW14 without applying a tack coat, there was no proper adhesion between the existing wearing surface and the new bituminous wearing surface. Rutting at the joint between these two mixes could be caused by lower density induced by the lower mix temperature during compaction resulting in low tensile strength. Field studies showed that typical density of the HMA near a joint is at least two to three percent lower than the remaining pavement resulted in low tensile strength, coupled with oxidative hardening of the asphalt due to high voids in the mixture in the joint area [13]. It was observed that there was poor adhesion between ACW14 and ACW20. In addition, poor adhesion between asphalt and the aggregate can aggravate the problem adjacent and cause more rapid deterioration. Another factor contributing to rutting at the joint between the two mixes is the improper compaction carried out using the vibrating plate compactor. Maximum rutting after 400 cycles was 78.4 mm. This type of rutting is classified as high severity.

A mathematical relationship was obtained between the rut depth and the number of wheel track passes at the joint between ACW14 and ACW20 on the straight stretch:

$$y = -1 \times 10^{-9}x^4 + 1 \times 10^{-6}x^3 + 0.100x \quad (5)$$

where the symbols are as previously defined. The polynomial regression for Equation 5 is $R^2 = 0.998$. Figure 9 shows the curve for rut depth versus number of wheel track passes for the joint between ACW14 and ACW20 on the straight stretch.

3.2.4 Joint between ACW 14 and ACW20 at the Corner Stretch

The rutting process at the joint between ACW14 and ACW20 at the corner stretch appeared to be relatively fast. Rutting of more than 3.13 mm was observed after 50 wheel track passes. Similar finding was observed as previously mentioned in Section 3.2.3 and therefore, is not discussed for brevity. Maximum rutting after 400 cycles was 44.0 mm. This type of rutting is classified as high severity. A mathematical relationship was obtained

between the rut depth and the number of wheel track passes at the joint between ACW14 and ACW20 on the corner stretch:

$$y = 3 \times 10^{-7}x^3 + 0.062x \quad (6)$$

where the symbols are as previously defined. The polynomial regression for Equation 6 is $R^2 = 0.983$. The curve for rut depth versus number of wheel track passes for the joint between ACW14 and ACW20 at the corner stretch is shown in Figure 10.

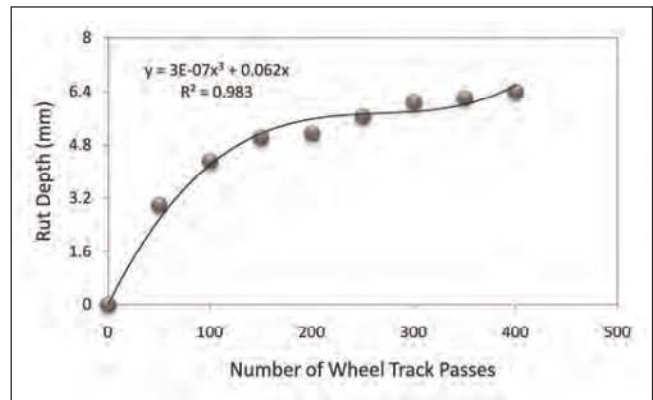

Figure 10: Rut depth versus number of wheel track passes at the joint between ACW14 and ACW20 at the corner stretch

3.2.5 Straight Stretch of ACW14 Exposed to a Temperature of 60°C

A quadratic relationship was obtained between the rut depth and the number of wheel track passes on a pavement exposed to a temperature of 60°C:

$$y = -4 \times 10^{-5}x^2 + 0.042x \quad (7)$$

where the symbols are as previously defined. The polynomial regression for Equation 7 is $R^2 = 0.924$. Meanwhile, Figure 11 shows the relationship between rut depth and number of wheel track passes on a pavement exposed to a temperature of 60°C.

To mimic the actual temperature experienced by a given pavement in practice, the test pavement section was heated to a temperature of 60°C. It was observed that the rutting process at this temperature was relatively fast. Rutting of 2.0 mm was observed after 50 wheel track passes. Since the softening point of binder is at 44°C and the pavement was tested at a temperature

of 60°C, bleeding and segregation took place. The imposed load applied on the pavement accelerated this bleeding and segregation and therefore led to rutting (Figure 12). Maximum rutting after 400 cycles was 10.4 mm. This type of rutting is classified as low severity.

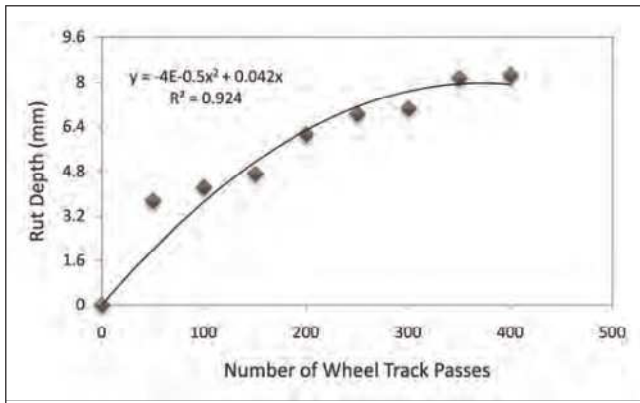

Figure 11: Rut depth versus number of wheel track passes on the straight stretch of ACW14 exposed to a temperature of 60°C

3.2.6 Straight Stretch of ACW14 Exposed to Continuous Wet Conditions

The rutting was tested on pavement exposed to continuous wet and water-ponding conditions. It was observed that the rutting process under this environmental exposure was relatively slow. Rutting of 0.68 mm was recorded after 50 wheel track passes. Rutting under this environmental condition is accelerated by the presence of an air void. Water seeps through these voids and causes a stripping process to occur. Poor compaction accelerates the rutting phenomenon. Water further loosens the bonding of aggregates, causing them to displace horizontally, and therefore causes rutting to occur under the wheel path (Figure 13). Maximum rutting after 400 cycles was 4.0 mm. A quadratic relationship was obtained between the rut depth and the number of wheel track passes on pavement exposed to wet conditions:

$$y = -1 \times 10^{-5}x^2 + 0.014x \quad (8)$$

where the symbols are as previously defined. The polynomial regression for Equation 8 is $R^2 = 0.957$. Figure 14 shows the relationship between rut depth versus number of wheel track passes for the straight stretch of ACW14 exposed to continuous wet conditions.

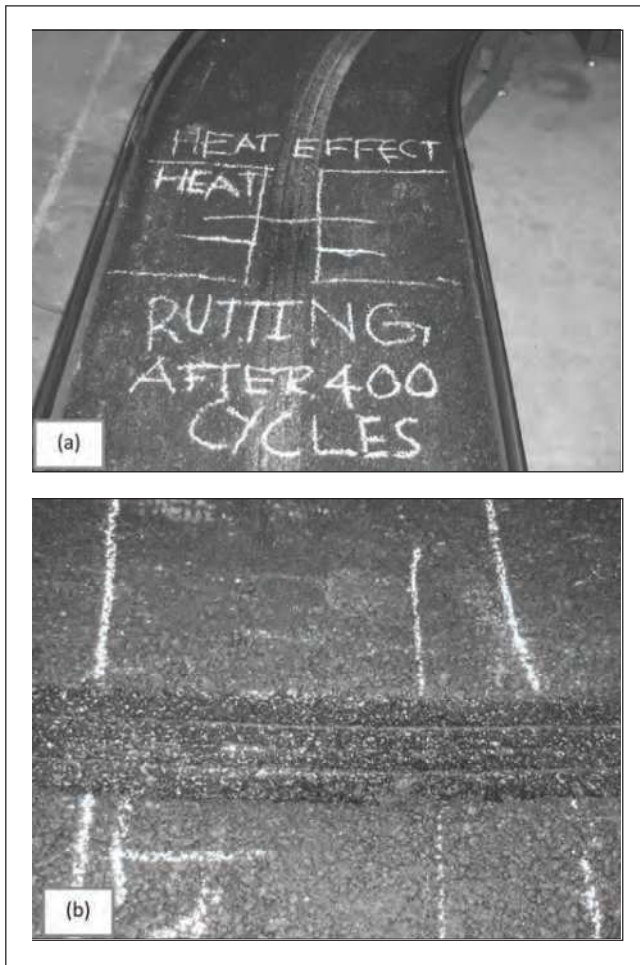

Figure 12: Bleeding and segregation of aggregates occurred after 400 cycles when ACW14 was subjected to a temperature of 60°C



Figure 13: Stripping of aggregates occurred after 400 cycles when ACW14 was exposed to continuous wet conditions

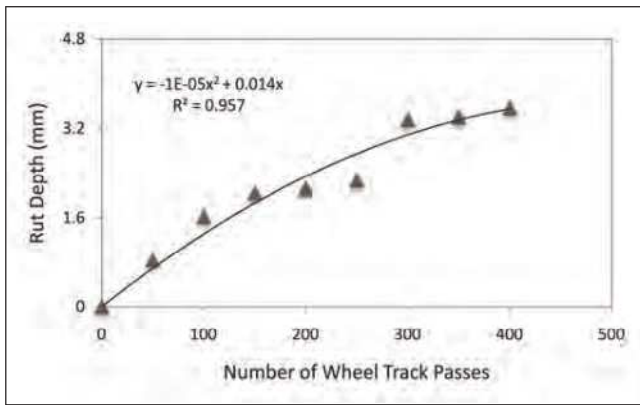

Figure 14: Rut depth versus number of wheel track passes on the straight stretch of ACW14 exposed to continuous wet conditions

3.2.7 Straight Stretch of ACW14 with a Spillage of One Liter of Petrol

The rutting process under exposure of petrol spillage was relatively very fast. Rutting of 37.27 mm was recorded after 50 wheel track passes. This type of rutting is classified as high severity. No further reading was taken because the pavement was severely damaged. The wheel track was slipped when passing through a section of pavement. Rutting at the petrol spillage area was very bad because petrol acts as a solvent and causes the asphalt to behave as “cutback asphalt”. When petrol is poured onto the pavement it actually dilutes the asphalt at room temperature and, in that particular moment, it becomes a liquid product. Hence, the pavement is not able to sustain the load because of losing the bonding between asphalt and aggregates. Therefore, lateral displacement occurs instantaneously when the load is applied, leading to severe rutting. This phenomenon is obvious in Figure 15 and no mathematical relationship was obtained because there was insufficient data.

3.2.8 Straight Stretch of ACW14 with a Spillage of One Liter of Diesel

The rutting process at the stretch exposed to diesel appeared to be relatively fast. Rutting of more than 4.45 mm was observed after 50 wheel track passes. The factors contributing to rutting at this location are similar to those for petrol. Diesel acts as “cutback asphalt” whereby it liquefies the asphalt at room temperature, which consequently loses its capacity to bond with the aggregates, leading to rutting. Maximum rutting after 400 cycles was 21.6 mm. This type of rutting is classified as moderate severity.

A mathematical relationship was obtained between the rut depth and the number of wheel track passes at the location exposed to diesel:

$$y = -1 \times 10^{-4}x^2 + 0.094x \quad (9)$$

where the symbols are as previously defined. The polynomial regression for Equation 9 is $R^2 = 0.993$. A relationship between rut depth and number of wheel track passes for the straight stretch of ACW14 with a spillage of one liter of diesel is depicted in Figure 16. Meanwhile, Figure 17 shows rut occurrence at ACW14 exposed to diesel after 400 cycles.

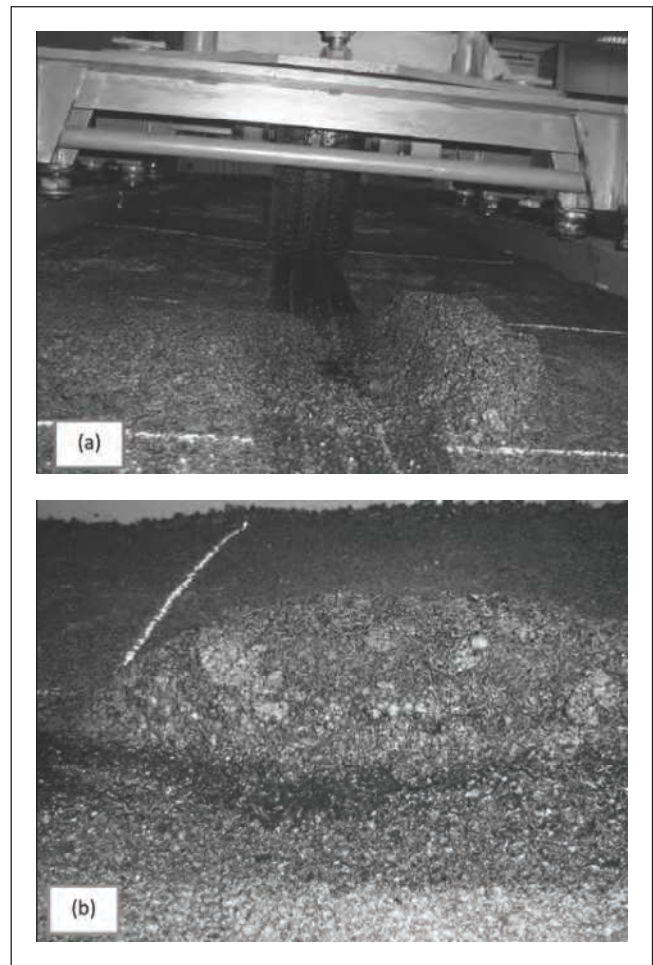

Figure 15: Severe rutting and discolouration occurred at the location where the pavement was exposed to petrol

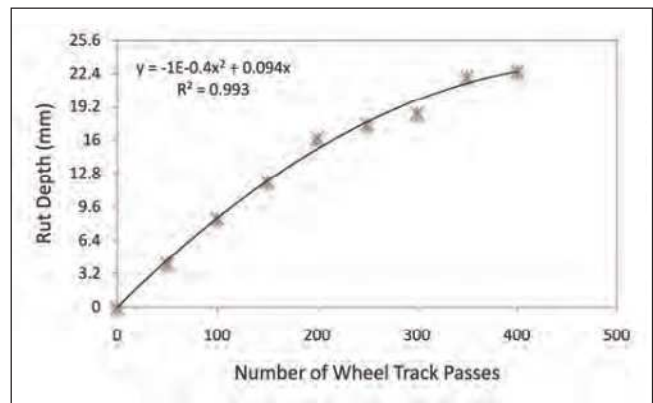

Figure 16: Rut depth versus number of wheel track passes on the straight stretch of ACW14 with diesel spillage

3.2.9 Straight Stretch of ACW14 with a Spillage of One Liter of Cooking Oil

According to the U.S. Environmental Protection Agency, approximately three billion gallons of waste cooking oil are collected annually from restaurants and fast food establishments in the United States [17]. Waste cooking oil can be polymerized to produce asphalt. A study was conducted by Wen *et al.* [18] to evaluate the laboratory performance of waste cooking oil-based



Figure 17: Rutting after 400 cycles at ACW14 exposed to diesel



Figure 18: Rutting after 400 cycles at ACW14 exposed to cooking oil

bioasphalt in HMA. Both binder and HMA performance tests were carried out by blending the bioasphalt with conventional asphalt. The results indicated that the addition of bioasphalt with traditional binder reduced the performance grade (PG)² of the base binder, indicating an increased resistance to thermal cracking, but reduced resistance to rutting. Based on the results obtained by Wen *et al.* [18], a spillage of cooking oil was used in this study to investigate its effect on the HMA wearing course.

The rutting process at the stretch exposed to cooking oil appeared to be relatively fast. Rutting of more than 4.1 mm was observed after 50 wheel track passes. The factors contributing to rutting at this location are the same to those for petrol and diesel. Cooking oil acts as “cutback” whereby it liquefies the asphalt at room temperature, causing the mix loses its strength and lead to rutting (Figure 18). Maximum rutting after 400 cycles was 58.0 mm. This type rutting is classified as high severity.

A mathematical relationship was obtained between the rut depth and the number of wheel track passes at the location exposed to cooking oil:

$$y = 4 \times 10^{-7}x^3 + 0.081x \quad (10)$$

where the symbols are as previously defined. The polynomial regression for Equation 10 is $R^2 = 0.978$. A relationship between rut depth and number of wheel track passes for the straight stretch of ACW14 with a spillage of one liter of cooking oil is depicted in Figure 19.

In summary, the most severe rutting effect was due to exposure to petrol and diesel. After 50 passes of the wheel track, rut depth was 37.27 mm and 4.45 mm for petrol and diesel respectively. The pavement exposed to petrol was severely degraded after 50 cycles; hence no further rut measurements could be taken. Under normal circumstances, surface rutting after 400 cycles is low (less than 5 mm) and is thus negligible. Any exposure to petroleum-based materials has a detrimental effect on the asphalt, as shown by the exposure to petrol, diesel and cooking oil. Exposure to

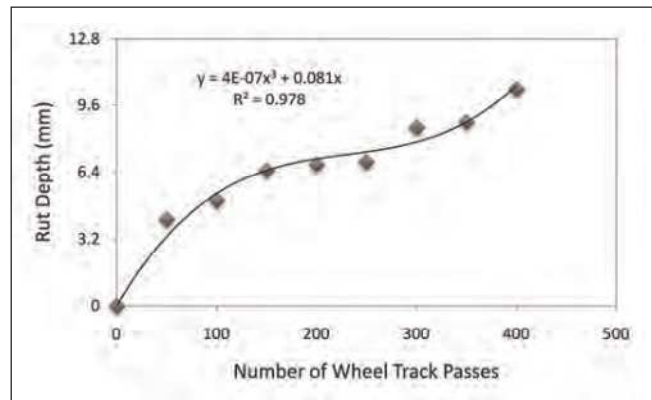

Figure 19: Rut depth versus number of wheel track passes on the straight stretch of ACW14 with cooking oil spillage

heat and wet conditions, on the other hand, does not severely damage the surface of the asphalt, and thus does not cause a high degree of rutting. However, long term exposure may increase the depth of the rut, although not to the extent caused by petrol or diesel.

4.0 CONCLUSION

Based on the results of this study, the most severe rutting effect is due to exposure to petrol and diesel. The pavement exposed to petrol was severely degraded; hence no further rut measurements were recorded. However, further rut depth was measured after 400 cycles for the pavement exposed to diesel and cooking oil were 22.6 mm and 58.0 mm respectively. Under normal circumstance, surface rutting after 400 cycles is low (less than 5 mm) and is thus negligible. Rutting of flexible pavement can be reduced by proper design of the HMA. Proper design of the mix increases bond between the aggregates, increasing the

² The performance grading (PG) system is based on climate, so the grade notation consists two portions: high and low pavement service temperature. The major concern for high temperature performance is rutting, which typically takes time to cumulate, therefore an average of 7 day maximum pavement temperature is used for describing the high temperature climate. On the low temperature side, thermal cracking can happen during one really cold night; therefore the minimum pavement temperature is used for describing the low temperature climate. For both high and low temperature grade, PG grades are graded in 6°C increment. The average 7 day maximum pavement temperature typically ranged from 46 to 82°C, and minimum pavement temperature typically ranged from -46 to -10°C [19].

shear strength of the asphalt-aggregate-filler matrix and reducing the occurrence of rutting. ACW14 and ACW20 mixes also exhibited different degrees of rutting under the same conditions. Finally, it was concluded that the WTT device is really useful in predicting the rutting performance of HMA pavement in variable conditions. It is recommended that this device to be used as a

standard performance test of HMA pavement by the Malaysian highway authorities as rutting is associated with hot in-service temperature. Results obtained from the WTT test can be used as a guideline for paving engineers to carry out rehabilitation and repair work in a more scheduled and systematic manner. ■

REFERENCES

- [1] McGennis, R.B., Anderson, R.M., Kennedy, T.W. and Solaimanian, M. (1995). Background of Superpave Asphalt Mixture Design and Analysis, FHWA-SA-95-003, Federal Highway Administration, Washington, D.C. 167 pgs.
- [2] Jackson, N.M. and Baldwin, C.D. (1999). Evaluation of the Asphalt Pavement Analyzer to Predict the Relative Rutting Susceptibility of HMA in Tennessee. International Conference on Accelerated Pavement Testing, Paper Number CS6-3.
- [3] Sheikh, S.U. (2007). Rutting Potential of Hot Mix Asphalt in Variable Conditions. MEng Dissertation, Universiti Teknologi Malaysia.
- [4] Kamran, M. and Measovic S. (1992). A Constitutive Model for Asphalt Concrete, Application to Rutting, Paper # 929386, 71st meeting Transport Research Board.
- [5] Radziszewski, P. (2007). Modified Hot mix asphalts Resistance to Permanent Deformations. Journal of Civil Engineering and Management. Vol. XIII, No 4, pp. 307-315.
- [6] Laurinavičius, A. and Oginskas, R. (2006). Experimental Research on the Development of Rutting in Asphalt Concrete Pavements Reinforced with Geo-synthetic Materials. Journal of Civil Engineering and Management. Vol. XII, No 4, pp. 311-317.
- [7] Collins, R., Watson, D.F. and Cambell, B. (1998). Investigation of the Asphalt Pavement Analyzer for Predicting Pavement Rutting. Research Report FL/DOT/SMO/98-427, Florida Department of Transportation.
- [8] Williams, S.G. (2003). The Effects of HMA Mixture Characteristics on Rutting Susceptibility. 2003 Annual Meeting of the Transportation Research Board, Washington.
- [9] Ahmad, J., Abdul Rahman, M.Y. and Hainin, M.R. (2011). Rutting Evaluation of Dense Graded Hot-Mix Asphalt Mixture. International Journal of Engineering & Technology. Vol. 11, No. 5, pp. 56-60.
- [10] Perraton, D., Di Benedetto, H., Sauzcat, C., De La Roche, C., Bankowski, W., Partl, M. and Grenfell, J. (2010). Rutting of Bituminous Mixtures: Wheel Tracking Tests Campaign Analysis. Journal Material and Structures. Vol. 44, pp. 969-989.
- [11] Muhaya, P.M. and Thodesen, C. (2012). Effect of Wheel Track Sample Geometry on Results. 7th RIIEM International Conference on Cracking in Pavements. Vol. 4, pp. 82-91.
- [12] Tarefder, R.A. and Zaman, M. (2002). Evaluation of Rutting Potential of Hot Mix Asphalt Using the Asphalt Pavement Analyzer, Final Report ORA 125-6660.
- [13] Roberts, F.L., Kandhal, P.S., Lee, D.Y. and Kennedy, T.W. (1996). Hot Mix Asphalt Materials, Mixture Design and Construction, 2nd Edition. NAPA Education Foundation, Lanham, Maryland.
- [14] American Association of State, Highway, and Transportation Officials. AASHTO (1986). Guide for Design of Pavement Structures. Washington, D. C.
- [15] WiseGeek (2012). What is a Vibrating Plate Compactor? <http://www.wisegeek.com/what-is-a-vibrating-plate-compactorm.htm> (accessed on 13 Dec. 2012).
- [16] Asphalt Sealcoating Direct (2012). Asphalt Plate Compactor <http://www.asphaltsealcoatingdirect.com/products/plate-compactorm> (accessed on 13 Dec. 2012).
- [17] U. S. Environmental Protection Agency. <http://www.epa.gov/region9/waste/biodiesel/questions.html> (assessed on 10 Dec. 2012).
- [18] Wen H., Bhusal, S. and Wen, B. (2012). Laboratory Evaluation of Waste Cooking Oil-Based Bioasphalt as Sustainable Binder for Hot-Mix Asphalt. Transportation Research Circular E-C165: Alternative Binders for Sustainable Asphalt Pavements, pp. 49-59.
- [19] Xie, B. (2013). Performance Grade System for Asphalt Binder. http://www.graniterock.com/technical_notes/performance_grade_for_asphalt_binder.html (assessed on 06 Feb. 2013).

PROFILES



SALMAN ULLAH SHEIKH is a professional engineer with Teguh Runding Sdn. Bhd, a Civil and Structural Consultant Firm based in Johor Bahru. He received his Bachelor of Engineering in Civil from Universiti Teknologi Malaysia. He also has double Masters in Structural Engineering and Highway and Transportation from Universiti Teknologi Malaysia, Skudai, Johor. He is Corporate Member of Institution of Engineers Malaysia (MIEM) and Registered Engineer with the Board of Engineers Malaysia (P.Eng (M)). He has published several conference publications over the years and more than 12 years working experience as a structural engineer.



NUR IZZI MD. YUSOFF is a lecturer in the Department of Civil and Structural Engineering, Universiti Kebangsaan Malaysia. He received his B.Sc. from Universiti Kebangsaan Malaysia, M.Eng. from Universiti Teknologi Malaysia and PhD from University of Nottingham, UK. His main research interest is pavement engineering and pavement materials, particularly on the rheological properties of bituminous materials.



MOHD. ROSLI HAININ is a Professor in the Faculty of Civil Engineering, Universiti Teknologi Malaysia. He is currently the Head of the Department of Geotechnics and Transportation of the faculty. He received his B.Sc. from Clemson University, USA, M. Sc. from University of Kansas, USA, and PhD from Auburn University, USA. His fields of interest are pavement materials, construction, design and rehabilitation. Dr Rosli is a member of the Association of Asphalt Paving Technologist (AAPT), USA and a technical committee of Pavement Engineering of Road Engineering Association of Malaysia (REAM). He has published more than 100 technical papers and supervised more than 50 post graduate students.



ASMAH HAMIM received her bachelor degree in Civil and Structural Engineering from Universiti Kebangsaan Malaysia in 2007. After graduated, she used to work with consultancy company for four years. Currently, she is in her final semester of Master of Civil and Structural Engineering, Universiti Kebangsaan Malaysia.



CHE ROS ISMAIL is a senior lecturer in civil engineering at Universiti Teknologi Malaysia. He obtained his B.Sc. (Civil Engineering) from University of Pacific, California in 1986 and M.Sc. (Transportation Eng.) from California State University, Sacramento in 1993. His research interest is in highway and traffic engineering related topics.