

CHAPTER 2

LITERATURE REVIEW

2.1 Introduction

Literature review is needed before any project is begun. The review will help to understanding the scope of the project and also the need to build the project. The review comes from the reading on the websites and also from the books. The information from the review will be used to start the project with an excellent idea. The review is also comes from the sample of the existing project in the websites.

2.2 Sample of Existing Project

2.2.1 Sample 1

Figure 2.1 shows the IR LED circuit. The oscillator will be used to generate a square wave at a desired frequency. The wave is fed into a transistor that drives an infrared LED on and off very rapidly. Because the emissions are infrared and very fast, neither is visible to the human eye.



Figure 2.1 : IR LED Circuit

Inexpensive infrared receiver chips are available at 36 kHz, 38 kHz, and 40 kHz. The receivers are sensitive to oscillations several kilohertz to either side, although reception distance improves with a better signal to start with. If used for object detection, the signal needs to travel the distance to the object, bounce off the object, and then travel the distance back to the receiver. So, distance becomes a factor.

Because infrared receivers amplify the signal to improve detection, electrical noise generated from the oscillator can leak into the receiver and trigger a false detection. This isn't a problem for VCRs or most consumer devices as they tend to contain either a transmitter (remote control) or a receiver (CD player), but not both.

Therefore, robot transmitter and receiver circuits must be carefully designed and positioned apart to be useful. Robots that chase electrical ghosts, spin in place, or jerk sporadically are initially amusing but eventually frustrating.

The lower the power of the circuit, the more likely it will be lower in noise. Also, liberal use of decoupling capacitors and metal shielding helps a lot. Greater distance between the circuits makes an enormous difference. [9]

2.2.2 Sample 2

For this project, an active infrared motion detector is constructed. Originally, both IR and an ultrasonic detector is want to build, but the problem is the ultrasonic detector would require too much time for a three week project.

However, building an IR motion detector would probably be a trivial exercise. So, to expand on the concept by building an ambient light ignoring motion detector.

This type of motion detector uses the same basic concept as the active infrared motion detector. An interruption in a 5 kHz modulated pulsating beam that is transmitted by an infrared diode and received by an infrared transistor sets off the alarm. A schematic of this motion detector is shown in Figure 2.2.

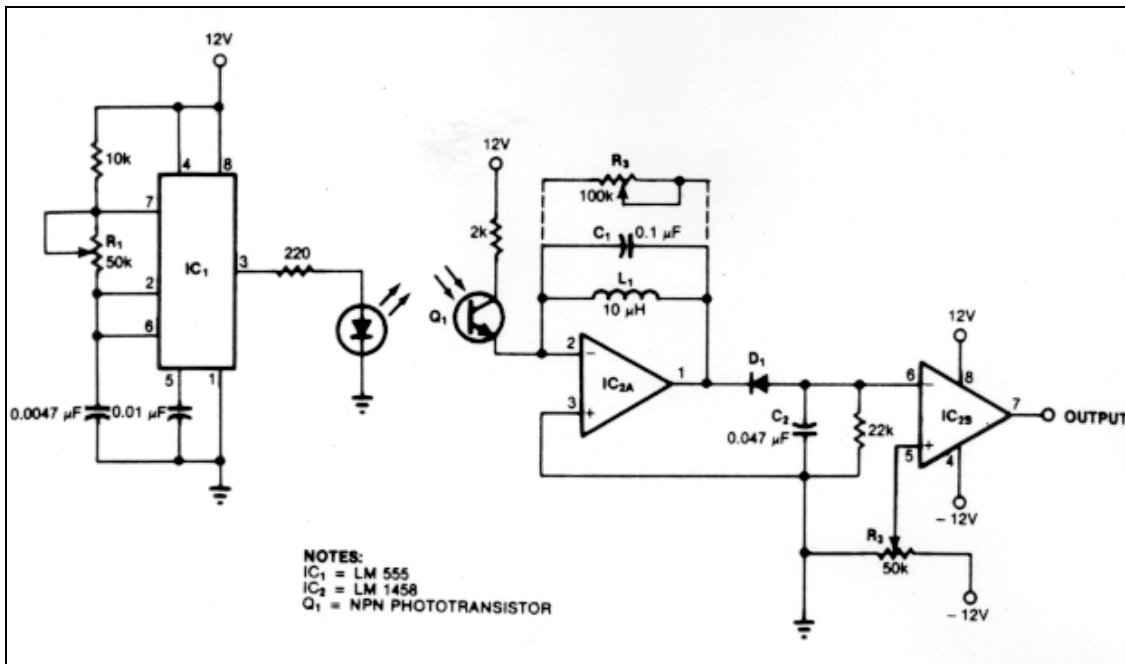

Figure 2.2 : Ambient-Light-Ignoring Active Motion Detector

The circuit on the left is the transmitter circuit that establishes a 5 kHz modulated infrared beam. As you can see from the schematic of the receiver circuit, a resonance-tuned narrowband amplifier reduces the detector's sensitivity to stray light. C1 and L1 in IC2A's feedback loop cause the op amp to pass only those frequencies at or near the LED's 5 kHz modulation rate. IC2B's output increases when the received signal is sufficient to drop the negative voltage across C2 below the reference set by R2. The output of this circuit is then attached to some load resistance, which can be an alarm LED. [10]

2.3 Technical Review

2.3.1 IR Motion Detector

A motion detector is a type of electronic security device that senses movement and usually triggers an alarm. Many types of motion detectors can sense motion in total darkness, without an intruder becoming aware that an alarm has been triggered. [11]

A motion sensor or movement detector is a device that senses movement to help raise the alarm if an intruder breaks into your home. This ability means that a motion sensor can play a key part in your home's security system. [12]

There are a multitude of sensors that become useful in industry settings, especially where factory operations are concerned. Different sensors include temperature sensors, optical sensors, pressure sensors, motion sensors, ultrasonic sensors, and more. Sensors allow for smooth operations and accurate measurement.[13]

Detector is an electronic circuit employing a transducer that sends an electronic indication of an event or condition to a security system control panel based on sensory input to its detection device from the premise. [14]

Ultrasonic motion detectors have certain advantages and disadvantages when compared with other types of motion detectors. The main advantages are that they are very sensitive and extremely fast acting. However, the largest problem with this type of motion detector is that it sometimes responds to normal environmental vibration that can be caused by a passing car or a plane overhead. Some types of motion detectors use infrared sensors to avoid this problem, but even these detectors have some problems. [15]

2.3.2 Parallel Port

Parallel port is a simple and inexpensive tool for building computer controlled devices and projects. The simplicity and ease of programming makes parallel port popular in electronics hobbyist world. The parallel port is often used in Computer controlled robots, Atmel/PIC programmers and home automation. [16]

PC parallel port can be very useful I/O channel for connecting your own circuits to PC. The PC's parallel port can be used to perform some very amusing hardware interfacing experiments. The port is very easy to use when you first understand some basic tricks. [17]

Table 2.1 : Parallel Port Pins Configuration

Port	Address (Decimal)	Address (Hex)
Data Line (8)	888	378H
Control Line (4)	890	37AH
Status Line (5)	889	379H

Table 2.1 shows the parallel port pins configuration. The parallel port consists three lines. There are data line, control line and status line. Data line has 8 pins and use as output port. Control line has 4 pins. The pins are bidirectional where it can be either input or output port. Status line has 5 pins and used for input port.

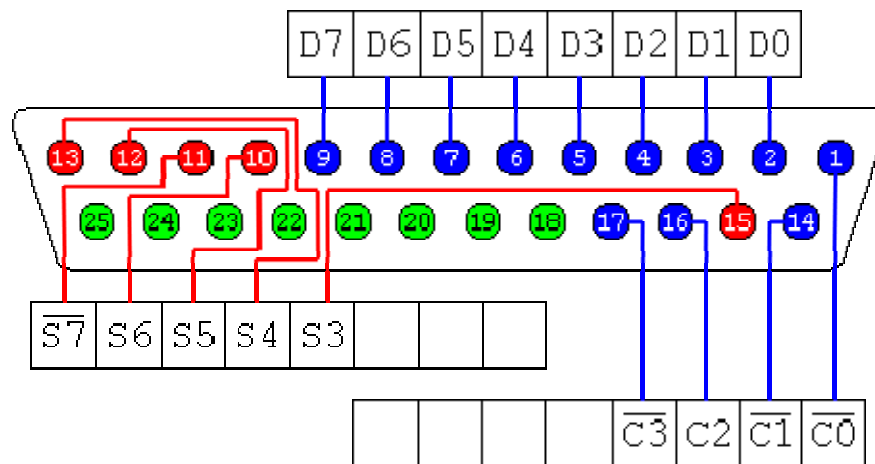

Figure 2.3 : Parallel Port Pin

Figure 2.3 shows the pin at the parallel port. Totally, number of pins is 25 pins. That is why parallel port is called DB25. Parallel port also have their ground pin. There are 8 ground pins at the parallel port.

2.3.3 Microsoft Visual Basic 6.0

Visual Basic is so popular mainly because all of its commands are easy to understand and follow. The language itself is similar to English unlike language such as C, which is arcane at most time. Data access features in VB tools allow you to create databases, front-end applications, and scalable server-side components for most popular database formats, including Microsoft SQL Server and other enterprise-level databases [2,18]

When writing programs with a user interface, the heart of the program will be the Visual Basic form. Adding visual controls and attaching programming code to them, you can quickly build powerful programs. Because the number of files in larger software development projects can be cumbersome, Visual Basic maintains a *Project File* (extension : *vbp*) to manage the forms, modules, and resource file used by your project. The Project Files contains no instructions of its own, but merely advises Visual Basic's built-in editor and compiler of the files that make up your project. [3]

2.3.4 Microsoft Access 2000

Microsoft Access 2000 is a powerful database management system (DBMS) that functions in the Windows environment and allows you to create and process data in a database.

The term *database* describes a collection of data organized in a manner that allows access, retrieval, and use of that data. A database management system, such as Access, allow to use a computer to create a database; add, change, and delete data in the database; sort the data in the database; retrieve data in the database; and create forms and reports using the data in the database.[1]

2.4 Summary

Based on the literature review, motion detector is the suitable method for this project. There are several type of motion detector; Microwave Motion Detector, Ultrasonic Motion Detector, Passive Infrared (PIR) Motion Detector and also Active Infrared Motion Detector.

Ultrasonic motion detectors have certain advantages and disadvantages when compared with other types of motion detectors. The main advantage is that they are very sensitive and extremely fast acting. However, the largest problem with this type of motion detector is that it sometimes responds to normal environmental vibration that can be caused by a passing car or a plane overhead. Some types of motion detectors use infrared sensors to avoid this problem, but even these detectors have some problems.

In passive infrared motion detectors, a sensor containing an infrared-sensitive phototransistor is placed in the area to be protected. Circuitry within the sensor detects the infrared radiation emitted by the intruder's body and triggers the alarm. The problem with using this type of detector is that it can be falsely triggered by warm air movement or other disturbances that can alter the infrared radiation levels in an area. In order to prevent this problem, newer systems use two infrared sensors which monitor different zones within a protected area. Logic within system triggers the alarm only when the two zones are activated in sequence, as would occur if a person walked through the protected area.

Figure 2.4 shows the operation of an active infrared motion detector. In the active system each sensor consists of two housings. One housing contains an infrared-emitting diode and an infrared-sensitive phototransistor. The other housing contains an infrared reflector. When positioned in front of an entrance to a protected area, the two housings establish an invisible beam. A person entering the area interrupts the beam causing an alarm to be triggered. An active motion detector is much more reliable than a passive one, but it

requires careful alignment when it is installed. The detector can be falsely triggered if one of the housings moves slightly and causes a discontinuous beam.

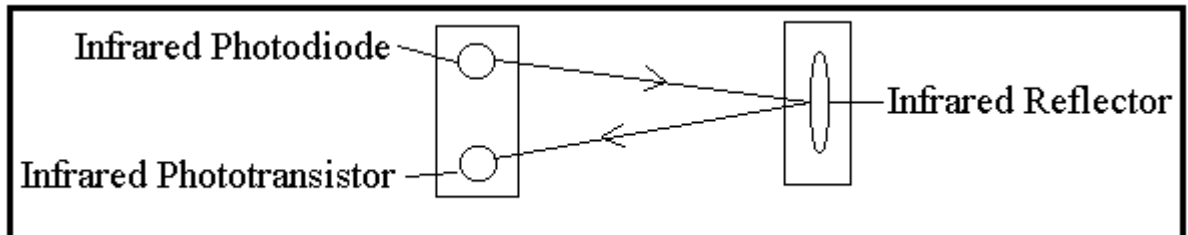

Figure 2.4 : Active Infrared Motion Detector